

# OPERATOR'S MANUAL

For Model 195 T Loader Attachment



## ⚠️ WARNING ⚠️

Read and become familiar with this manual **BEFORE** operating unit.

Before operating this equipment, thoroughly read this set of instructions, make sure you understand them, and only then follow the step-by-step directions. Failure to do so could result in serious property damage and / or serious bodily injury.

---

To our valued customer,

Thank you for choosing a **Telpro Inc.** product by **PARAGON PRO** Manufacturing Solutions. We are pleased that we are able to provide equipment to make your work easier.

Our efforts are focused on producing the finest quality equipment of which we are capable. We make sure to spend extra time and effort on our design and production in order to reduce your time and effort spent using the product.

We take pride in providing the best for our customers. Quality, innovation, and excellence are all qualities this company ensures. No product is sent without being factory tested and inspected to ensure the highest quality for you.

It all began in 1972 when Roland Young designed our first product, the PANEL-LIFT® Brand Drywall Lift, and revolutionized the drywall industry. To this day we are continuously making advancements in manufacturing and design.

Thank you again for giving us the opportunity to work with you. Any questions or comments that you have are always welcome.

**PARAGON PRO**  
MANUFACTURING SOLUTIONS

# CONTENTS

Warning/ Instructional Information .....	Page 1
Initial Assembly .....	Pages 2-3
Operation .....	Page 4
Parts Index .....	Page 5
Order Form .....	Page 6
Safety Information .....	Page 7
Warranty .....	Page 8

# **Warning**

**Read and follow these warnings and the instructions that follow. Failure to do so could result in serious property damage and/or serious bodily injury.**

• **BEFORE** operating this equipment, thoroughly read this set of instructions, make sure you understand them, and only then follow the step-by-step directions.

**FAILURE TO READ AND FOLLOW THESE INSTRUCTIONS** could result in failure of the equipment. Failure of the equipment while the lift is raised can include a sudden and rapid lowering of the lift and load possibly resulting in serious property damage and/or serious bodily injury.

- The PANELLIFT® Drywall Lift Loader Attachment is designed and intended for use **ONLY** in combination with PANELLIFT® brand drywall lifts, made by Telpro Inc. **DO NOT** use the loader attachment with any other type of lift. Failure to follow this warning may result in property damage and/or personal injury.
  - Use and maintenance of the PANELLIFT® Drywall Lift and loader shall be limited to authorized personnel who are trained in the proper techniques for its safe operation and maintenance and who are familiar with the various hazards of overhead material handling.
  - As with any lifting equipment, **ALWAYS WEAR A HARD HAT** when operating the PANELLIFT® Drywall Lift and keep children away from the work area. Failure to do so could result in serious bodily injury.
  - **DO NOT ATTEMPT TO USE YOUR PANELLIFT® Drywall Lift loader attachment IF ANY PART IS MISSING, DAMAGED OR WORN. ORDER A REPLACEMENT PART IMMEDIATELY.** Using a PANELLIFT® Drywall Lift loader attachment with missing, damaged or worn components can result in failure of the unit and possibly severe property damage and/or serious bodily injury.
  - **INSPECT THE CABLE BEFORE EACH USE. REPLACE AT THE FIRST SIGN OF**
- DAMAGE OR WEAR.** A worn, damaged or improperly installed cable can fail resulting in a sudden and rapid lowering of the lift and the load and possibly resulting in serious property damage and/or serious bodily injury.
- **The weight capacity of the PANELLIFT® Drywall Lift and loader attachment is 150 lbs. (68 kg). DO NOT load the unit beyond this limit. Load only one sheet of wallboard at a time.** Failure to follow this warning can result in an unstable load and/or damage to the PANELLIFT® Drywall Lift contributing to a sudden failure of the machine and serious property damage and/or serious bodily injury.
  - The PANELLIFT® Drywall Lift and loader attachment are designed exclusively as a material lift and shall be used for no other purpose. The PANELLIFT® Drywall Lift and loader attachment is not a personnel lift or platform and shall not be used as such. Using the PANELLIFT® Drywall Lift for purposes other than a material lift can subject the unit to stresses and loads that it was not designed to carry. This can result in failure of the unit which may include a sudden and rapid lowering of the lift and the load possibly resulting in serious property damage and/or serious bodily injury.
  - The PANELLIFT® Drywall Lift and loader attachment are made of steel which conducts electricity. **KEEP THE UNIT AWAY FROM LIVE ELECTRICAL WIRES.** Failure to do so could result in electrocution.
  - The Panellift® Model 195 Loader **WILL NOT** work with models 154-00 or 186-00 extensions installed.
  - Use only factory authorized replacement parts. Installation of other parts can compromise the safe design of the PANELLIFT® Drywall Lift loader attachment and may cause failure of the unit possibly resulting in serious property damage and/or serious bodily injury.
  - Operate only on hard, level surface at room temperature in a dry environment.

**Questions? - Call Paragon Pro Manufacturing Solutions Customer Service at:**

# INITIAL ASSEMBLY

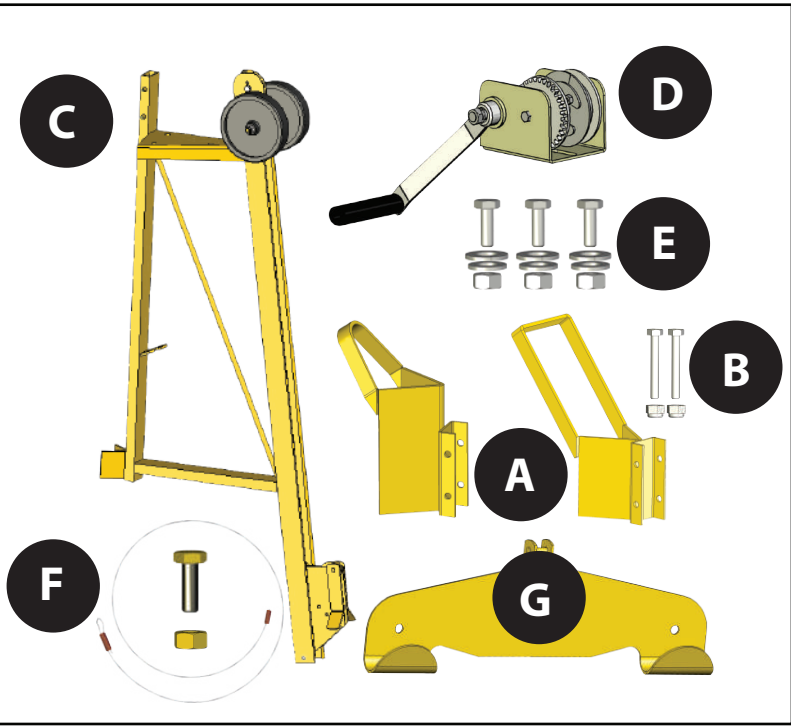

1. Unpack contents and ensure that you have these items:

- A. Two Mount Brackets**
- B. 1/4" X 2 1/4" bolts w/ nuts (2)**
- C. Frame Assembly w/ guide wheels & roller pocket**
- D. Winch**
- E 3/8" x 1" bolts w/ flat washers, lock washers and nuts (3)**
- F. Cable w/ 1/4" x 1" bolt and nut**
- G. Foot Bracket**

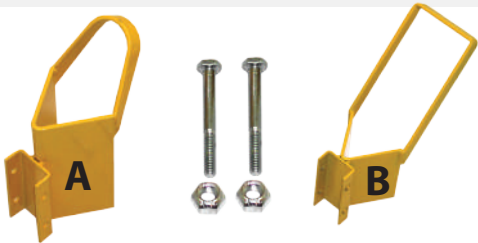

2. Select the correct mount bracket that corresponds to the model of the PANELLIFT® drywall lift you are using:
- Bracket "A" is for use with PANELLIFT® drywall lift models 138-2 and 125.
  - Bracket "B" is for use with PANELLIFT® drywall lift models 439 and 460.

If you are in doubt as to which model of PANELLIFT® drywall lift you are using call us at Paragon Pro and we'll help you identify it.

**(800) 448-0822 or (701) 775-0551**

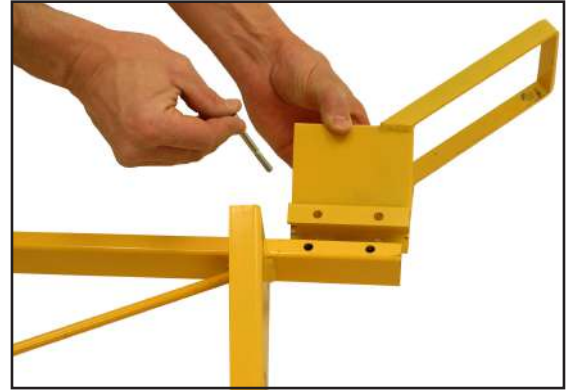

3. Attach the bracket to the loader frame using the 1/4" x 2 1/4" bolts and lock nuts.



4. Hang the loader on the PANELLIFT® drywall lift frame.



5. Attach the winch to the loader frame using the 3/8" x 1" bolts with fasteners. NOTE: Install the bolts with flat washers from the top down through the winch and fasten the lock washers and nuts from underneath the winch mount plate.

# INITIAL ASSEMBLY Cont.

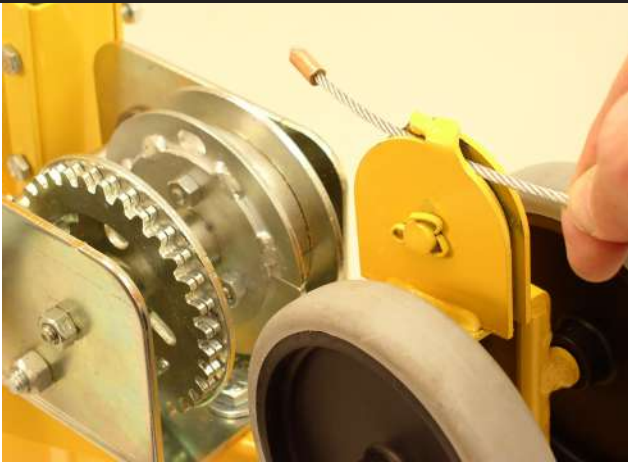

6. Pass the crimped end of the cable over the sheave pocket as shown



9. Rotate the winch handle clockwise to take up the slack in the cable around the winch drum.



7. Insert the crimped end of the cable through the oblong hole in the winch flange and behind the mooring tab as shown.



10. Push back on the foot bracket latch, insert bracket, and release latch.



8. Pull the stack out of the cable to seat the crimped end securely behind the mooring tab as shown.



11. Insert the cradle on the PANELLIFT® Drywall Lift and you're ready to lift drywall from floor to ceiling.

# OPERATION



1. To load, lift board by one end and place in the foot bracket making sure it is centered on the bracket.



2. Raise the board by rotating the winch handle.



3. When the board is fully raised, swing the cross arm support hooks under the board.



4. Raise the board off the loader foot bracket by rotating the PANELLIFT® Drywall Lift winch slightly and tilt the board horizontal.



5. Install the board as normal using your PANELLIFT® Drywall Lift.

# PARTS INDEX LOADER ATTACHMENT 195 T

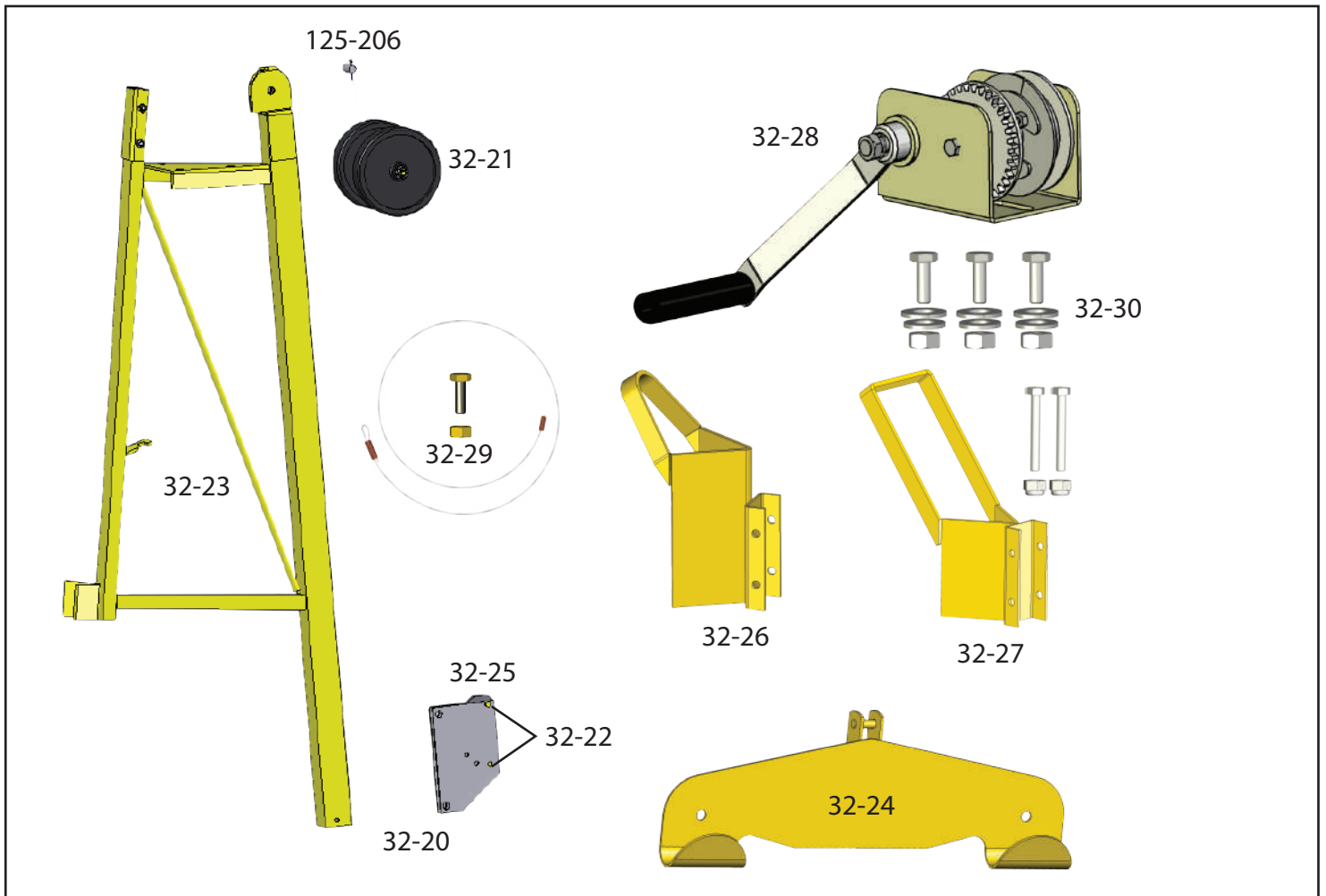

## PARTS LIST:

<u>Part#</u>	<u>Description</u>
125-206	Cable Sheave w/ Axle & Pins
32-20	Stop Bolt w/ Fasteners
32-21	Guide Wheel w/ Fasteners
32-22	Lift Bracket Rollers
32-23	Welded Frame
32-24	Foot Bracket
32-25	Roller Pocket
32-26	Mount Bracket w/ Fasteners 138-2/125
32-27	Mount Bracket w/ Fasteners 439/460
32-28	Loader Winch w/ Fasteners
32-29	Cable 54"
32-30	Winch Fasteners (3 nuts, bolts, washers)

# ORDER FORM

**COPY THIS ORDER FORM TO PLACE ORDERS PHONE**

**1-800-448-0822 FAX 1-800-474-9993**

**E-MAIL [sales@paragonpromfg.com](mailto:sales@paragonpromfg.com)**

Quantity	Part #	Description	Price Each	Total Price

**MAIL ORDER TO:**



**ATTN: Sales Dept. 7251 South  
42nd St. Grand Forks, ND  
58201  
[www.paragonpromfg.com](http://www.paragonpromfg.com)**

Sub Total

Shipping

Total

- VISA
- MC
- DISCOVER
- AM EX

CARD#

--	--	--	--	--	--	--	--	--	--	--	--	--	--	--

EXP. DATE

--	--	--	--

\*CVV2 #

--	--	--	--

- CHECK
- MONEY ORDER

SIGNATURE (required for credit card purchases)

\_\_\_\_\_  
Ship to Name (Please print clearly)

\_\_\_\_\_  
Address

\_\_\_\_\_  
City State Zip Code

\_\_\_\_\_  
Phone #

**Shipping address must be the same as billing address**

\*CVV2 is an authentication process established by credit card companies to reduce fraud for internet transactions. It consists of requiring a card holder to enter the CVV2 number in at transaction time to verify the card is on hand. For VISA, MASTERCARD, or DISCOVER, the 3 digit number is found on the back of the card. This number is printed on the signature area (last 3 digits after the card number). For AMERICAN EXPRESS cards, the 4 digit number is printed above to the right of the imprinted credit card number on the front of the card. Please call Telpro at 1.800.448.0822 if you have questions.

# SAFETY INFORMATION

**This product contains trace amounts of the following items which are known to cause.**  
These chemicals are not hazardous under product's intended use.  
Please review CAS# for more information.

<b>Chemical</b>	<b>Hazard</b>	<b>CAS#</b>	<b>% By Weight</b>
Arsenic	Cancer	7440-38-2	Trace
Cadmium	Developmental	7440-43-9	Trace
Chromium	Cancer, Developmental	7440-47-3	Trace
Ethylbenzene	Cancer	100-41-4	Trace
Lead	Cancer	7439-92-1	Trace
Methanol	Developmental	67-56-1	Trace
Methylene Chloride (Dichloromethane)	Cancer	75-09-2	Trace
Nickel	Cancer	7440-02-0	Trace
Propylene glycol monobutyl ether	Cancer	5131-66-8	Trace
Toluene	Developmental	108-88-3	Trace
Carbon Black	Cancer	1333-86-4	Trace

# WARRANTY

PARAGON PRO MANUFACTURING SOLUTIONS INC  
LIMITED WARRANTY

TELPRO INC products manufactured by PARAGON PRO MANUFACTURING SOLUTIONS INC are warranted to be free from defects in material and workmanship under normal use for one year from date of purchase.

NOTE: The following components of the PANELLIFT® Model 439 Drywall Lift are warranted to be free from defects in material and workmanship under normal use for three years from date of purchase.

Part#	Description		
52-03	#35 chain assembly	52-05	#40 chain assembly
52-07	#50 chain assembly	52-09	1 1/4" #50 roller assembly
52-10	#Outer planet set w/ bronze	52-11	Drive assembly
52-11	#1/2" x 2 1/4" Shoulder bolt w/ fastners	52-15	Clutch assembly w/sprocket
52-16	#40 Winch drive chain		

If a TELPRO INC product is proven to be defective in material or workmanship within the covered time frame from the date of purchase, return the defective part to PARAGON PRO MANUFACTURING SOLUTIONS INC and we will either repair or replace the part at our option. We will neither assume nor authorize any other person to assume for us any other liability.

Written notice including commercial invoice detailing the nature of the defect, date of purchase, and the company from which you purchased your unit must be received and acknowledged by PARAGON PRO MANUFACTURING SOLUTIONS INC before any units may be returned. Shipping costs shall be the responsibility of the product purchaser.

This warranty shall not apply to any equipment that has been repaired or altered outside of the factory in any way so as in our judgment to affect its stability or reliability nor which has been subjected to abuse, misuse, or negligence.

PARAGON PRO MANUFACTURING SOLUTIONS INC reserves the right to make changes or improvements in design without incurring obligation to install the same on previous units.

PARAGON PRO MANUFACTURING SOLUTIONS INC shall not be liable for loss, damage, or expense directly or indirectly from use of its products, their transportation, their repair, or from any other cause. Acceptance of the manufacturer's product constitutes agreement to the terms of this warranty and further that the manufacturer shall have no liability for any special or consequential damages.

This Warranty is in lieu of all warranties express or implied.

Fill in the following information, attach a copy of your sales receipt or invoice and file in a safe place.

Date of purchase: \_\_\_\_\_/\_\_\_\_\_/\_\_\_\_\_

Name & model# \_\_\_\_\_

Serial #: \_\_\_\_\_



**Questions about assembly?**

**Can't find a part?**

**Need some other help?**

**Call us: PARAGON PRO**  
MANUFACTURING SOLUTIONS

**1.800.448.0822**

**701.775.0551**

**We'll get you set up!**