

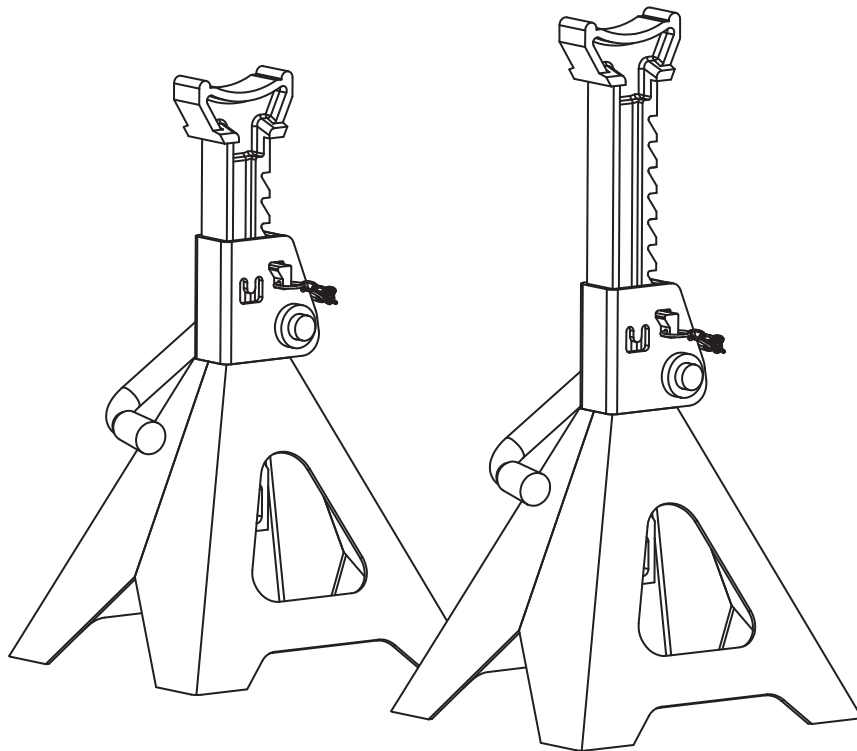

## **6-TON DOUBLE LOCKING JACK STANDS**

### **OWNER'S MANUAL**



#### **WARNING:**

Read carefully and understand all **ASSEMBLY AND OPERATION INSTRUCTIONS** before operating. Failure to follow the safety rules and other basic safety precautions may result in serious personal injury.

**Item# 107867**

Thank you very much for choosing a Strongway product! For future reference, please complete the owner's record below:

Model: \_\_\_\_\_ Purchase Date: \_\_\_\_\_

Save the receipt, warranty and these instructions. It is important that you read the entire manual to become familiar with this product before you begin using it.

This jack stand is designed for certain applications only. The distributor cannot be responsible for issues arising from modification. We strongly recommend this jack stand not be modified and/or used for any application other than that for which it was designed. If you have any questions relative to a particular application, DO NOT use the machine until you have first contacted the distributor to determine if it can or should be performed on the product.

For technical questions please call **1-800-222-5381**.

## INTENDED USE

Jack Stands are designed to support rated capacity, partial vehicle loads consisting of one end of a vehicle. Use both stands for each operation.

## TECHNICAL SPECIFICATIONS

	Description
Item	107867
Capacity	6 Tons
Lifting Range	15-1/2 inch – 23-3/8 inch

## GENERAL SAFETY RULES



**WARNING:** Read and understand all instructions. Failure to follow all instructions listed below may result in serious injury.



**CAUTION:** Do not allow persons to operate or assemble these jack stands until they have read this manual and have developed a thorough understanding of how the jack stands work.



**WARNING:** The warnings, cautions, and instructions discussed in this instruction manual cannot cover all possible conditions or situations that could occur. It must be understood by the operator that common sense and caution are factors that cannot be built into this product, but must be supplied by the operator.

## SAVE THESE INSTRUCTIONS

## JACK STANDS USE AND CARE

- **Do not modify the jack stands in any way.** Unauthorized modification may impair the function and/or safety and could affect the life of the equipment. There are specific applications for which the **jack stands** were designed.
- **Always check of damaged or worn out parts before using the jack stands.** Broken parts will affect the **jack stands** operation. Replace or repair damaged or worn parts immediately.
- **Store idle jack stands.** When **jack stands** are not in use, store them in a secure place out of the reach of children. Inspect it for good working condition prior to storage and before re-use.
- **Not for use by children** or people with reduced mental capacity.
- **Do not use** under the influence of drugs or alcohol.
- **Ensure children and other bystanders** are kept at a safe distance when using jack stands.



**WARNING! NEVER** use automotive jack stands to support both ends, or one side of a vehicle! Use only 1 pair per vehicle. Rated capacity is per pair only!



### **WARNING!**

1. Study, understand, and follow all instructions before operating this device.
2. Do not exceed rated capacity.
3. Use only on hard, level surfaces.
4. Center load on saddle.
5. Use as a matched pair only.
6. Stands are not to be used to simultaneously support both ends of a vehicle.
7. No alterations shall be made to this product.
8. Support only on areas of the vehicle as specified by the vehicle manufacturer.
9. Only attachments and/or adapters supplied by the manufacturer shall be used.
10. Use wheel chocks or other blocking device on opposing wheels before using jack stands.
11. Do not use jack stands for any use other than the manufacturer specified usage.
12. Do not use if damaged in any way.
13. Failure to heed these markings may result in personal injury and/or property damage.

Be sure all tools and personnel are clear before lowering load. Use only attachments and/or adapters supplied by the manufacturer. Lift only on areas of the vehicle as specified by the vehicle manufacturer.

## INSPECTION

- Inspect the Jack Stands before each use. Do not use if components are bent, broken or cracked.
- Inspect work area before each use. Make sure it is free and clear of any potential hazards.

## ASSEMBLY INSTRUCTIONS

1. Install ratchet bar into frame (fig.1) with ratchet portion of bar aligned with locking pawl (stopper).
2. Move the ratchet bar to its lowest position by raising the locking handle, thereby releasing the stopper, and guiding the bar downward (fig. 2).
3. Bend metal tab in (Fig. 3) using a hammer and punch.
4. This will help prevent inadvertent separation of the ratchet bar from base frame.

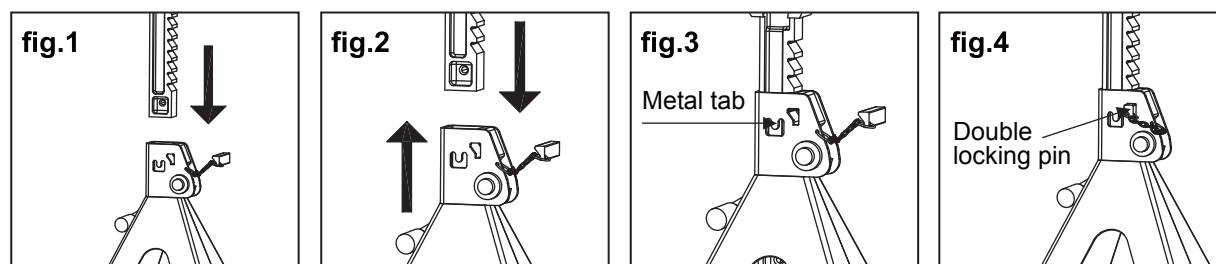

## OPERATING INSTRUCTIONS

1. Adjust height by pulling up on ratchet bar.
2. The weight of the locking handle should secure the ratchet bar in desired position. To confirm this, simply push down on the locking handle. Check to ensure ratchet is secure before loading.
3. Carefully position jack stands so that load is centered on stand's saddle.
4. **Slowly** lower the vehicle onto the stands.
5. Check to ensure vehicle is secure before working on, around or under. When used to support vehicle, use wheel chocks on all unlifted wheels in both directions to prevent inadvertent movement.

### TO LOWER LOAD

1. Ensure that all tools, equipment and personnel are clear before lowering load.
2. With suitable jack, raise vehicle clear of stands.
3. Carefully release stopper and allow ratchet to glide down to lowest position.
4. Carefully remove stands, then carefully lower vehicle with lift device.

## MAINTENANCE

- **Maintain your jack stands.** It is recommended that the general condition of any **jack stands** be examined before they are used. Keep your **jack stands** in good repair by adopting a program of conscientious repair and maintenance. Have necessary repairs made by qualified service personnel.
- **Periodically inspect each stand.** Ensure all parts move freely. Do not apply oil or grease to any portion of this product. If rust appears, sand affected area and cover with suitable utility paint. Please note that there are no replacement parts applicable to this device.

## STORAGE

Store stands in upright position and in a clean, dry area.

## ASSEMBLY DIAGRAM AND PARTS LIST

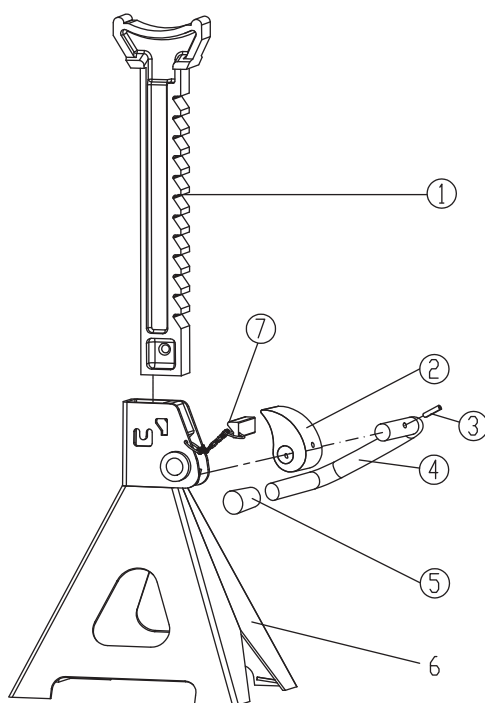

Item	Part#	Description	Qty
1	T46002C-I-2	Ratchet bar	1
2	T46001-I-4	Locking pawl	1
3	GB879	Spring pin D4x30	1
4	T46001-I-6	Locking handle	1
5	T412002-6	Handle sleeve	1
6		Base frame	1
7	T46002C-I-3 (ASM)	Safety pin assembly	1

Safe Operating Temperature is between 40°F – 105°F (4°C - 41°C)

## REPLACEMENT PARTS

For replacement parts Customer Service at **1-800-222-5381**. Not all equipment components are available for replacement; illustrations provided are a convenient reference of location and position in the assembly sequence. When ordering parts the following will be required: Model Number, Serial Number and Description.

**The distributor reserves the rights to make design changes and or improvements to product lines and manuals without notice.**

For replacement parts and technical questions, please call 1-800-222-5381.

## **Limited Warranty**

### **Limited Warranty**

Northern Tool and Equipment Company, Inc. ("We" or "Us") warrants to the original purchaser only ("You" or "Your") that the Strongway product purchased will be free from material defects in both materials and workmanship, normal wear and tear excepted, for a period of one year from date of purchase. The foregoing warranty is valid only if the installation and use of the product is strictly in accordance with product instructions. There are no other warranties, express or implied, including the warranty of merchantability or fitness for a particular purpose. If the product does not comply with this limited warranty, Your sole and exclusive remedy is that We will, at our sole option and within a commercially reasonable time, either replace the product without charge to You or refund the purchase price (less shipping). This limited warranty is not transferable.

### **Limitations on the Warranty**

This limited warranty does not cover: (a) normal wear and tear; (b) damage through abuse, neglect, misuse, or as a result of any accident or in any other manner; (c) damage from misapplication, overloading, or improper installation; (d) improper maintenance and repair; and (e) product alteration in any manner by anyone other than Us, with the sole exception of alterations made pursuant to product instructions and in a workmanlike manner.

### **Obligations of Purchaser**

You must retain Your product purchase receipt to verify date of purchase and that You are the original purchaser. To make a warranty claim, contact Us at 1-800-222-5381, identify the product by make and model number, and follow the claim instructions that will be provided. The product and the purchase receipt must be provided to Us in order to process Your warranty claim. Any returned product that is replaced or refunded by Us becomes our property. You will be responsible for return shipping costs or costs related to Your return visit to a retail store.

### **Remedy Limits**

Product replacement or a refund of the purchase price is Your sole remedy under this limited warranty or any other warranty related to the product. We shall not be liable for: service or labor charges or damage to Your trailer incurred in removing or replacing the product; any damages, including, without limitation, damages to tangible personal property or personal injury, related to Your improper use, installation, or maintenance of the product; or any indirect, incidental or consequential damages of any kind for any reason.

### **Assumption of Risk**

You acknowledge and agree that any use of the product for any purpose other than the specified use(s) stated in the product instructions is at Your own risk.

### **Governing Law**

This limited warranty gives You specific legal rights, and You also may have other rights, which vary from state to state. Some states do not allow limitations or exclusions on implied warranties or incidental or consequential damages, so the above limitations may not apply to You. This limited warranty is governed by the laws of the State of Minnesota, without regard to rules pertaining to conflicts of law. The state courts located in Dakota County, Minnesota shall have exclusive jurisdiction for any disputes relating to this warranty.



Distributed by  
Northern Tool + Equipment Co., Inc.  
Burnsville, Minnesota 55306  
NorthernTool.com  
Made in Thailand