

OWNER'S MANUAL

INSTALLATION AND OPERATION INSTRUCTIONS

1/2 HP CAST IRON SUBMERSIBLE SEWAGE PUMP



MODEL 107792

SEWAGE PUMP

WARRANTY: PRODUCT DEFECTS COVERED 12 MONTHS FROM DATE OF PURCHASE. RECEIPT AND PRODUCT DATE CODE REQUIRED FOR WARRANTY CLAIM

THANK YOU FOR PURCHASING

Please read and save these instructions. Read carefully before attempting to assemble, install, operate or maintain the product described. Protect yourself and others by observing all safety information. Failure to comply with instructions could result in personal injury and/or property damage! Retain instructions for future reference.

IMPORTANT NOTICE

This unit has been designed to pump water only. This unit is not designed for applications involving salt water, brine or any other liquids including petroleum products. Use with salt, brine or any other liquids including petroleum products will void the warranty. For pumping systems using more than one pump, each pump needs to be connected to a separate dedicated circuit protected by a fuse or breaker. This way, all the pumps will not stop operating if the fuse of one of the pumps burns or if the breaker of one of the pumps trips. The following are minimum requirements in order to protect your residence from flooding. It is a small investment but it is your personal responsibility to protect your home, family and valuables. Failure to comply with the following requirements will also void your warranty:

- Two (2) pumps have to be installed in the sewage pit. The first pump as a primary pump and the second pump as the backup unit.
- An alarm system has to be installed to advise you of any malfunctions. Pump selection, and proper and adequate installation are a must to comply with local by-laws and need to be adhered to.

SPECIFICATIONS

HP	1/2
Volt/ph	115/1
HZ	60
RPM	3450
Temperature	33 to 104°F (1 to 40°C) continuous
Discharge size	2" (5 cm) female national pipe thread (NPT)
Solids handling	Up to 2" (5 cm)

SAFETY GUIDELINES

Please read this before installing or operating pump. This information is provided for your safety and to prevent equipment problems. Most accidents can be avoided by using common sense. Do not wear loose clothing that may become entangled in the impeller or other moving parts.

- Always wear appropriate safety gear, such as safety glasses, when working on the pump or piping.
- Only qualified personnel should install, operate, and repair pump.
- Make sure lifting handles are securely fastened each time before lifting.
- Do not lift pump by the power cord.
- Do not exceed manufacturer's recommendation for maximum performance, as this could cause the motor to overheat.
- Secure the pump in its operating position so it cannot tip over, fall, or slide.
- Keep hands and feet away from impeller when power is connected.
- Operation against a closed discharge valve will cause premature bearing and seal failure on any pump.
- Any wiring of pumps should be performed by a qualified electrician. For electrical connection, use a rigid metal conduit joined with watertight seal.
- Cable should be protected at all times to avoid punctures, cuts, bruises, and abrasions inspect frequently.
- Do not remove cord and strain relief. Do not connect conduit to pump.
- Mastercraft® Canada is not responsible for losses, injury, or death resulting from a failure to observe these safety precautions, or the misuse or abuse of pumps or equipment.



DANGER!

- Do not pump hazardous materials (flammable, caustic, etc.) unless the pump is specifically designed and designated to handle them.
- Submersible pumps are not investigated for use in swimming pools, recreational water installations, decorative fountains, or any installation where human contact with the pumped fluid is common.
- Do not remove the round ground prong on the power cord plug or use an adaptor (cheater plug) that eliminates the ground prong. A shock hazard is created and serious injury can result if the plug is modified, or an adaptor is used.



CAUTION!

- Do not wear loose clothing that may become entangled in the impeller or other moving parts.
- Pumps build up heat and pressure during operation. Allow time for pumps to cool before handling or servicing.
- Keep clear of suction and discharge openings. Do not insert fingers in pump with power connected.
- Never operate a pump with a power cord that has frayed or brittle insulation.
- Never handle connected power cords with wet hands. Never operate a 115 V pump with a plug-in type power cord without a ground fault circuit interrupter.



WARNING!

- To reduce risk of electrical shock, all wiring and junction connections should be made per the Canadian Electrical Code (CEC) and applicable provincial and local codes. Requirements may vary depending on usage and location.
- To reduce risk of electrical shock, always disconnect the pump from the power source before handling or servicing.

UNPACKING

- Upon receiving the pump, it should be inspected for damage or shortages. If damage has occurred, file a claim immediately with the carrier that delivered the pump. If the manual is removed from the packaging, do not lose or misplace.

STORAGE

- Short Term—Pumps are manufactured for efficient performance following short, inoperative periods in storage. For best results, pumps can be retained in storage, as factory assembled, in a dry atmosphere with constant temperatures for up to six (6) months.
- Long Term—For storage of six (6) months, to twenty-four (24) months, the units should be stored in a temperature-controlled area: a roofed-over, walled enclosure that provides protection from the elements (rain, snow, wind-blown, dust, etc.), and where the temperature can be maintained between 4 and 40°C (40 and 120°F). If extended high humidity is expected to be a problem, all exposed parts should be inspected before storage and all surfaces that have the paint scratched, damaged, or worn should be recoated with a waterbased, air-dry enamel paint. All surfaces should then be sprayed with a rust-inhibiting oil.
- Pump should be stored in its original shipping container. On initial start up, rotate impeller by hand to assure seal and impeller rotate freely. If it is required that the pump be installed and tested before the long-term storage begins, such installation will be allowed, provided that:
- The pump is not installed under water for more than one (1) month.
- Immediately upon satisfactory completion of the test, the pump is removed, thoroughly dried, repacked in the original shipping container, and placed in a temperature controlled storage area.

DISCHARGE

- Discharge piping should be as short as possible. Both a check valve and a shut-off valve are recommended for each pump being used. The check valve is used to prevent backflow into the sump. Excessive backflow can cause flooding and/or damage to the pump.
- The shut-off valve is used to stop system flow during pump or check valve servicing.

ELECTRICAL CONNECTIONS

- An acceptable motor control switch shall be provided at the time of installation.
- Power Cable—The cord assembly mounted to the pump must not be modified in any way except for shortening to a specific application. Any splice between the pump and the control panel must be made in accordance with all applicable electric codes. It is recommended that a junction box, if used, be mounted outside the sump or be of at least NEMA 4 construction if location within the wet wall. Do not use the power cable to lift pump.

WIRE SIZE

- Consult a qualified electrician for proper wire size.

PRE-OPERATION: CHECK VOLTAGE AND PHASE

- Before operating pump, check to make sure that the voltage and phase information stamped on the pump's identification plate matches the available power.

IDENTIFICATION PLATE

- Note the numbers on the pump's identification plate and record at the end of the manual for future reference.

INSULATION TEST

- Before the pump is put into service, an insulation (megger) test should be performed on it. The ohm values as well as the volts and amps should be recorded.

PUMP-DOWN TEST

- After the pump has been properly wired and lowered into the basin, sump, or lift station, it is advisable to check the system by filling with liquid and allowing the pump to operate through its pumping cycle. The time needed to empty the system, or pump down time, should be recorded.

MAINTENANCE

- As the motor is oil-filled, no lubrication or other maintenance is required.

INITIAL START UP PROCEDURES

1. Inspect the pump and the sewage tank for any obvious condition that may necessitate cleaning, correction, adjustment or repair.
2. Assure that the pump is secure and vertical for proper operation.
3. Assure that there is adequate clearance from any combustible materials or structure. Stored materials must be kept away from the pump. Shelves or cabinet structures must not be in close proximity over the pump.
4. Assure that the motor is securely plugged into a proper 'GFCI' electrical outlet.
5. Test the 'GFCI' outlet by pressing its test switch. This should prove that the outlet is energized and will trip off to protect against a ground fault. Be sure to reset the 'GFCI' by pressing its reset switch (repeat this step monthly).
6. Lift the float to assure that the pump will start when required. (Step 7 below will test submersible pumps with enclosed floats).
7. Pour pails of water in the sewage tank to turn the pump on. Assure that any check valve present will permit the sewage to flow.
8. Observe that the plumbing can pump the sewage safely out of the residence. (Repeat this step monthly)

INSTALLATION STEPS

See the diagram prior to installation.

Sewage system typical piping

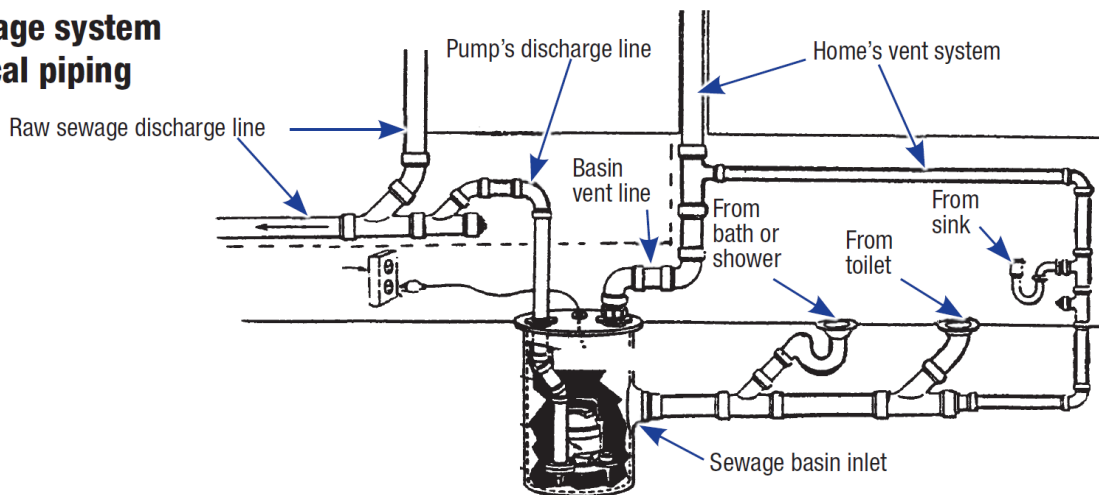

1. We recommend that you install your pump and basin in a clean location where there is adequate room for servicing at a later date. Protection from freezing temperatures and good ventilation should be considered as well, to provide the pump an environment for long life. Assuming that you have a sewage pit located in your basement floor, your pit is probably constructed from concrete, brick, tile, or more recently a sump basin made from plastic and/ or fiberglass. The minimum size of your sump pit must be 18" (45.7 cm) in diameter and no less than 25" (63.5 cm) deep. When pit is ready, proceed to next step. Friction losses in the discharge pipe must be taken into consideration when many elbows and fittings are installed in the discharge line. Each elbow or fitting must be considered as 1' (30 cm) of head.

Never run the pump dry. Damage to the seal may occur. **The run of the pipe from the check valve to the existing waste or drain line must never be sloping downward except when connecting to same.**

2. For a new installation, install your sewage basin in the excavation you have provided in the basement floor of your home. Connect the necessary piping from your shower trap, toilet, etc., to the inlet of your sewage basin, with the proper pipe and fittings (see diagram next page).
3. Cut a length of 40 to 42" (101.6 to 106.7 cm) of 2" (5 cm) ABS/DWV pipe. Cement the 2" (5 cm) ABS/DWV male adaptor to 2" (5 cm) slip to one end of this pipe.
4. With your drill, make a 1/4" (6 mm) hole in the adaptor previously glued. This hole will prevent any air locking which might occur.
5. Screw the pipe with the male adaptor into the 2" (5 cm) discharge opening in the pump. Lower pump with piping attached into the sewage basin. Make sure that the pump is as close as possible to the center of the basin. Adjusting the pump to the center of the basin will keep mechanical float switch from rubbing on side of basin.
6. When you are pumping raw sewage, you must have a gas-tight cover on the basin and a vent pipe from basin, connecting to home's vent system (see diagram below). Feed the 2" (5 cm) riser pipe from pump's discharge, through the 2" (5 cm) opening in the cover. Secure a 3" (7.6 cm) vent pipe to the cover and bring the switch and pump motor power cables through the opening in the cover provided.
7. Install a 2" (5 cm) check valve union type to the 2" (5 cm) discharge riser pipe coming out of the cover, to a length of 2" (5 cm) ABS/DWV pipe, and run the discharge line as short a distance as possible to the home's waste sewer line. Secure the check valve with the provided clamps. Be sure that the arrow on the valve is pointing away from pump.



WARNING

This unit is not designed for applications involving salt water or brine. Use with salt water or brine will void the warranty.



WARNING

Never make adjustments to any electrical appliance or product with the power connected. Do not only unscrew the fuse or trip the breaker, remove the power plug from the receptacle.

8. Connect the 3-prong plug of the switch to a receptacle. Insert the motor 3-prong plug into female receptacle on exposed piggy-back of switch plug. The mechanical switch provided for automatic operation is preset to pump. No adjustments are necessary.
9. Fill the sewage basin with water to test the operation of the submersible sewage pump and switch operation. Pump should start pumping when the water level reaches 2 to 10" (5 to 25 cm) above the bottom of the basin and above the pump. Allow the pump to go through several "ON-OFF" cycles to assure satisfactory operation.
10. Secure the gas-tight cover and the plug for electrical cords with the gaskets and screws provided with the cover. Make the vent connection to home's vent system.

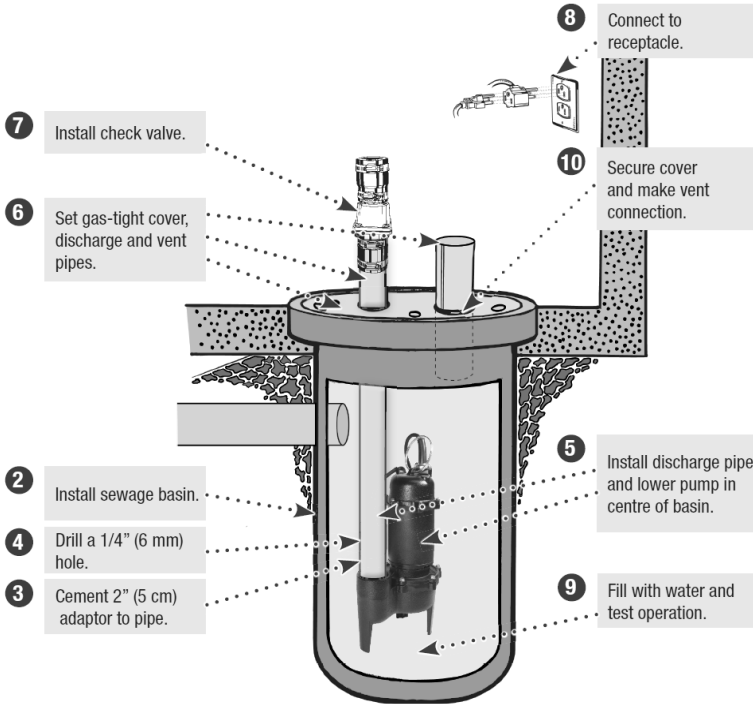



NOTE:

- Never conduct maintenance or repair work while the pump is operating.
- Plug the pump plug into a GFI receptacle. One cycle of operation should be observed so that any potential problems can be corrected.

PARTS LIST

No.	Description	Qty.
1	Power cable	1
2	Power cable adaptor	1
3	Upper casing	1
4	Capacitor	1
5	Upper bearing cover	1
6	Upper bearing	1
7	Seal plate	1
8	Volute base	1
9	Impeller	1
10	Mechanical seal	1
11	Oil seal	1
12	Lower bearing	1
13	Body cap screw	1
14	Motor housing	1
15	Stator	1
16	O-Ring	1
17	Plug screw	1
18	Handle	1
19	Mechanical float switch	1

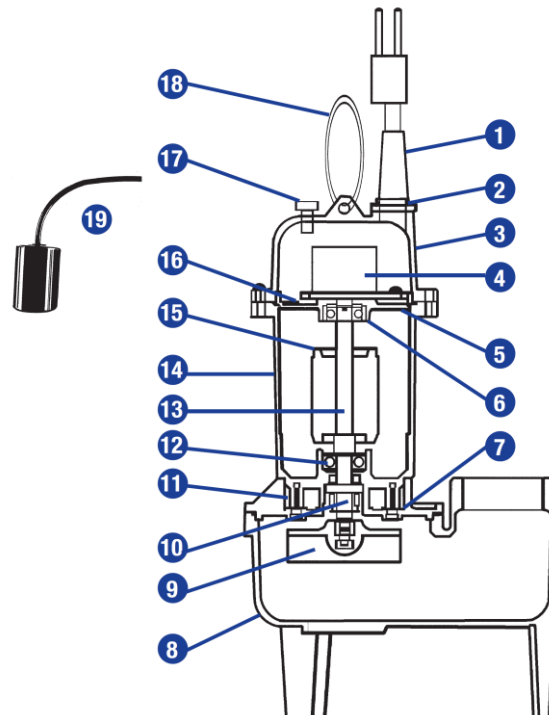

TROUBLESHOOTING CHECKLIST (CAUTION: SHUT OFF POWER TO PUMP)

Check the following before requesting service or repair.

A call out fee applies to all field services and additional labor cost may apply.

PROBLEM	POSSIBLE CAUSES	SOLUTION
Pump will not run.	Poor electrical connection, blown fuse, tripped breaker, or other interruption of power; improper power supply; thermal overcharge	Check all electrical connections for security. Have electrician measure current in motor leads. If current is within +/-20% of locked rotor Amps, impeller is probably locked. If current is 0, overload may be tripped. Remove power, allow pump to cool, then recheck current.
	Switch will not activate pump, or is defective, or in off position.	Disconnect level control. Set ohmmeter for a low range, such as 100 ohms full scale and connect to level control leads. Actuate level control manually and check to see that ohmmeter shows zero ohms for closed switch and full scale for open switch (float switch). Turn switch to on position.
	Motor or switch inoperative	Go to manual operation of pump.
	Float movement restricted.	Reposition pump or clean basin as required to provide adequate clearance for float.
	Defective motor.	Check winding insulation (megger test) and winding resistance. If check is outside of range, dry and recheck. If still defective, replace per service instructions.
Pump hums but does not run.	Insufficient liquid level.	Make sure liquid level is at least equal to suggested turn-on point.
	Incorrect voltage.	Check all electrical connections for security
Pump delivers insufficient capacity.	Impeller jammed or loose on shaft, worn, or damaged. Impeller cavity or inlet plugged.	Check impeller for freedom of operation, security, and condition. Clean impeller cavity and inlet of any obstruction
	Incorrect voltage.	Check all electrical connections for security.
	Excessive inflow or pump not properly sized for application.	Recheck all sizing calculations to determine proper pump size.
	Discharge restricted.	Check discharge line for restrictions, including ice, if line passes through or into cold areas.
	Check valve stuck closed or installed backwards.	Remove and examine check valve for proper installation and freedom of operation.
	Shut-off valve closed.	Open valve.
	Impeller jammed or loose on shaft, worn or damaged. Impeller cavity or inlet plugged.	Check impeller for freedom of operation, security, and condition. Clean impeller cavity and inlet of any obstruction.
	Pump may be airlocked	Loosen union slightly to allow trapped air to escape. Verify that turn-off level of switch is set so that impeller cavity is always flooded. Clean vent hole.
	Debris in impeller cavity or broken impeller.	Check impeller for freedom of operation, security, and condition. Clean impeller cavity and inlet of any obstruction.
	Piping attachments to building structure too rigid or too loose.	Replace portion of discharge pipe with flexible connector.
	Pump operates noisily or vibrates excessively.	Worn bearings or motor shaft bent.

ELECTRICAL PRECAUTIONS

Before servicing a pump, always shut off the power supply and then make sure you are not standing in water and that there is no risk of electrical shock. If the pump is direct-wired to the electrical circuit, contact your qualified licensed electrician to disconnect if required.

DO NOT ATTEMPT ELECTRICAL REPAIRS OF ANY SORT UNLESS YOU ARE A LICENSED ELECTRICIAN

LIMITED WARRANTY:

For one year from the date of purchase, IRONTON will repair or replace, at its option, for the original purchaser any part or parts of its Sump Pumps or Water Pumps ("Product") found upon examination by IRONTON to be defective in materials or workmanship. Please call IRONTON for instructions or see your dealer. Be prepared to provide the model number when exercising this warranty. All transportation charges on Products or parts submitted for repair or replacement must be paid by purchaser.

This Limited Warranty does not cover Products which have been damaged as a result of accident, abuse, misuse, neglect, improper installation, improper maintenance, or failure to operate in accordance with IRONTON's written instructions.

THERE IS NO OTHER EXPRESS WARRANTY. IMPLIED WARRANTIES, INCLUDING THOSE OF MERCHANTABILITY AND FITNESS FOR A PARTICULAR PURPOSE, ARE LIMITED TO ONE YEAR FROM THE DATE OF PURCHASE. THIS IS THE EXCLUSIVE REMEDY AND ANY LIABILITY FOR ANY AND ALL INDIRECT OR CONSEQUENTIAL DAMAGES OR EXPENSES WHATSOEVER IS EXCLUDED.

Some states do not allow limitations on how long an implied warranty lasts, or do not allow the exclusions or limitations of incidental or consequential damages, so the above limitations might not apply to you. This limited warranty gives you specific legal rights, and you may also have other legal rights which vary from state to state.

In no event, whether as a result of breach of contract warranty, tort (including negligence) or otherwise, shall IRONTON or its suppliers be liable for any special, consequential, incidental or penal damages including, but not limited to loss of profit or revenues, loss of use of the products or any associated equipment, damage to associated equipment, cost of capital, cost of substitute products, facilities, services or replacement power, downtime costs, or claims of buyer's customers for such damages.

You **MUST** retain your purchase receipt along with this form. In the event you need to exercise a warranty claim, you **MUST** send a **copy** of the purchase receipt along with the material or correspondence. Please call IRONTON for return authorization and instructions.