



# OIL DISPENSING SYSTEM

## OWNER'S MANUAL



**WARNING:** Read carefully and understand all **INSTRUCTIONS** before operating. Failure to follow the safety rules and other basic safety precautions may result in serious personal injury.

**Item# 107751**

Thank you very much for choosing a Roughneck™ Product! For future reference, please complete the owner's record below:

Model: \_\_\_\_\_ Purchase Date: \_\_\_\_\_

Save the receipt, warranty and these instructions. It is important that you read the entire manual to become familiar with this product before you begin using it.

This machine is designed for certain applications only. The distributor cannot be responsible for issues arising from modification. We strongly recommend this machine is not modified and/or used for any application other than that for which it was designed. If you have any questions relative to a particular application, DO NOT use the machine until you have first contacted distributor to determine if it can or should be performed on the product.

For technical questions, please call **1-800-222-5381**.

**⚠ WARNING: Read carefully and understand all INSTRUCTIONS before operating. Failure to follow the safety rules and other basic safety precautions may result in serious personal injury.**

**Save these instructions in a safe place and on hand so that they can be read when required. Keep these instructions to assist in future servicing.**

## **INTRODUCTION**

Pump: Electric self-priming rotary internal gear pump, equipped with a bypass valve

Motor: Asynchronous motor, 4-pole, closed type (Protection class IP55), self-ventilating, flange-mounted directly to the pump body.

Both systems are designed to run on 115V, 60Hz power and for use with high-viscosity oils and lubricants from a drum anywhere in your shop.

## **TECHNICAL SPECIFICATIONS**

Item	107751
<b>PUMP</b>	
Voltage	115 Volts
Frequency	60Hz
Power	900 Watts
Flow Rate	18 quarts/min. (4.5 GPM)
Pressure	175 PSI
Inlet/Outlet	1in.
Oil Viscosity	Up to 10,000 SUS
Delivery Hose	1/2in.x13ft.
<b>CONTROL VALVE</b>	
Flow rate range	0.3 - 9.2 GPM
Pressure range	7 - 750 PSI
Working Temperature	Max. 140° F
Accuracy	±0.5%
Viscosity of Fluid	8-5000 mPas
5-Digit LCD display	Liter, Quarts, Pints, Gallons
Inlet connection	1/2in. NPT Female
Spout	Rigid, Manual tip
Power source	(1) 3V CR2 battery
Cart Capacity	484 lbs.

**NOTE:** The power absorbed by the pump depends on the functioning point and the viscosity of the oil being pumped.

### Installation Dimension

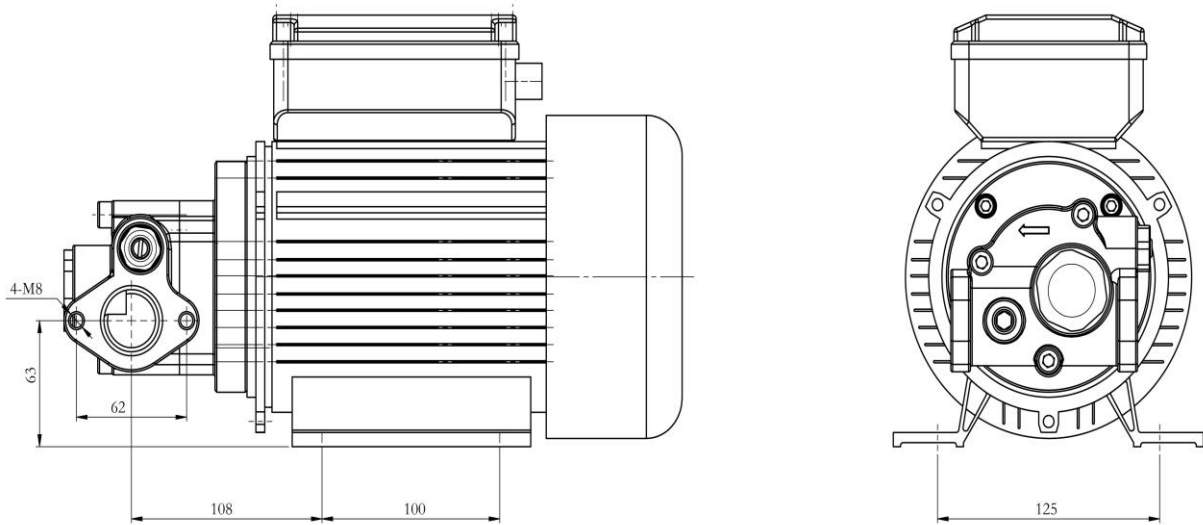



## GENERAL SAFETY REGULATIONS

**⚠ WARNING:** Read and understand all instructions.

**⚠ WARNING:** The warnings, cautions, and instructions discussed in this instruction manual cannot cover all possible conditions or situations that could occur. It must be understood by the operator that common sense and caution are factors that cannot be built into this product, but must be supplied by the operator.

- 1. Keep the work area clean and dry.** Damp or wet work areas can result in injury.
- 2. Keep children away from work area.** Do not allow children to handle this product.
- 3. Store idle equipment.** When not in use, tools and equipment should be stored in a dry location to inhibit rust. Always lock up tools and equipment, and keep out of reach of children.
- 4. Use the right tool for the job.** Do not attempt to force small equipment to do the work of larger industrial equipment. There are certain applications for which this equipment was designed. It will do the job better and more safely at the capacity for which it was intended. Do not modify this equipment, and do not use this equipment for a purpose for which it was not intended.
- 5. Check for damaged parts.** Before using this product, carefully check that it will operate properly and perform its intended function. Check for damaged parts and any other conditions that may affect the operation of this product. Replace damaged or worn parts immediately.
- 6. Do not overreach.** Keep proper footing and balance at all times to prevent tripping, falling, back injury, etc.
- 7. DO NOT use the equipment when tired or under the influence of drugs, alcohol, or medication.** A moment of inattention while operating this equipment may result in serious personal injury.
- 8. Industrial applications must follow OSHA requirements.**

## SPECIFIC OPERATION WARNINGS

	 <b>DANGER</b>
	<p>Electrical shock hazard. Electrical wiring should be done by a licensed electrician in compliance with local, state and national electrical code, ANSI/NFPA 70, 30, 30A as appropriate. Proper ground must be provided to avoid the possibility of electrical shock. Failure to comply with this warning could result in serious injury and/or loss of property.</p>

 **WARNING:** Improper use or installation of this product can cause serious bodily injury or death.

### **NOT FOR USE WITH LIQUIDS AS GASOLINE, ALCOHOL, EXPLOSIVES, CORROSIVES AND FLAMMABLE, ALIMENTARY LIQUIDS.**

Do not use the unit in an explosive environment.

Do not use the unit next to flammable liquids (gasoline, alcohol, etc.).

Do not use the unit in closed environments in presence of gasoline, LPG, methane fuelled vehicles.

Always wear suitable clothes and use suitable protective devices when cleaning, especially when removing dust or waste. Use aspirators as needed.

Never place hands or limbs under moving parts.

Disconnect power to pump before servicing pump.

NEVER overload.

## OPERATING CONDITIONS

### 1. ENVIRONMENTAL CONDITIONS

**Temperature:** Min 14°F (-10°C) / Max +140°F (+60°C)

**Relative Humidity:** Max 90%

 **WARNING:**

The temperature limits should be applied to the pump components and must be respected to avoid possible damage or malfunction.

Nevertheless, it should be understood that for a given oil, the real functioning temperature range also depends on the variability of the viscosity of the oil itself with different temperatures. Specifically:

- Under the temperature below 14°F, the viscosity of some oils can greatly exceed the maximum allowed by this pump, which will cause that the static torque required to start the pump would be excessive, and the pump may overload and damage.
- Under the temperature above +140°F, on the other hand, the viscosity of some oils can drop well below the minimum allowed by this pump, which will cause that the back pressure increases, and the pump may degrade in performance with obvious reductions in flow rate.

### 2. ELECTRICAL POWER SUPPLY

The AC pump must be supplied by a single-phase alternating current line whose nominal values are shown in the table TECHNICAL SPECIFICATIONS above. The maximum acceptable variations from the electrical parameters are:

**Voltage:** ± 5% of the nominal value

**Frequency:** ± 2% of the nominal value

**⚠ WARNING:**

Power from lines with values outside the indicated limits can damage the electrical components.

### 3. WORKING CYCLE

Under normal operating conditions they can function continuously with no limitations.

**⚠ WARNING:**

DO NOT KEEP THE PUMP WORK IN BYPASS CONDITION MORE THAN 2 MINUTES.

Whenever a particular installation carries the risk of functioning in bypass mode for longer periods of time, it is necessary to return the bypassed flow to the suction tank, but not recirculated inside the pump.

### 4. FLUID ALLOWED / FLUIDS NOT ALLOWED

**ALLOWED:** Oil with a Viscosity from 500 to 2000 Cst (at working temperature)

NOT ALLOWED	RELATED DANGER
Gasoline	Fire - explosion
Inflammable liquids with PM < 55°C	Fire - explosion
Water	Oxidation of the pump
Liquid food products	Contamination
Corrosive Chemicals	Corrosion of the pump Injury to people
Solvents	Fire – explosion Damage to gasket seals

**⚠ WARNING:** The gear pump is sensitive to polluted fluids; avoid dispensing fluids with impurities.

## INSTALLATION

**NOTE: Apply Teflon® to all connecting fittings.**

Unpack the package, and take out the mobile body, handle and accessories.

1. Take out the up handle, insert it on the trolley (See Fig. 1)

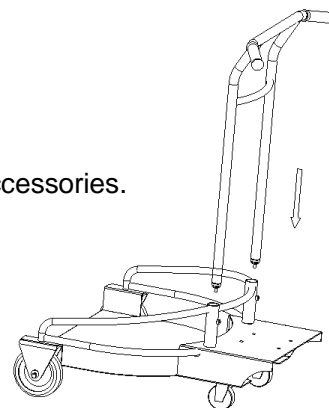

Fig. 1

2. Screw & fix the handle tightly. (See Fig. 2)



Fig. 2

3. Install the pump on the plate, tightly screwed, Screw the suction hose & delivery hose on the pump, Connect the nozzle with the pump. (See Fig. 3)

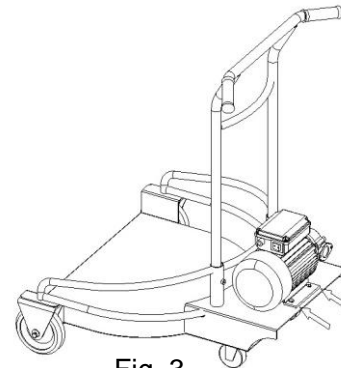

Fig. 3

## HYDRAULIC CONNECTION

- Before connection, make sure that the hoses and the suction tank are free of dirt and thread residue that could damage the pump and its accessories.
- Always install a metal mesh filter in the suction hose.
- Before connecting the delivery hose, partially fill the pump body with oil to avoid the pump running dry during the priming phase.

### Suction Hose

- Minimum nominal recommended diameter: 1in.
- Use a hose suitable for functioning under suction pressure.

### Delivery Hose

- Minimum nominal recommended diameter: 1in.

### **WARNING:**

1. Hoses and/or line components unsuitable for use with oil or with inadequate nominal pressures can cause damage to objects or people, as well as pollution.
2. Use oil resistant pipe sealant or Teflon® Tape on all pipe threads.
3. Check all the connections before each use. Tighten them if necessary. Loosening of the connections (threaded connections, flanging, gasket seals) can cause serious ecological and safety problems.

## SUCTION AND DELIVERY LINES

### DELIVERY

The proper pump should be chosen considering the viscosity of the oil to be pumped and the characteristics of the system attached to the delivery of the pump. The improper application of the oil viscosity and the characteristics of the system could create unexpected large back pressure which may cause the (partial) opening of the pump bypass and consequently reduce the flow rate.

It is recommended to use shorter tubing and/or tubing with a larger diameter to reduce system resistance, so that the pump would function equally to the viscosity of the oil being pumped.

### SUCTION

The gear-type oil pumps are characterized by excellent suction capacity. In fact, the characteristic flow rate/back pressure curve remains unchanged even at high pump suction pressure values.

The pump will prime to a height of 6.5 feet (2 meters) when the suction hose is empty and the pump is filled with fluid. On tanks with a suction height over 6.5 feet, a foot valve may be required on the bottom of the

---

suction tube to hold the fluid in the tube. Do not install the pump with a height higher than 9.8 feet (3 meters), or the pump will lose its prime.

**⚠ WARNING:** In cases where the suction tank is installed higher than the pump installation, it is recommended to install an anti-siphon valve to prevent accidental diesel fuel leaks. Care should be taken during the installation process in order to control back pressure.

## **DAILY USE**

**NOTE:** Before use, make sure all the connections are sealed well.

1. Place the drum on the trolley.
2. Put the suction hose into the drum. Move the mobile unit to where you need to dispense.
3. Put the nozzle to where you need to dispense, then connect the power cord. Turn on the switch, and start dispensing.
4. After dispensing, close the pump, and take back the nozzle.

**⚠ WARNING:** Running in bypass mode with the delivery closed is only allowed for brief periods (2 minutes maximum).

## **USAGE OF THE OIL DIGITAL CONTROL VALVE**

### **1. INSTALLATION**

Control valve is 1/2" oil inlet, when connecting with hose fitting, please remember to apply the Teflon for better seal.

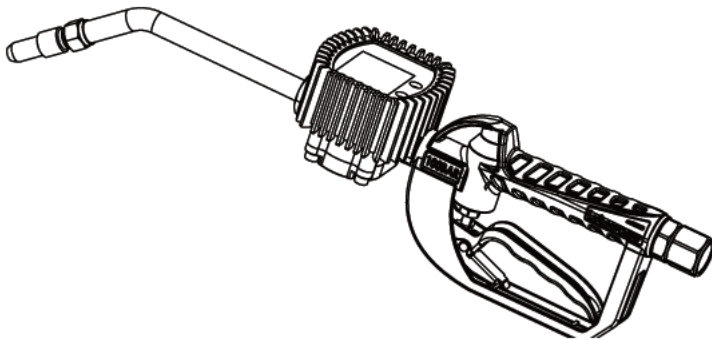

### **2. Meter**

5-digital liquid crystal display for both volume each time and total.

4 units: L, GAL, PT and QT.

Accurate to the second decimal place.

Low battery indicator.

2 buttons: "Move", "Reset".

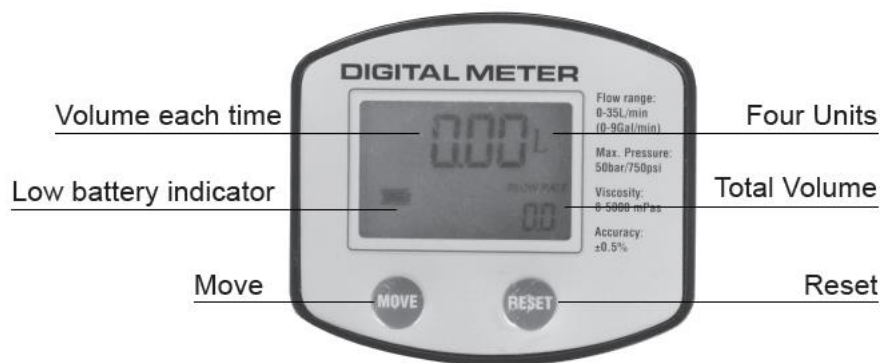

### 3. Button usage

The turbine digital meter features two buttons (MOVE and RESET) which individually perform two main functions and together, other secondary functions.

The main functions performed are:

For the reset key, resetting the partial Register and reset table total (reset total)

For the move key, entering instrument calibration mode.

Used together, the two keys permit entering configuration mode, When replacing the battery, please open the cover, remove the plug and replace the battery.

### 4. Changing the battery

Battery type: Lithium CR2, 3V/1400mAh.

Last for 8 years of operation, corresponds to approx. 500,000 litres (132,000 US GAL).

Change the battery like below when the battery signal is flashing on the display.

Remove the protector cover, unscrewing the screw.

Change the battery and screw the lid on again.

### 5. BATTERY REPLACEMENT

When replacing the battery, please open the cover, remove the plug and replace the battery.

### 6. LCD DISPLAY

#### KEY

- 1) Partial register (5 figures with moving comma from 0.1 to 99999), Indicating the volume dispensed since the reset button was last pressed.
- 2) Indication of battery charge.
- 3) Indication of calibration mode.
- 4) Indication of resetting present total to Zero.
- 5) Total register.
- 6) Indication of flow rate mode.
- 7) Indication of unit of measurement of partial: L= Litres. GAL = Gallons.
- 8) PT = Pints.
- 9) QT = Quarts.

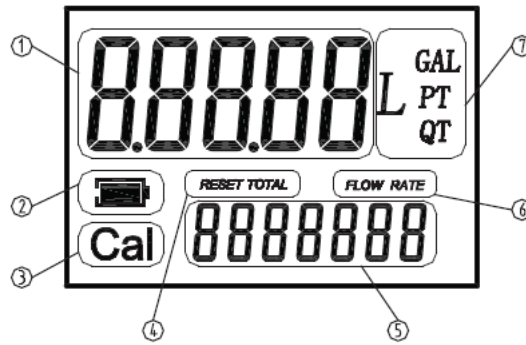

**DAILY USE**

**BUTTON USAGE, CALIBRATION AND MEASUREMENT UNIT CHANGE**

**Reset the present total (See Fig. 4)**

- 1) When the meter is on standby, press the RESET key.
- 2) The display shows all the segments.
- 3) The meter resets the present total already.



Fig. 4

**Show current correction factor and general total (See Fig. 5)**

Press MOVE and RESET together and hold for less than 3 seconds. Value "1.4000" is the correction factor which can be reset; "1234567" is the general total which cannot be reset.



Fig. 5

**Measurement unit change (See Fig. 6)**

Press MOVE and RESET together and hold for more than 3 seconds.

Zone 7 on the display is the current unit. Press RESET to chose a different measurement unit and then press MOVE and hold for more than 3 seconds to confirm.

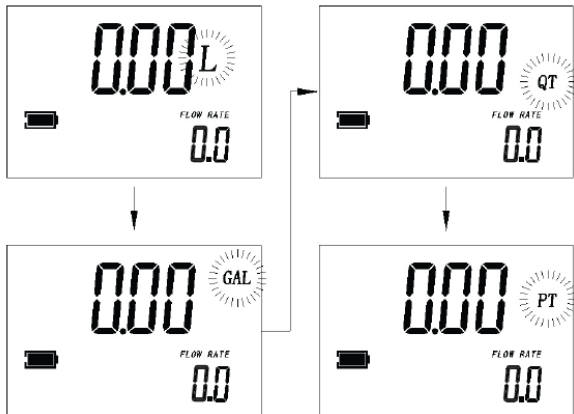

Fig. 6

### Reset The Resettable Total (See Fig. 7)

When the meter is on standby, press the RESET key for more than 3 seconds to reset the present total first.

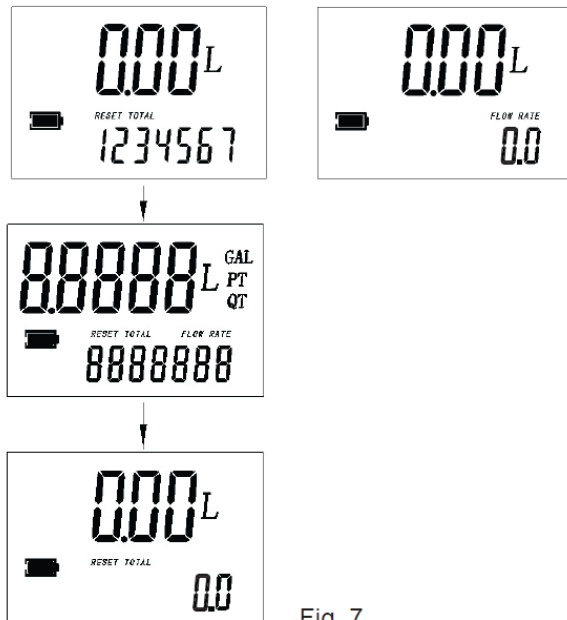

Fig. 7

### PROCEDURE FOR ENTER THE CORRECTION FACTOR DIRECTLY





Carefully follow the procedure indicated below.

#### FORMULA

Proper correction factor = current correction factor × (actual value / display value)

#### Example

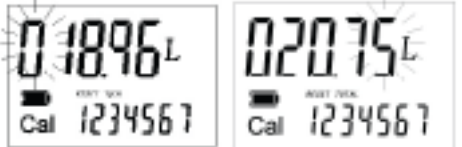
Actual value	20.75
Display value	18.96
Current correction factor	1.000
Proper correction factor	$1.000 \times (20.75 / 18.96) = 1.000 \times 1.094 = 1.094$

1	Wait for the meter to go standby.	
2	Reset the resettable total.	
3	Start dispensing into a measuring glass. Stop dispensing when over 5 Litres of volume is reached, read out the actual value. The volume that is displayed on the LCD is the Display Value, not the Actual Value which may be slightly higher. For example, in the figure on the right, the Display Value is 18.96 while the Actual Value is 20.75.	
4	Press the MOVE key. Keep it pressed until it shows as the right fig., with the digit flashing in ① zone. Press the MOVE key to go the next digit so that the Actual Value can be input.	
5	Make sure the correction factor is right and then press the MOVE key. Keep it pressed until calibration is finished and the factor is save. The meter will then return to be on standby.	

**USAGE INSTRUCTION**

- (1) Start: Turn on the trigger to make the oil transmission.
- (2) Keep the status: Push the lock ahead, then the transmission can be kept when the trigger is released.
- (3) Finish:
  - a. If the lock is not used, release your hand, the trigger will turn off and finish the transmission.
  - b. If the lock is used, please turn on the trigger once again, the lock will stop working. Then turn off the trigger, release your hand, the transmission will be finished.

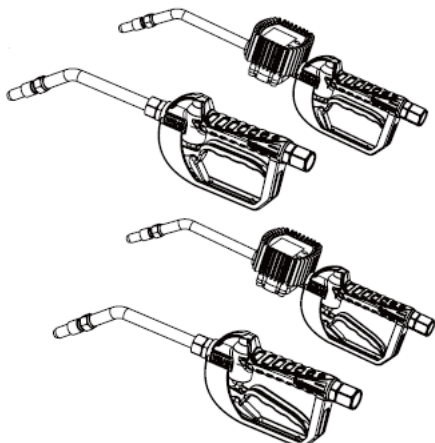

**Notes When Using: Cautions:**

- 1) For working condition, please refer to the specification parameter list. Temperature: -10°C~60°C.
- 2) Medium: Lubricant Oil.

**DIAGRAMS AND PARTS LIST**

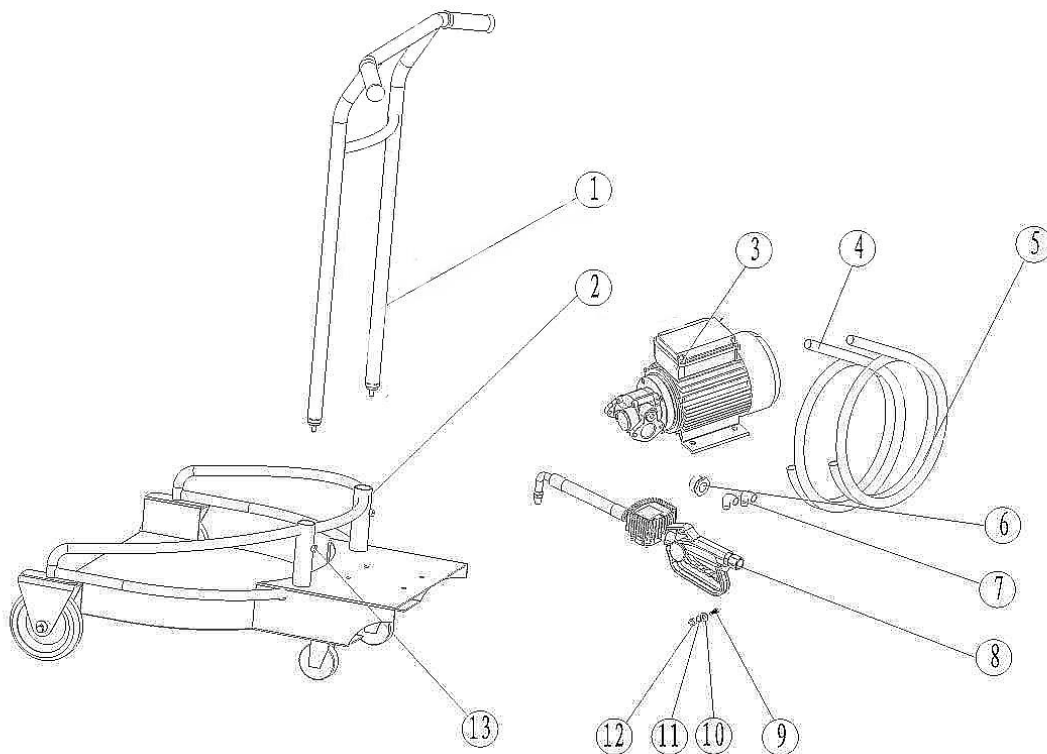

No.	Description	Quantity	No.	Description	Quantity
1	Handle	1	8	Dispensing Nozzle	1
2	Trolley	1	9	Bolt M8	4
3	Gear Pump	1	10	Flat Washer	6
4	PVC Suction Hose	1	11	Washer	4
5	Rubber Delivery Hose	1	12	Bolt M8	6
6	Hose Tail	1	13	Nut	2
7	1in. Elbow	2			

**Trolley**

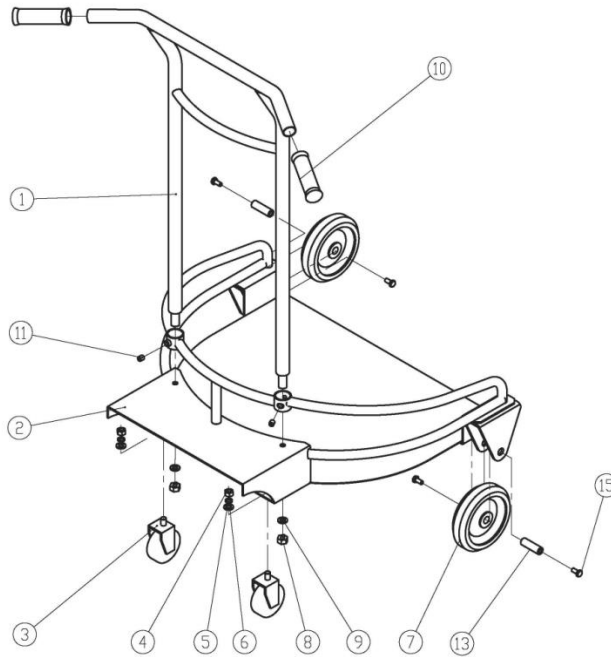

No.	Description	Quantity
1	Handle	1
2	Trolley Top	1
3	Swivel Wheels	2
4	Acorn Nut M12	2
5	Washer $\Phi 12$	2
6	Spring Washer $\Phi 12$	2
7	Wheels	2
8	Nut M10	2
9	WASHER $\Phi 10$	2
10	Handle Cover	2
11	Screw M10	2
13	Hexagon Bolt	2
15	Bolt M8x16	4

**Pump for #107751**

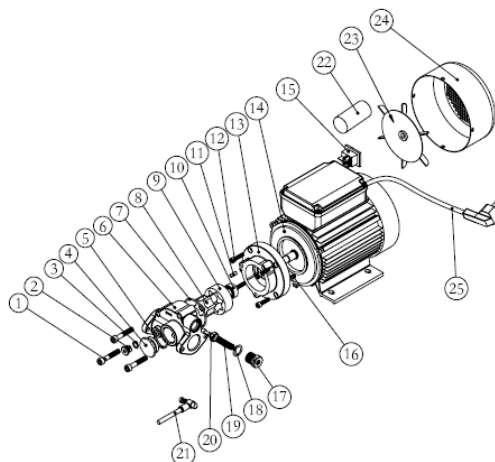

No.	Description	Quantity	No.	Description	Quantity
1	Screw M8X50	3	14	Motor	1
2	Overfall plug	1	15	Water proof switch	1
3	O-ring 11.1*1.78	1	16	Tongue	1
4	Plug G1"	1	17	By-pass plug	1
5	O-ring 29.82x2.62	1	18	O-ring 17.12x2.62	1
6	Machined pump head	1	19	Compression helical spring	1
7	O-ring 58.42x2.62	1	20	By-pass valve	1
8	Internal rotor	1	21	Venting kit	1
9	External rotor	1	22	Capacitor	1
10	Fexiseal rotry	1	23	Fan	1
11	Pin 5x15	2	24	Fan cover	1
12	Screw M6X25	4	25	Power cord	1
13	Pump flange	1			

**Control valve for #107751**

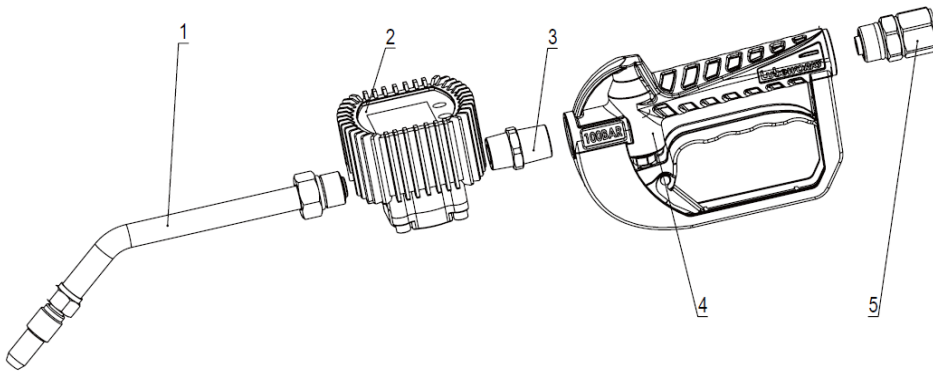

Part #	Description	Q'ty
1	Spout	1
2	Meter	1
3	Adapter	1
4	Handle Body	1
5	Swivel Fitting	1

**MAINTENANCE**

If any problem, please contact your local service center.

## TROUBLE SHOOTING

Problem	Problem	Solution
Slow or no fluid flow	Filter is clogged, or pump pressure is low, or shut-off valve is not fully open, or foreign material is jammed in the metering element.	Relief the pressure. Loose swivel fitting, clean or replace the filter. If the problem remains, contact your distributor for repair or replacement.
Oil leaks from swivel	Swivel is loose	Torque the swivel If the problem remains, contact your distributor for repair or replacement
	O-ring is worn or damaged	Replace the o-ring. If the problem remains, contact your distributor for repair or replacement
Oil drips from nozzle	Nozzle is damaged or obstructed	Inspect the nozzle for damage or obstructions, and replace if damaged If the problem remains, contact your distributor for repair or replacement
Valve leaks	O-rings or valve seat are worn or damaged	Replace the o-rings and/or the valve seat. If the problem remains, contact your distributor for repair or replacement
Leakage from meter	O-ring damaged	Get the meter off from the dispense system Take off the protector Loosing four the socket head cap screws on the cover of the meter 4. Loosing eight the hex bolts on the bottom of the meter Take off the seat Check the O-ring, replacing the O-ring if it is damaged After replacing the o-ring, assemble the meter
No Display	Loosing Battery	Get the meter off from the dispense system Take off the protector Take off the labels sticks on the bottom of the meter Loosing the five socket head cap screws on the bottom of the meter Take off the seat Check the battery, replacing the battery if it is out of power After replacing the battery, assemble the
	Battery out of power	
Wrong Reading	Correction coefficient error	Reset the correction factor (follow the instructions on Page 6)



**WARNING:** Your risk from these exposures varies, depending on how often you do this type of work. To reduce your exposure to these chemicals: work in a well-ventilated area, and work with approved safety equipment, such as those dust masks that are specially designed to filter out microscopic particles.

## EXPLODED AND PARTS LIST

#15210601

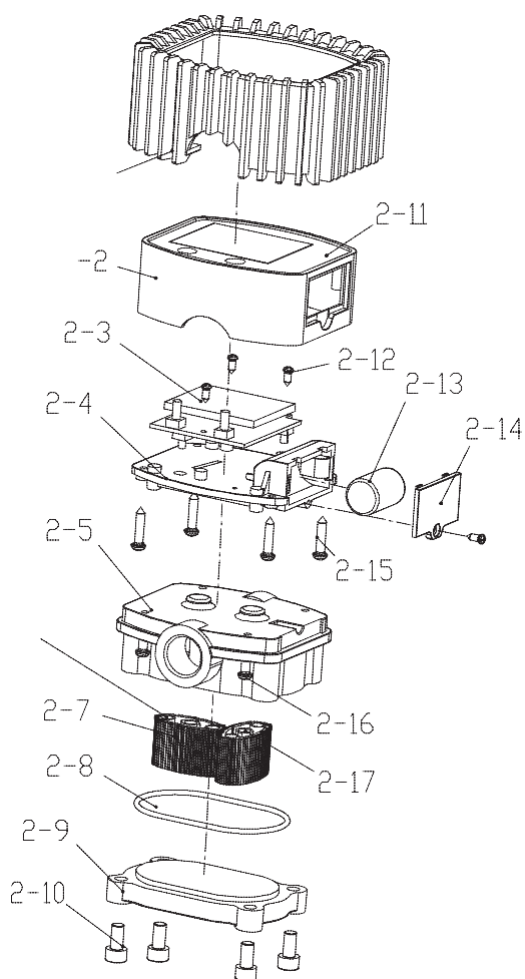

Part #	Description	Q'ty	Part #	Description	Q'ty
2-1	Rubber Protector	1	2-10	Screw	4
2-2	Meter Cover	1	2-11	Label	1
2-3	Main Circuit Board	1	2-12	Screw	4
2-4	Fix Board	1	2-13	Battery	1
2-5	Seat	1	2-14	Battery Cover	1
2-6	Magnetic Rod	2	2-15	Screw	4
2-7	Oval Gear	2	2-16	Screw	4
2-8	O-ring	1	2-17	Shaft	2
2-9	Meter Holder	1			

**EXPLODED AND PARTS LIST  
VALVE BODY EXPLODED DRAWING**

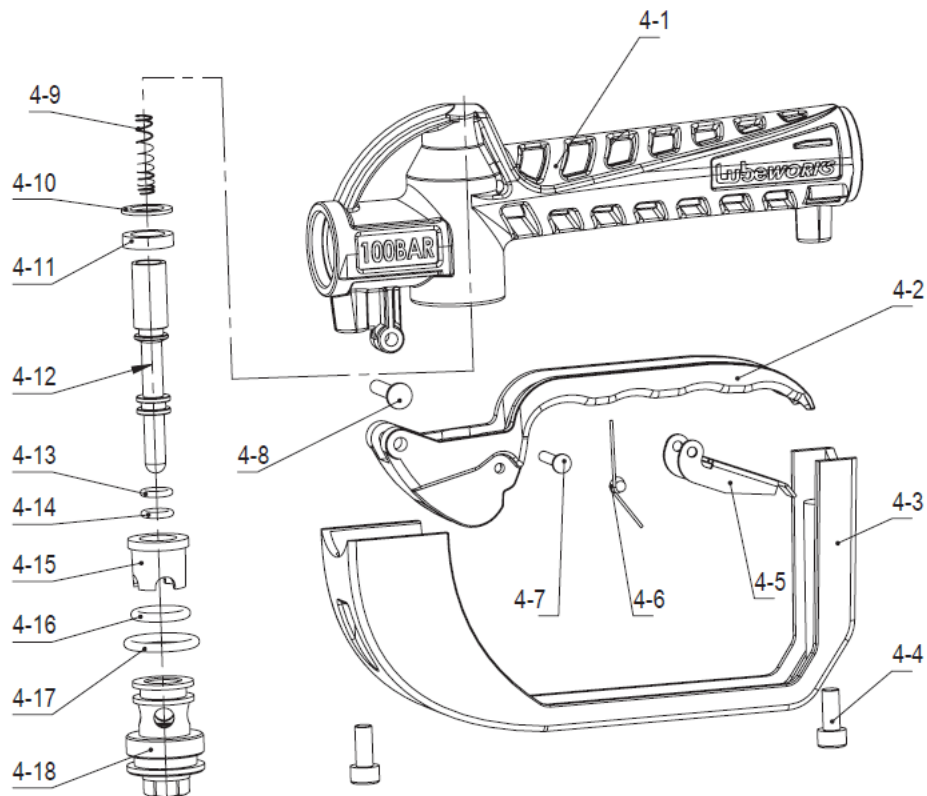

Part#	Description	Q'ty	Part#	Description	Q'ty
4-1	Handle Body	1	4-10	Washer	1
4-2	Trigger	1	4-11	Seal	1
4-3	Grip	1	4-12	Slip Pole	1
4-4	Screw	2	4-13	O Ring	1
4-5	Trigger Lock	1	4-14	O Ring	1
4-6	Clip	1	4-15	Bushing	1
4-7	Pin	1	4-16	O Ring	1
4-8	Pin	1	4-17	O Ring	1
4-9	Spring	1	4-18	Piston Sleeve	1

For replacement parts and technical questions, please call **1-800-222-5381**.

## **WARRANTY**

One-Year Limited Warranty



Distributed by  
Northern Tool + Equipment Co., Inc.  
Burnsville, MN 55306  
NorthernTool.com  
Made in China