

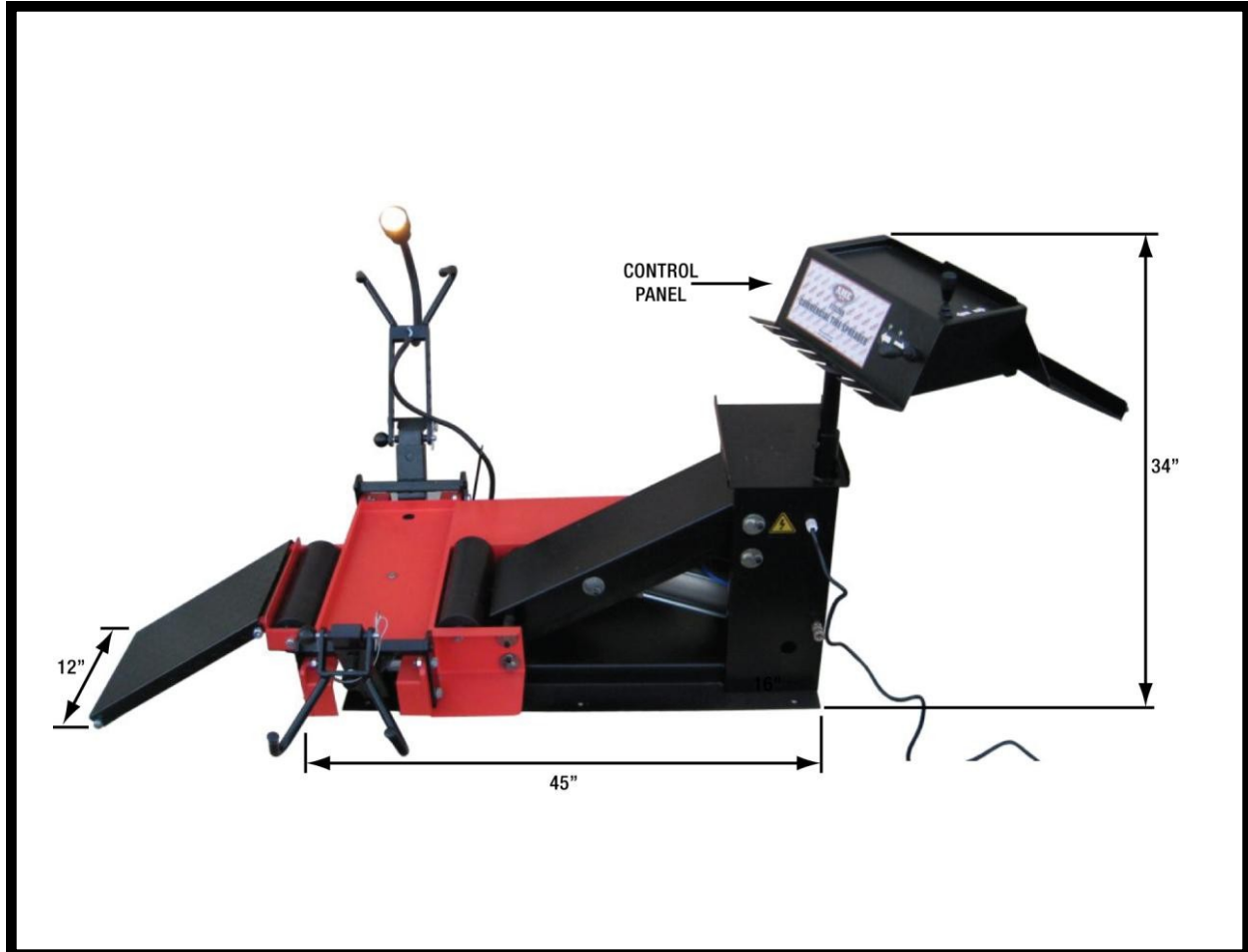

INSTRUCTION MANUAL



Model 73200

Automatic Pneumatic Truck Tire Spreader

2347 Circuit Way, Brooksville, Florida, USA 34604
Phone: (+1) 352-799-1111 Toll Phone: (+1) 877-775-4AME (4263)
Fax: (+1) 352-799-1112 E-mail: sales@ameintl.net www.ameintl.net



INSTRUCTION MANUAL

Warnings

- Please read the instruction booklet and all directions on the machine carefully and fully understand the contents before use.
- This machine is used for spreading tires or repairing protective casing of tires only. It should not be used for other applications. AME is not responsible for any of consequences resulting from improper use.
- Keep the spreading hooks and claws clean in the process of spreading. Be careful to avoid grease or other foreign material, which may cause the hooks to be slick.
- Do not use the machine if it appears worn or twisted out of shape or if it's damaged. Contact AME or your distributor for parts or repair.
- All operators should wear protective coverings throughout the process.

Product Illumination

Pneumatic tire spreader is designed to assist in fixing the tires and spreading the tires during repairing, in order to work for the tire polishing, cleaning and films affixed etc. Equipped with work light and tool rack to improve work efficiency, enable the tire repairing work to be more convenient and faster. Manifest personalized design.

Technical Parameter

Tire Width: 145MM-75MM
Tire Diameter: 11"-4"
Input Voltage: 12V
Air Pressure: 100 PSI



INSTRUCTION MANUAL

Product Structure Illumination

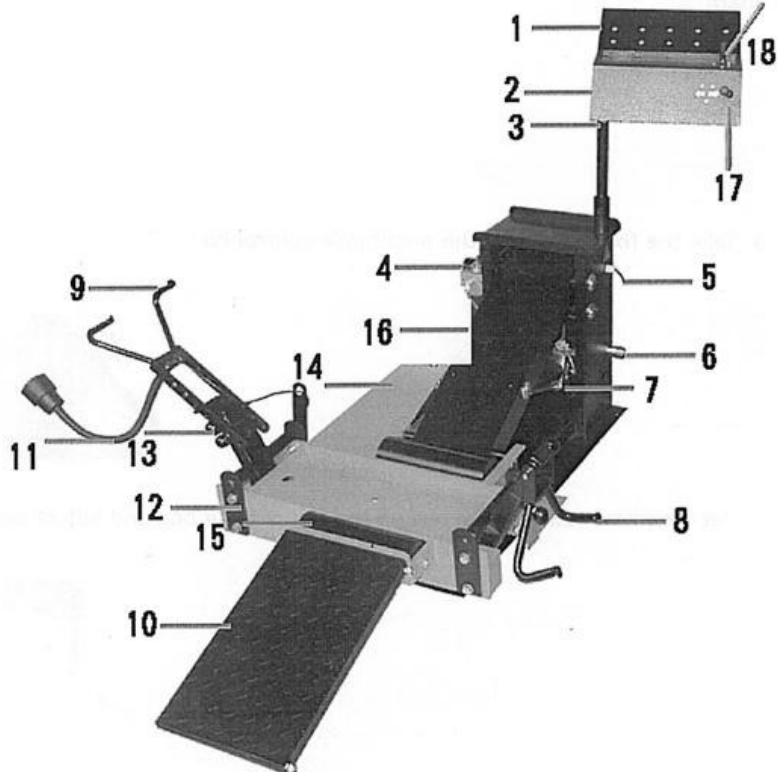

Product Structure Illumination

- | | |
|----------------------------------|---|
| (1) Tools Tray | (10) Tire platform |
| (2) Pneumatic control box | (11) Work light |
| (3) Tools racks | (12) Up & down platform |
| (4) Air regulator | (13) Adjusting valve |
| (5) Main body power | (14) Spread pneumatic cylinder |
| (6) Pneumatic union | (15) Tire lever |
| (7) Up & down pneumatic cylinder | (16) Pneumatic tools union |
| (8) Short Spread hook | (17) Spread pneumatic cylinder control valve |
| (9) Long spread hook | (18) Up & down pneumatic cylinder control valve |



INSTRUCTION MANUAL

Installation

1. Place this product on solid ground and keep it flat.
2. Remove the backboard of pneumatic control box from the inclined support board.

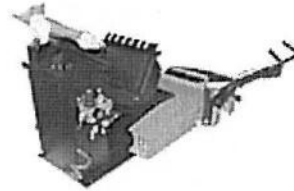

3. Take the fixed pin from the pneumatic control box.

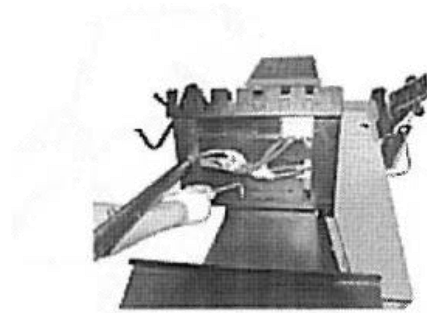

4. Put the pneumatic control box on the top of body box and adjust the well position.

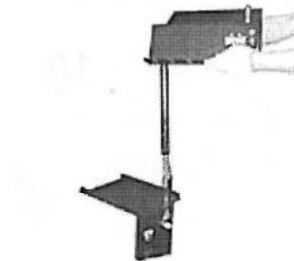

5. Connect the tools tray with pneumatic control box well.



INSTRUCTION MANUAL

6. Connect the tire sloping board with equipments well.

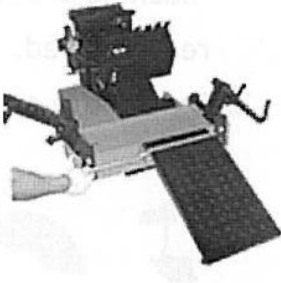
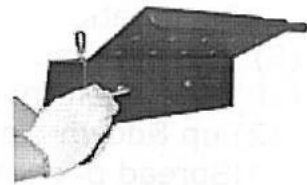

7. Connect the spread hook which equipped with work light with equipments.

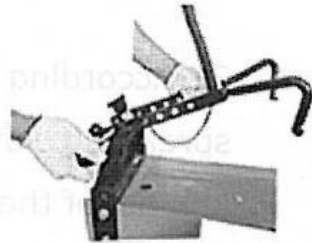

8. Connect the short spread hook with equipments.

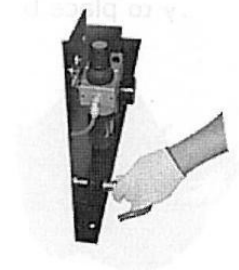

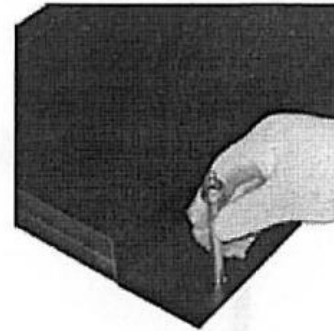

10. Keep it fixed on a flat ground with screws and keeps the screw firmness.

Operation

1. Before starting the machine, check carefully whether the fasteners on the machine are loose because of transportation. If so tighten fasteners.

2. Fix the tire on the tire spreader with claw by hand.

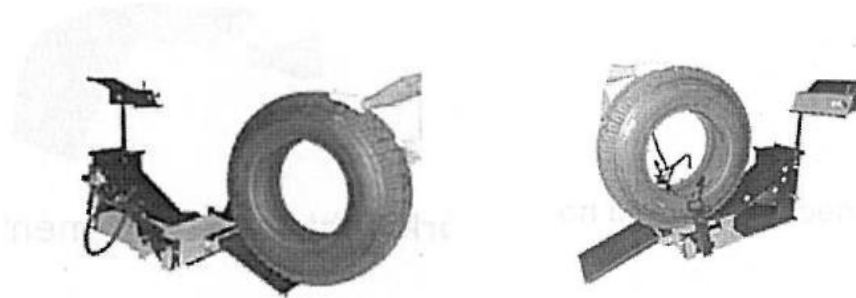

3. According to the size of the tire which needs to be repaired, to adjust the spreading claw to be the appropriate height. Place the spreading hook to link pin of the hanging device. Adjust the spreading hook up and down in order to insert into one of the adjusting holes which have 7 groups total. Put the short spread hook inside the tire and try to place the tire in the middle of tire lever if possible.

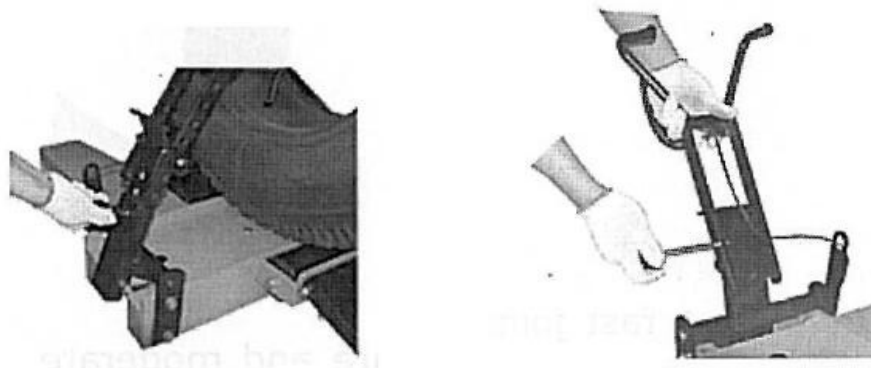



INSTRUCTION MANUAL

4. Pull the spreading control valve to the direction of spreading, and spread the tire to the width needed. The tire will probably disengage from the spreader if the spreading hook arm is too high. Operate after it is lowered and the height is properly adjusted.

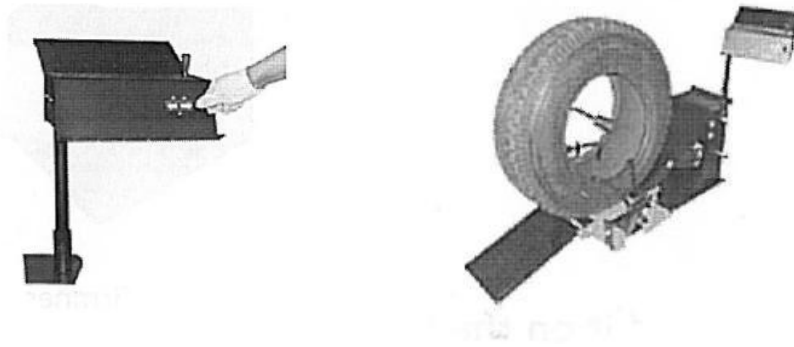

5. Pull the up & down control valve to the direction of up & down needed, raise the tire to the proper height.

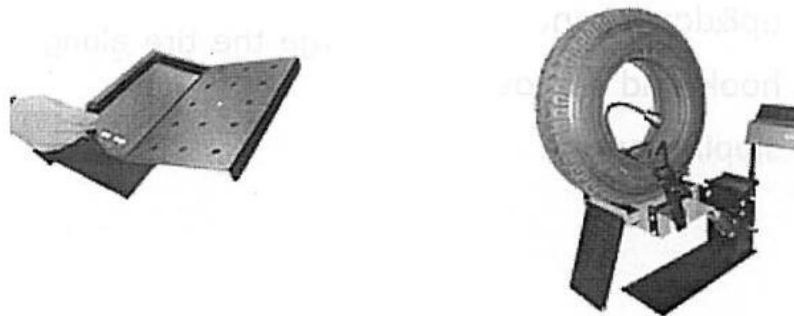

6. If it's needed to revolve the tire to a new position, please pull the spreading control valve to the direction of contraction, revolve the tire to a proper position on the machine after the spreading hooks are loosened, then operate the machine.



7. The work light fixed on the machine needs to be adjusted to a proper position, to illuminate the inside sufficiently and make the repair work easy.



INSTRUCTION MANUAL



8. After finished maintenance work, please firstly move the up & down control valve to the downward direction, let the tire fall to the lowest, then move the up & down control valve to the direction of contraction, loosen the spreading hook and remove it from the tire core, then discharge the tire along the sloping board.

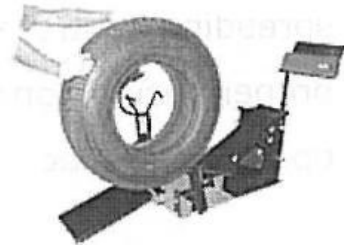
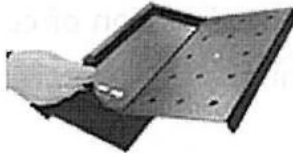
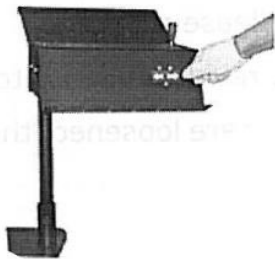

Maintenance

- Add the lubrication oil to the oil cup in time, always guarantee that the oil quantity in the cup to be occupy 1/3-2/3 of the total volume. Adjust drip oil speed, piston reciprocating run every 5-6 times for drip one blob oil for standard. Ensure the oil pathway lubricates fully.
- Clear away the dust and sundries always, check whether the fastener is loose or not.
- Drip oil to the piston rod and the various parts of pin regularly. This will reduce friction, extending machine life.



INSTRUCTION MANUAL

Caution

Before using the product, be sure to carefully read and fully understand the instructions manual and all stickers noted on the product. This is a necessary step to avoid injury to the operator and keep from damaging the product.

This product is designed only for spreading and the repairing of the tire. Do not use this product for any other purpose; AME is not responsible for any problems caused during misuse of the spreader.

Keep the hook and claw of the machine clean during operation. Clean away any dirt or debris, such as grease or lubricant, in order to avoid injury to the operator.

Do not use this product if it is visibly worn, broken, or damaged. Contact your distributor or AME for technical assistance or for replacement parts.

Appropriate eye protection should be worn at all times when working with the spreader. This product should only be used by trained professionals.



Product Illumination

This vertical pneumatic car tire spreader is designed for fixing tires and spreading tires during repair, in order to work for tire patching and cleaning, this unit is equipped with a work light and tool rack to improve work efficiency, and also make repair work be faster and more convenient.



INSTRUCTION MANUAL

Body Assembly Parts Breakdown

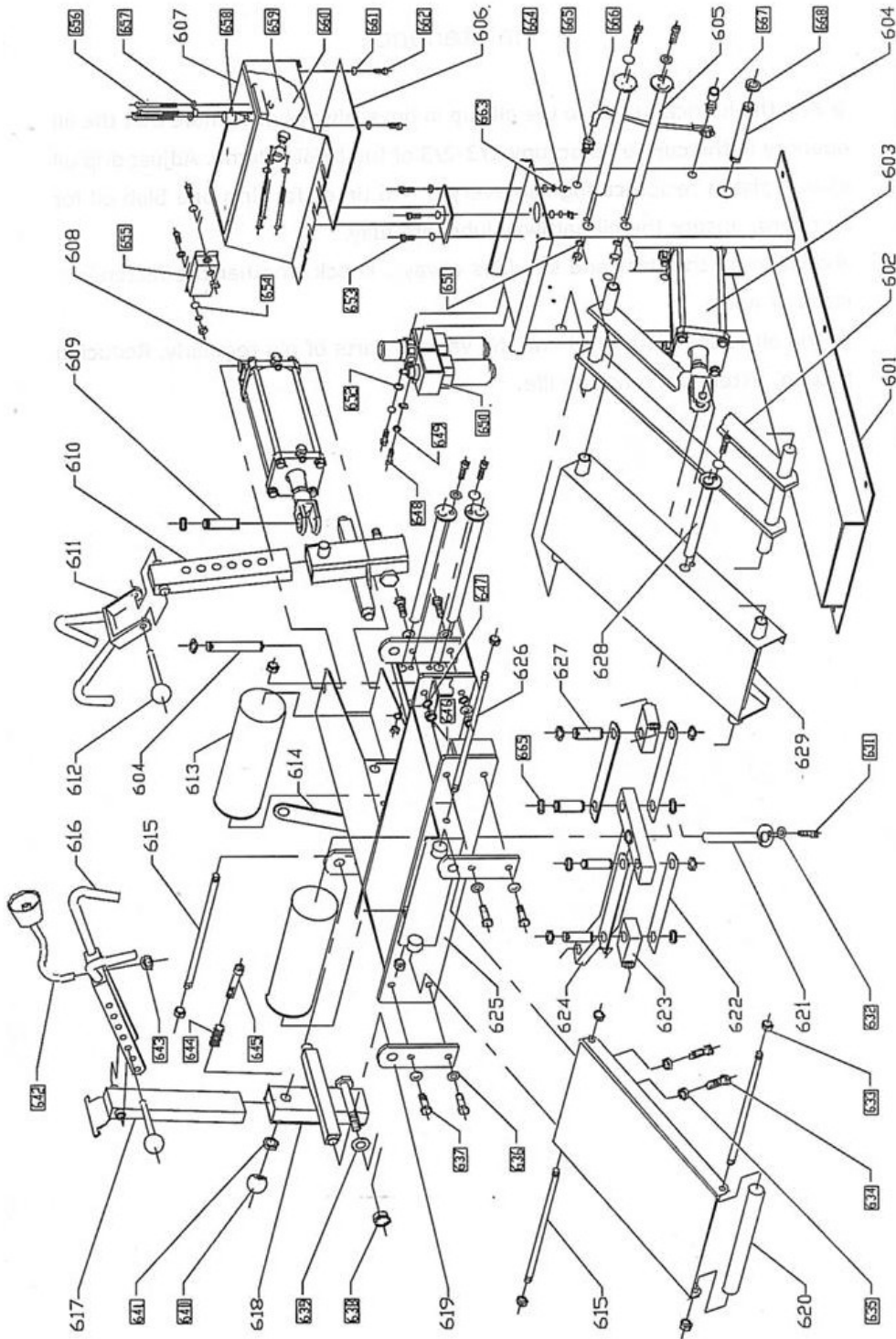



INSTRUCTION MANUAL

Body Assembly Parts List

No.	Description	QTY
73200-601	Body	1
73200-602	Swinging frame	1
73200-603	Up pneumatic cylinder	1
73200-604	Pneumatic cylinder shaft	2
73200-605	Shaft 1	4
73200-606	Motherboard of pneumatic control box	1
73200-607	Pneumatic control box	1
73200-608	Spreading pneumatic cylinder	1
73200-609	Connection union	1
73200-610	Adjustive pipe 1	1
73200-611	Short spread hook	1
73200-612	Alignment unite element	2
73200-613	Lever unite element	2
73200-614	Power line bracket	1
73200-615	Staff shaft	3
73200-616	Long spread hook	1
73200-617	Adjustive pipe 2	1
73200-618	Swing Frame	2
73200-619	Branch Union	4
73200-620	Lever unite element	1
73200-621	Shaft 3	1
73200-622	Connection board	4
73200-623	Short pulling pole	2
73200-624	Pulling Pole	1
73200-625	Up & down bracket	1
73200-626	Shaft 2	1
73200-627	Connecting-rod shaft	4
73200-628	Shaft 2	1
73200-629	Swing cover	1
73200-630	Tools tray	1
73200-631	Column hexangular bolt M8x10	6
73200-632	Washer 8	6
73200-633	Ceasing nut M12	8
73200-634	Hexangular bolt M8x30	2
73200-635	Hexangular nut M8	7
73200-636	Washer 12	12
73200-637	Hexangular bolt M12x40	8
73200-638	Ceasing nut M16	2
73200-639	Washer 16	2
73200-640	Handle ball B-M10x32	2
73200-641	Coarse thread Hexangular flat bolt M10	2
73200-642	work light	1
73200-643	Hexangular flat bolt M10	1
73200-644	Compressing spring	2
73200-645	Column hexangular bolt M10x50	2
73200-646	Hexangular nut M12	8



INSTRUCTION MANUAL

Body Assembly Parts List

No.	Description		QTY
73200-647	Spring washer	12	2
73200-648	Column hexangular bolt	M6x12	4
73200-649	Spring washer	6	2
73200-650	Air regulator		1
73200-651	Spring washer	8	5
73200-652	Big flat washer	6	2
73200-653	Column hexangular bolt	M5x16	2
73200-654	big flat washer	5	2
73200-655	Electron transformer		1
73200-656	Crossed set bolt	M4x40	6
73200-657	Washer	4	12
73200-658	Handle valve		2
73200-659	Spring washer	4	6
73200-660	Hexangular nut	M4	6
73200-661	Washer	5	12
73200-662	Column hexangular bolt	M5x10	4
73200-663	Spring washer	5	2
73200-664	Hexangular nut	M5	2
73200-665	Loop		1
73200-666	Power thread		1
73200-667	Metal quick connector		1
73200-668	Shaft spring loop	20	14
73200-669	Washer	6	4
73200-670	Hexangular nut	M6	2
73200-671	Column hexangular bolt	M8x12	1