

USER'S GUIDE FOR THE

KNIFE & TOOL SHARPENER MK.2

WSKTS2

SCAN TO WATCH
VIDEO INSTRUCTIONS



 **WORK SHARP**
SHARPENERS

⚠ WARNING! To reduce the risk of injury, the user must read and understand this instruction manual before using product. Save these instructions for future reference.

THANK YOU!

Thank you for purchasing a Work Sharp Knife & Tool Sharpener. As the CEO, and 4th generation to lead our family's company I am excited that you have put your trust in our company and products. Darex is filled with exceptional people who have each done their part to get this product in your hands. Our mission is that you are left surprised and delighted by your experience and I hope we have delivered.

At Darex, we strive to make every sharpening experience easy, fast, and effective. I am confident you will find the performance and precision you expect in this high quality sharpening system. With this breakthrough approach to sharpening, you can now sharpen your tools much faster. It will work every time.

If you have questions, suggestions, or need help with your **WORK SHARP®** unit, please contact us. Our customer service representatives are here to help. We support what we build and we appreciate hearing from you!

Though we believe operating your **WORK SHARP®** will be intuitive, please read this User's Guide to ensure you achieve the superior results you desire. We have included some sharpening tips you may find handy. Please visit our website at www.worksharptools.com.

There you will find:

- Demonstrations of all operations with the sights and sounds leading to successful knife sharpening
- Downloadable copies of this User's Guide
- Warranty registration
- Service and contact numbers

Thank you again for buying a **WORK SHARP®** Knife & Tool Sharpener. Enjoy its performance. Work Smart, **WORK SHARP®**!



MATTHEW BERNARD

CEO, Darex, LLC

Maker of Work Sharp®, Drill Doctor® and Darex®

TABLE OF CONTENTS

<i>SAFETY INFORMATION</i>	4
<i>THE ANATOMY OF A KNIFE</i>	8
<i>GETTING TO KNOW YOUR KNIFE & TOOL SHARPENER</i>	9
<i>SETTING UP YOUR SHARPENER</i>	10
<i>BEST TECHNIQUES / TROUBLE SHOOTING</i>	13
<i>SHARPENING KITCHEN KNIVES</i>	14
<i>SHARPENING OUTDOOR KNIVES</i>	16
<i>SHARPENING SERRATED KNIVES</i>	18
<i>SHARPENING KNIVES WITH PARTIAL SERRATIONS</i>	19
<i>SHARPENING GUT HOOKS</i>	20
<i>SHARPENING SINGLE-BEVEL KNIVES</i>	21
<i>SHARPENING SCISSORS</i>	22
<i>SHARPENING EDGED TOOLS</i>	23
<i>SHARPENING CUTTING TOOLS</i>	24
<i>SHARPENING MOWER BLADES</i>	25
<i>GRINDING, POLISHING, DEBURRING</i>	26
<i>WARRANTY</i>	27

PLEASE LEAVE A REVIEW ON [AMAZON](https://www.amazon.com), [WORKSHARPTOOLS.COM](https://www.worksharptools.com)
OR WHEREVER YOU PURCHASED YOUR PRODUCT



SAFETY INFORMATION

You will be creating incredibly sharp knives and tools with this sharpener. Please handle them with care. Use caution to avoid cutting yourself.

GENERAL POWER TOOL SAFETY WARNINGS



⚠ WARNING! Read all safety warnings, instructions, illustrations and specifications provided with this power tool. Failure to follow the warnings and instructions may result in electric shock, fire and/or serious injury.

Save all warnings and instructions for future reference. The term “power tool” in the warnings refers to your mains-operated (corded) power tool or battery-operated (cordless) power tool.

SAVE THESE INSTRUCTIONS

1) WORK AREA SAFETY

- a) **Keep work area clean and well lit.** Cluttered or dark areas invite accidents.
- b) **Do not operate power tool in explosive atmospheres, such as in the presence of flammable liquids, gases or dust.** Power tools create sparks which may ignite the dust or fumes.
- c) **Keep children and bystanders away while operating a power tool.** Distractions can cause you to lose control.

2) ELECTRICAL SAFETY

- a) **Power tool plugs must match the outlet. Never modify the plug in any way. Do not use any adapter plugs with earthed (grounded) power tools.** Unmodified plugs and matching outlets will reduce risk of electric shock.
- b) **Avoid body contact with earthed or grounded surfaces such as pipes, radiators, ranges and refrigerators.** There is an increased risk of electric shock if your body is earthed or grounded.
- c) **Do not expose power tools to rain or wet conditions.** Water entering a power tool will increase the risk of electric shock.
- d) **Do not abuse the cord. Never use the cord for carrying, pulling or unplugging the power tool. Keep cord away from heat, oil, sharp edges or moving parts.** Damaged or entangled cords increase the risk of electric shock.
- e) **When operating a power tool outdoors, use an extension cord suitable for outdoor use.** Use of a cord suitable for outdoor use reduces the risk of electric shock.
- f) **If operating a power tool in a damp location is unavoidable, use a ground fault circuit interrupter (GFCI) protected supply.** Use of an GFCI reduces the risk of electric shock. (It is recommended that the tool is always supplied via a residual current device with a rated residual current of 30 mA or less.)

3) PERSONAL SAFETY

- a) **Stay alert, watch what you are doing and use common sense when operating a power tool. Do not use a power tool while you are tired or under the influence of drugs, alcohol or medication.** A moment of inattention while operating power tool may result in serious personal injury.
- b) **Use personal protective equipment. Always wear eye protection.** Protective equipment such as dust mask, non-skid safety shoes, hard hat, or hearing protection used for appropriate conditions will reduce personal injuries.
- c) **Prevent unintentional starting. Ensure the switch is in the off-position before connecting to power source and/or BATTERY pack, picking up or carrying the tool.** Carrying power tools with your finger on the switch or plugging in power tools that have the switch on invites accidents.
- d) **Remove any adjusting key or wrench before turning the power tool on.** A wrench or a key left attached to a rotating part of the power tool may result in personal injury.
- e) **Do not overreach. Keep proper footing and balance at all times.** This enables better control of the power tool in unexpected situations.
- f) **Dress properly. Do not wear loose clothing or jewelry. Keep your hair, clothing and gloves away from moving parts.** Loose clothes, jewelry or long hair can be caught in moving parts.
- g) **If devices are provided for the connection of dust extraction and collection facilities, ensure these are connected and properly used.** Use of dust collection can reduce dust-related hazards.
- h) **Do not let familiarity gained from frequent use of tools allow you to become complacent and ignore tool safety principles.** A careless action can cause severe injury within a fraction of a second.

4) POWER TOOL USE AND CARE

- a) **Do not force the power tool. Use the correct power tool for your application.** The correct power tool will do the job better and safer at the rate for which it was designed.
- b) **Do not use the power tool if the switch does not turn it on and off.** Any power tool that cannot be controlled with the switch is dangerous and must be repaired.
- c) **Disconnect the plug from the power source and/or remove the BATTERY pack, if detachable, from the power tool before making any adjustments, changing accessories, or storing power tools.** Such preventive safety measures reduce the risk of starting the power tool accidentally.
- d) **Store idle power tools out of the reach of children and do not allow persons unfamiliar with the power tool or these instructions to operate the power tool.** Power tools are dangerous in the hands of untrained users.
- e) **Maintain power tools. Check for misalignment or binding of moving parts, breakage of parts and any other condition that may affect the power tools operation. If damaged, have the power tool repaired before use.** Many accidents are caused by poorly maintained power tools.
- f) **Keep cutting tools sharp and clean.** Properly maintained cutting tools with sharp cutting edges are less likely to bind and are easier to control.
- g) **Use the power tool, accessories and belts etc., in accordance with these instructions and in the manner intended for the particular type of power tool, taking into account the working conditions and the work to be performed.** Use of the power tool for operations different from those intended could result in a hazardous situation.

h) Keep handles and grasping surfaces dry, clean and free from oil and grease. Slippery handles and grasping surfaces do not allow for safe handling and control of the tool in unexpected situations. Hold the power tool by insulated gripping surfaces, because the sanding surface may contact its own cord. Cutting a "live" wire may make exposed metal parts of the power tool "live" and could give the operator an electric shock.

5) SERVICE

a) Have your power tool serviced by a qualified repair person using only identical replacement parts. This will ensure that the safety of the power tool is maintained.

DAREX,LLC

Mail 210 E. Hersey St. Ashland OR 97520 USA

Phone 1 (800) 597-6170

Fax 1 (541) 552-1377

E-mail info@darex.com

Web www.worksharptools.com

b) Do not dispose of electrical products with household waste. Waste electrical products should not be disposed of with household waste. Please recycle where facilities exist. Check with your local authority or retailer for recycling advice.



c) To replace a damaged power supply cord (Type Y), your power tool must be returned to the Service Center.

BELT SANDER SAFETY RULES

⚠ WARNING: Hold the power tool by insulated gripping surfaces, because the sanding surface may contact its own cord. Cutting a "live" wire may make exposed metal parts of the power tool "live" and could give the operator an electric shock.

⚠ WARNING: ALWAYS use proper safety glasses. Everyday eyeglasses are NOT safety glasses. Also use face or dust mask if operation is dusty. **ALWAYS WEAR CERTIFIED SAFETY EQUIPMENT.**

⚠ WARNING: Use of this tool can generate and/or disperse dust, which may cause serious and permanent respiratory or other injury. Always use NIOSH/ OSHA approved respiratory protection appropriate for the dust exposure. Direct particles away from face and body.

⚠ CAUTION: Wear appropriate hearing protection during use. Under some conditions and duration of use, noise from this product may contribute to hearing loss.

- **Always hold tool firmly.**
- **Use clamps or another practical way to secure and support the work piece to a stable platform.** Holding the work by hand or against your body leaves it unstable and may lead to loss of control.
- **Avoid prolonged contact with dust from power sanding, sawing, grinding, drilling, and other construction activities. Wear protective clothing and wash exposed areas with soap and water.** Allowing dust to get into your mouth, eyes, or lie on the skin may promote absorption of harmful chemicals.
- **Do NOT energize tool unless the sharpening cassette is firmly engaged in either the sharpening or grinding position.**

SAFETY GUIDELINES – DEFINITIONS

The label on your tool may include the following symbols.

V..... Volt

Hz..... Hertz

min minutes



..... direct current



..... Class II Construction



..... safety alert symbol

A amperes

W..... watts



..... alternating current

n_0 no load speed



..... earthing terminal

min^{-1} revolutions or
reciprocations per minute

MOTOR

Be sure your power supply agrees with nameplate marking. 120 VAC Volts AC only means your tool will operate on standard 60 Hz household power. Do not operate AC tools on DC. A rating of 120 volts AC means that your tool will operate on standard 60 Hz AC power. This information is printed on the nameplate. Lower voltage will cause loss of power and can result in over-heating.

INTENDED USES:

- Grinding, Sharpening and Honing applications on knives and tools
- Light duty grinding in metal
- Only for use with consumer use
- Tool should only be used with sharpening cassette installed

UNINTENDED USES:

- Industrial or commercial grinding or sharpening applications
- Extended, continuous heavy duty use beyond 30 minutes per hour

THE ANATOMY OF A KNIFE

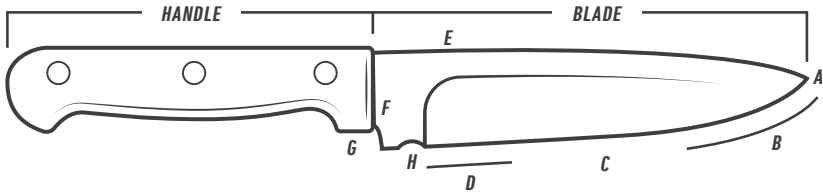

- A. POINT** The very end of the knife, which is used for piercing
- B. TIP** The first third of the blade (approximately) which is used for small or delicate work
- C. EDGE** The cutting surface of the knife, which extends from the point to the heel
- D. HEEL** The rear part of the blade, used for cutting activities that require more force
- E. SPINE** The top, thicker portion of the blade, which adds weight and strength
- F. BOLSTER** The thick metal portion joining the handle and the blade, which adds weight and balance
- G. FINGER GUARD** The portion of the bolster that keeps the user's hand from slipping onto the blade
- H. CHOIL** A notch in the blade that starts the cutting edge.

NOTE: Many pocket knives include a thumbstud to open the blade. Lower the handle when sharpening to ensure the thumbstud does not contact the abrasive belt.

NOTE: Knives are made of different steels. Softer steels will sharpen quickly. Harder steels will take longer to sharpen, but they also hold their edge longer.

GETTING TO KNOW YOUR KNIFE & TOOL SHARPENER

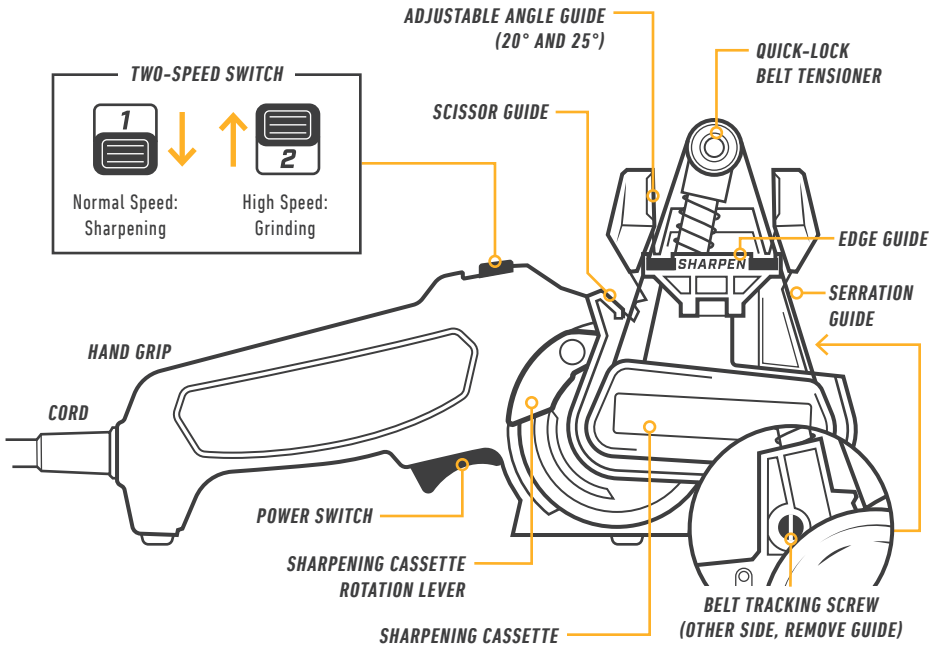

INCLUDED SHARPENING BELTS (2 EACH)

GRIT	COLOR	REPLACEMENT KITS	APPLICATION
P80	GREEN	WSSA0002703	Coarse grit belt for grinding and sharpening most tools.
P220	RED	WSSA0002704	Medium grit belt for knife and scissor sharpening.
6000	PURPLE	WSSA0002705	Fine grit belt for honing knives.

Abrasive belt dimensions: 1/2" x 12"

Replacement belts and more grit selection available at: www.worksharptools.com

SETTING UP YOUR SHARPENER

1. SHARPENING CASSETTE

Squeeze and hold sharpening cassette rotation lever and rotate the cassette up, clockwise (pressing inward to keep flush with the power base) to **SHARPEN** or **GRIND** position.

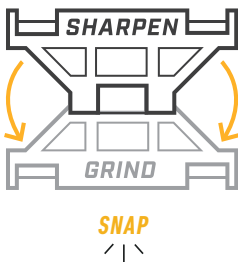
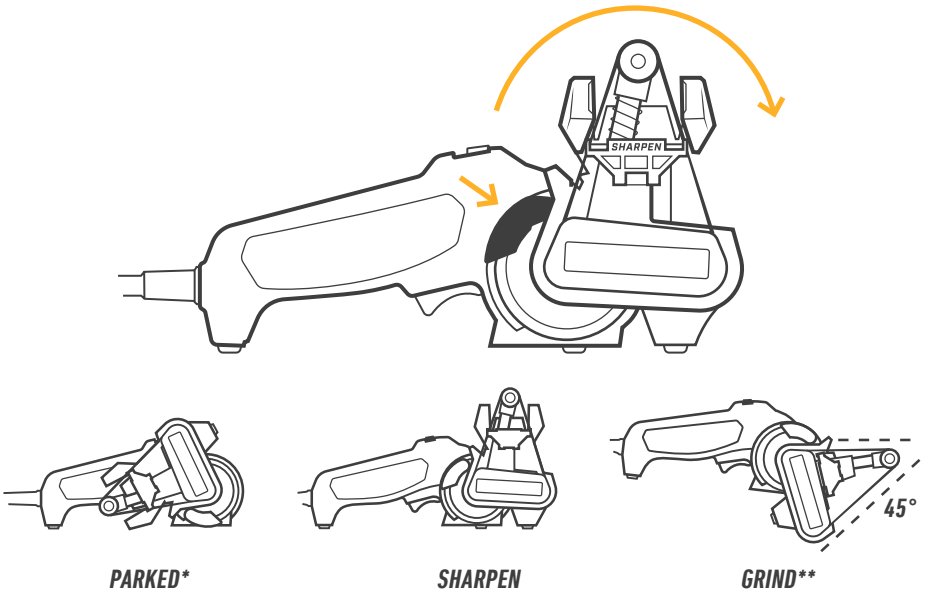

* ⚠ Do not power the sharpener while in the parked position.

** For grinding applications, remove the Angle Guide as illustrated in section 3 by pulling straight up and off and flip Edge Guide down.

2. INSTALL DESIRED BELT

These engineered abrasives are long lasting and cool cutting.

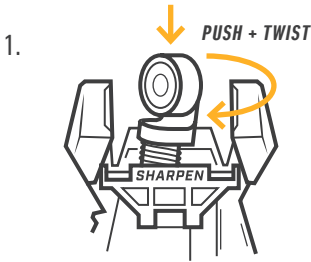

Push tensioner down and rotate clockwise $\frac{1}{4}$ turn to lock in place.

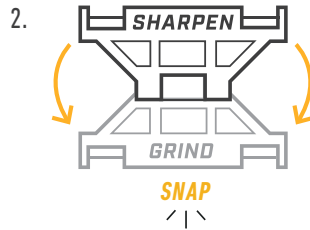

Flip Edge Guide down and out of the way to make belt changes easier. Snap into place.

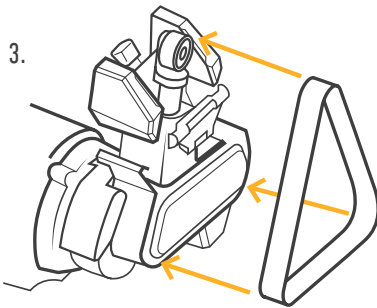

Center belt on all three pulleys.

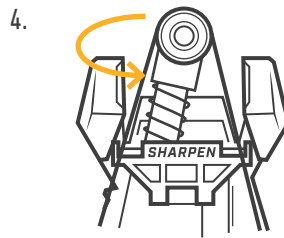

Turn tensioner $\frac{1}{4}$ turn counter-clockwise to release. Spin belt by hand to ensure properly centered on pulleys before powering up. Return the Edge Guide to the up position.

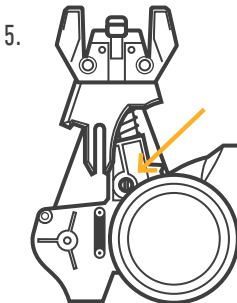

The belt tracking screw (on back of sharpener, with guide removed) can be adjusted to correct belt tracking.

3. ANGLE GUIDE

The angle guide will help create a consistent bevel across the entire edge of a blade. The guide can be set to 20° or 25°. The guide can be removed completely for belt changes or grinding tasks.

To install, align and slide the guide over the fasteners. Push until the guide snaps into place.

To remove, pull up on the guide.

NOTE: The belt tracking screw (accessible with the guide removed) can be adjusted to correct belt tracking.

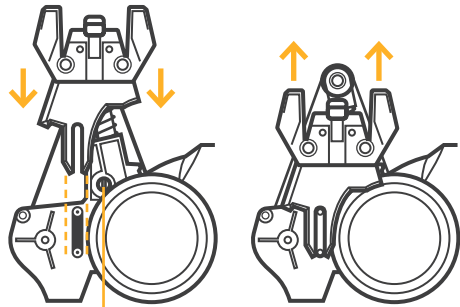

Back side of sharpener shown for reference

Adjust the angle by pushing the lever on the back of the guide up or down. The lever will snap into position.

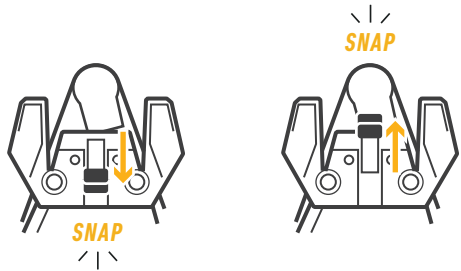

Down for 25°

Up for 20°

BEST TECHNIQUES

- Keep the blade against the amber line on Angle Guide. Place knife into the Angle Guide slot, with blade resting on Edge Guide. Maintain this position and pull knife across belt.
- Pull straight through the guide and **stop when the tip of the blade reaches the middle of the belt**.
- For blades with flat edges (see below), do not lift the blade handle.



- For blades with extreme curvature you may need to lift the handle, keeping the blade profile perpendicular to the belt.

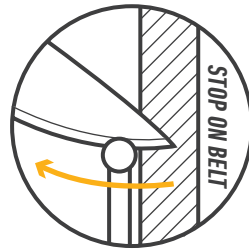
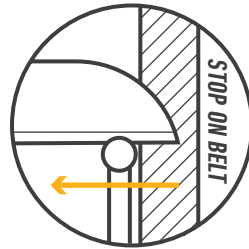
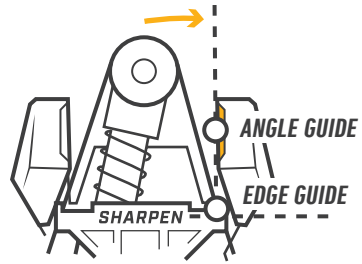

TROUBLESHOOTING:

- a) Problem:** The tips of my knives are becoming rounded.
Solution 1: Stop while the blade's tip is still supported by the belt to reduce tip rounding.
Solution 2: Keep the blade edge perpendicular to the belt to reduce tip rounding.
- b) Problem:** How do I feel for a burr at the cutting edge to know when to proceed from P220 to 6000?
Solution: Slide your finger perpendicular and away from the cutting edge. The burr will feel like a small 'ridge' or 'wire' at the edge.
- c) Problem:** My knives are cutting into the edge guide.
Solution: Use much lighter pressure. Using only the weight of the blade for best results.

NOTE: This tool is not intended for heavy-duty use; do not exceed 30 minutes use in 1 hour.

SHARPENING KITCHEN KNIVES

NON-SERRATED KNIVES ONLY

SET UP

BELT	ANGLE GUIDE	EDGE GUIDE	SPEED
RED P220	FLIP UP (20°)	UP	SHARPENING (1)

STEP 1

With knife resting on the Angle Guide and Edge Guide, squeeze power switch, and pull the knife straight and steadily through from heel to tip of blade. **Power down when the point of the blade is on the center of the belt.**

TIP: An 8" knife should take 4 seconds per stroke.

Continue until a slight burr develops on the opposite side (usually 5-10 strokes – harder steels may require more strokes).

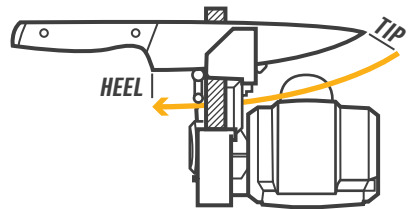
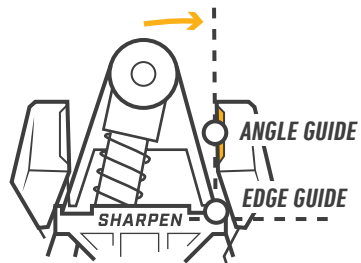

PROPER TECHNIQUE: Keep the blade in the slot, up against the amber line on the Angle Guide and with the blade resting on the Edge Guide. Maintain this position and stop as the tip reaches the center of the belt.

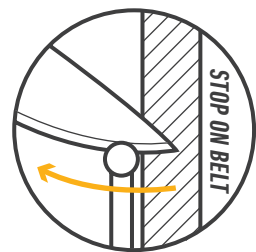

STEP 2

Repeat step 1 now using the *left side* of guide.

Repeat the same number of strokes as performed in step 1.

Your knife should now be “tomato sharp”. If you choose, you can proceed with the purple 6000 grit belt and hone the edge for even sharper results!

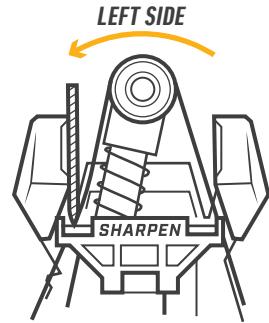

STEP 3 (OPTIONAL)

Remove red belt, install **PURPLE 6000 BELT**.

Hone the knife by alternating sides evenly until burr is removed (5 strokes per side, 10 strokes total).

RE-SHARPENING: When re-sharpening, use the **RED BELT** until a burr is formed, then the **PURPLE BELT** for 5 strokes per side.

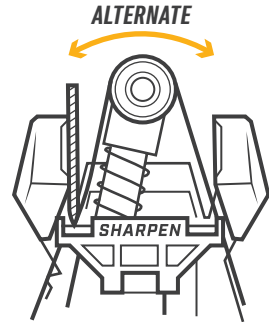

SHARPEN	
P220 RED	× 10
6000 PURPLE	× 10

RE-SHARPEN	
P220 RED	× 2 - 6
6000 PURPLE	× 10

SHARPENING OUTDOOR KNIVES

POCKET KNIVES, HUNTING KNIVES, FILET KNIVES, ETC.

SET UP

BELT	ANGLE GUIDE	EDGE GUIDE	SPEED
RED P220	FLIP DOWN (25°)	UP*	SHARPENING (1)**

STEP 1

With knife on the guides, squeeze power switch, and pull the knife straight and steadily through across the belt from heel to tip of blade. **Power off when the point of the blade is on the center of the belt.**

TIP: An 4" knife should take 2 seconds per stroke.

Repeat until a slight burr develops on the opposite side (usually 5-10 strokes – harder steels may require more strokes).

PROPER TECHNIQUE: Keep the blade in the slot, up against the amber line on the Angle Guide and with the blade resting on the Edge Guide. Maintain this position and stop as the tip reaches the center of the belt.

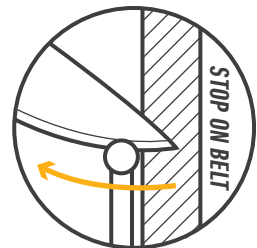
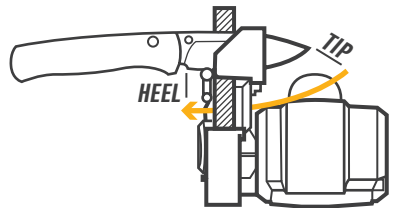
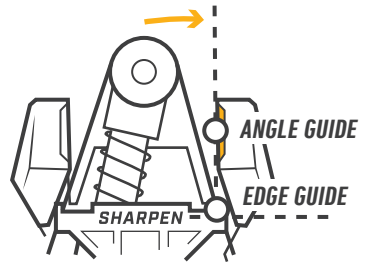

STEP 2

Repeat **STEP 1** now using the **LEFT SIDE** of guide.

Make the same number of strokes as performed on the right side.

Your knife should now be “toothy sharp”. If you choose, you can proceed with the **PURPLE 6000 GRIT BELT** and hone the edge for even sharper results!

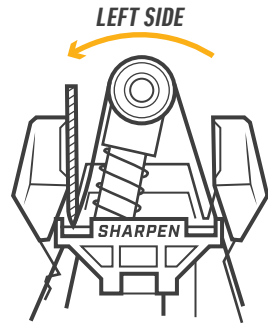

STEP 3 (OPTIONAL)

Remove red belt, install **PURPLE 6000 BELT**.

Hone the knife by alternating sides evenly until burr is removed (5 strokes per side, 10 strokes total).

RE-SHARPENING: When re-sharpening, use the **RED BELT** until a burr is formed, then the **PURPLE BELT** for 5 strokes per side.

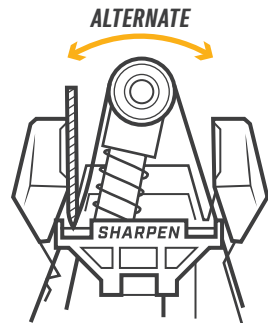

SHARPEN	
P220 RED	× 10
6000 PURPLE	× 10

RE-SHARPEN	
P220 RED	× 2 - 6
6000 PURPLE	× 10

* Some knives with thumbstuds, flipper tabs, or forward swept handles may require you to lower the Edge Guide to allow the entire length of the blade to be sharpened.

** If the knife is very damaged, and/or if chips need to be removed use #2 Speed.

SHARPENING SERRATED KNIVES

NOTE: Serrated knives have a flat side and a beveled side; sharpen only the flat side.

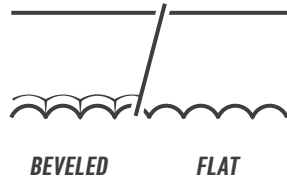

SET UP

BELT	ANGLE GUIDE	EDGE GUIDE	SPEED
PURPLE 6000	N/A	UP	SHARPENING (1)

STEP 1

Place flat side of blade against the serrated knife guide at the bolster / handle. Squeeze power switch; pull knife steadily across belt from bolster to tip of blade; 8-in. knife should take 4 seconds.

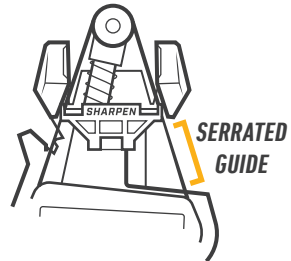

NOTE: Only place serrated blades on downhill / right side of belt; otherwise, you risk cutting the belt.

Repeat 2 to 3 strokes.

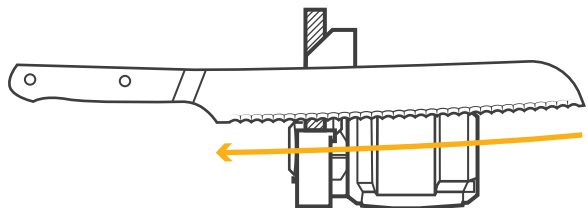

SHARPENING KNIVES WITH PARTIAL SERRATIONS

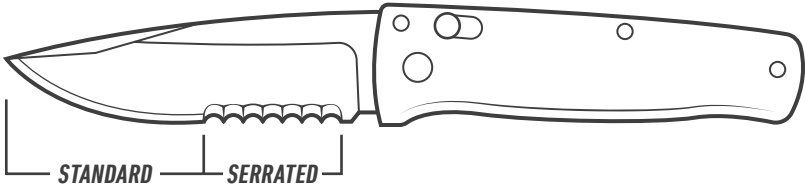

STEP 1

Follow the *SHARPENING OUTDOOR KNIVES* instructions on the standard portion of the blade using the Angle Guide set at 25°.

STEP 2

Follow the *SHARPENING SERRATED KNIVES* instructions on the serrated portion of the blade using the serrated knife guide.

SHARPENING GUT HOOKS & BLADES WITH DEEP CONCAVE CURVES

NOTE: Follow instructions **SHARPENING OUTDOOR KNIVES** on the standard portion of the blade using the Angle Guide set at 25°.

SET UP

BELT	ANGLE GUIDE	EDGE GUIDE	SPEED
PURPLE 6000	REMOVED*	DOWN	SHARPENING (1)

STEP 1

Place curve of gut hook over the belt on downhill side; allow belt to conform to blade's curve.

NOTE: Only use the downhill / right side of the belt or you will cut the belt.

Squeeze power switch; hone 2 to 4 seconds.

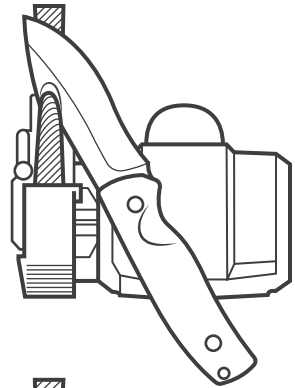

STEP 2

Repeat **STEP 1** on other side of gut hook.

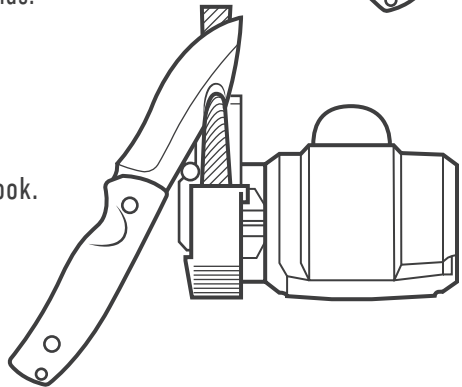

* Pull up on the Angle Guide to remove from the Sharpening Cassette.

SHARPENING SINGLE-BEVEL KNIVES

SET UP

BELT	ANGLE GUIDE	EDGE GUIDE	SPEED
RED P220	FLIP UP (20°)	UP	SHARPENING (1)

STEP 1

Follow instructions for standard-edged knives on the beveled side of the blade **ONLY**.

Continue until a slight burr develops on the flat side (usually 5 strokes.)

STEP 2

Install **PURPLE BELT** and repeat **STEP 1**.

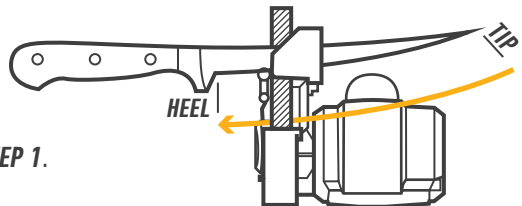

STEP 3

Hone flat side of the blade using the serrated guide.

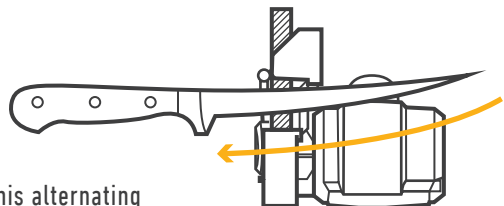

TIP: It may be necessary to repeat this alternating process of bevel sharpening and back honing to achieve the sharpest results (no burr).

SHARPENING SCISSORS

SHARPEN ONLY THE BEVELED SIDE OF YOUR SCISSORS.

Marking the beveled side with a black marker will make it easier to see when the cutting edge has been sharpened.

SET UP

BELT	ANGLE GUIDE	EDGE GUIDE	SPEED
PURPLE 6000	SCISSOR	UP	SHARPENING (1)

STEP 1

Place scissor blade in guide slot all the way to the hinge. Keep the blade flat on the guide while sharpening.

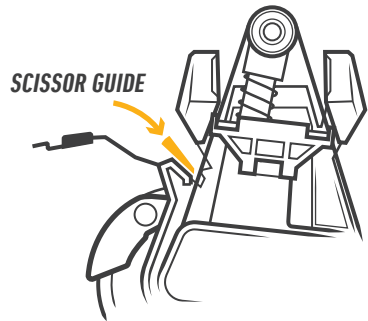

STEP 2

Pull scissors steadily through guide along full length of blade.

STEP 3

Repeat **STEP 1** about 5 times or until black marker is sharpened off.

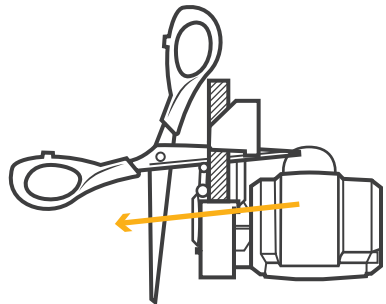

NOTE: Damaged or extremely dull scissors may need the **RED P220** Belt.

SHARPENING EDGED TOOLS

SHOVELS, HOES, AXES, PICKAXES, POST-HOLE DIGGERS, & OTHER EDGED TOOLS

NOTE: Tools such as these do not require sharpening to a precise angle; just let the belt conform to the edge of the tool. It will take longer to restore an edge to severely damaged tools.

SET UP

Rotate Sharpening Cassette into the Grinding position.



BELT	ANGLE GUIDE	EDGE GUIDE	SPEED
GREEN P80	REMOVED*	DOWN	GRINDING (2)

STEP 1

Clamp tool to be sharpened securely in bench vise.

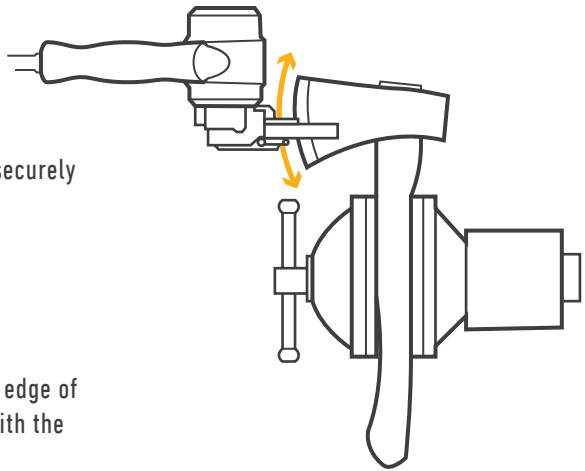

STEP 2

Squeeze power switch; grind edge of tool until you are satisfied with the sharpness.

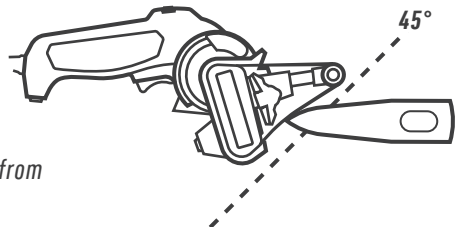

* Pull up on the Angle Guide to remove from the Sharpening Cassette.

SHARPENING CUTTING TOOLS

PRUNERS, SHEARS, & OTHER BYPASS CUTTING TOOLS

NOTE: These tools usually have only one sharp, beveled blade. **Re-sharpen ONLY the beveled blade.** These tools do not require sharpening to a precise angle; just let the belt conform to the edge of the tool.

SET UP

Rotate Sharpening Cassette into the Grinding position.



BELT	ANGLE GUIDE	EDGE GUIDE	SPEED
RED P220	REMOVED*	DOWN	GRINDING (2)

STEP 1

Clamp pruners in a bench vise.

STEP 2

Make 2 to 4 strokes or until you are satisfied with the sharpness.

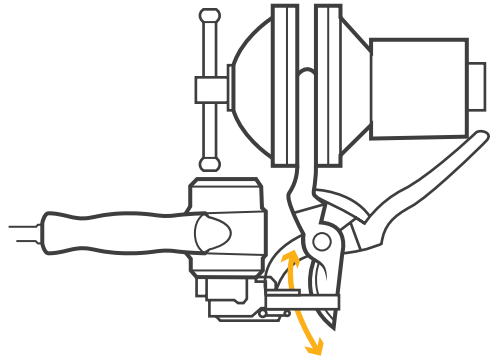

NOTE: Some tools require the anvil to be inserted through the grinding frame opening (as shown) to allow belt access to the cutting edge.

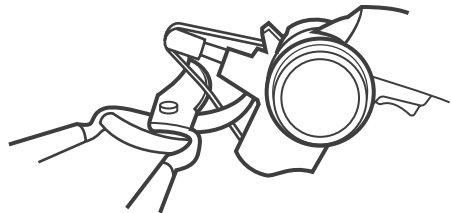

* Pull up on the Angle Guide to remove from the Sharpening Cassette.

SHARPENING MOWER BLADES

LAWN MOWER BLADES, STRAIGHT & CURVED (MULCHING) BLADES

NOTE: Lawn mower blades do not require sharpening to a precise angle; just let the belt conform to the shape of the blade edge, whether straight or curved. *This tool is not intended for heavy-duty use; do not exceed 30 minutes use in 1 hour.*

SET UP

Rotate Sharpening Cassette into the Grinding position.



BELT	ANGLE GUIDE	EDGE GUIDE	SPEED
GREEN P80	REMOVED	DOWN	GRINDING (2)

STEP 1

Remove the mower blade following manufacturer's instructions; secure blade in bench vise.

STEP 2

Squeeze power switch; grind edge of tool until you are satisfied with the sharpness.

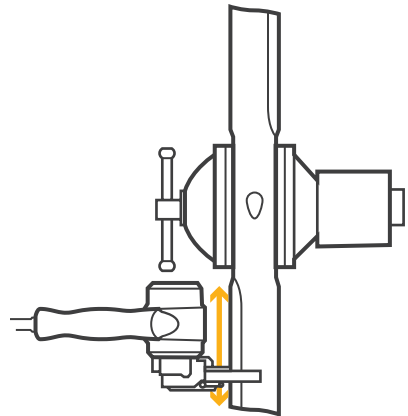

STEP 3

Unclamp blade, rotate 180° and sharpen other side of blade.

NOTE: Remove material evenly to ensure blade remains balanced to manufacturer's specifications.

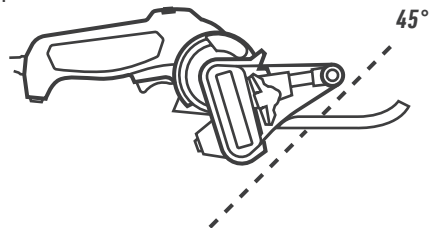

GRINDING, POLISHING, DEBURRING

The Knife & Tool Sharpener is the ideal handheld grinder for small tasks, from deburring to polishing.

- *DEBURR TUBING*
- *GRINDING METAL*
- *GRINDING PLASTIC*
- *SANDING WOOD*
- *AUTOMOTIVE FABRICATION*
- *ANY DETAIL GRINDING TASK*

SET UP

Rotate Sharpening Cassette into the Grinding position.

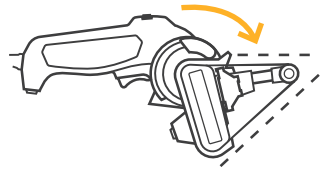

BELT	ANGLE GUIDE	EDGE GUIDE	SPEED
<i>GREEN P80</i>	<i>REMOVED</i>	<i>DOWN</i>	<i>GRINDING (2)</i>

NOTE: This tool is not intended for heavy-duty use; do not exceed 30 minutes use in 1 hour.

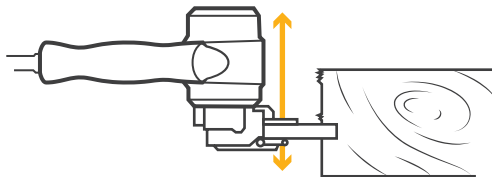
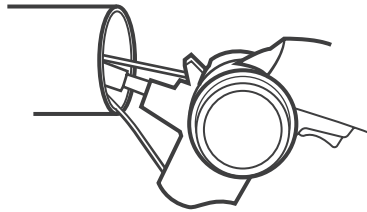



DAREX LLC

210 E Hersey St.
Ashland OR 97520
USA

Phone: 1 (800) 597-6170

Fax: 1 (541) 552-1377

Email: info@darex.com

Visit: Worksharptools.com

WORK SHARP[®] is a registered trademark of Darex, LLC