



SERVICE PARTS LIST

BULLETIN NO.
54-24-2725

SPECIFY CATALOG NO. AND SERIAL NO. WHEN ORDERING PARTS		REVISED BULLETIN	DATE
M18 FUEL™ 1" SDS Plus Rotary Hammer			Apr. 2025
CATALOG NO.	2912-20	SERIAL NO.	L85A and B
		WIRING INSTRUCTION See Page 6	

FIG.	PART NO.	DESCRIPTION OF PART	NO. REQ.
1	42-76-0068	SDS Head Service Kit	1
1-1	42-52-5262	Dust Cap	1
1-2	44-90-0014	C-Ring	2
1-3	42-76-0066	Chuck Sleeve	1
1-4	02-02-0275	7mm Ball	2
1-5	42-36-0191	Ball Plate	1
1-6	40-50-5262	Spring	1
2	31-40-0012	Front Housing Assembly	1
2-1	-----	Front Housing	1
2-2	-----	Spring Seal	1
2-3	-----	Front bushing Spindle	1
2-4	-----	Bushing Spacer Spindle	1
2-5	-----	M2.3 x 6mm ST T-8 Screw	1
2-6	-----	Needle Bearing	1
3	44-90-1001	Locking Plate	1
4	40-50-0870	Spring	1
5	44-10-0062	Selector Knob Assembly	1
6	45-22-0092	SDS Spindle Sleeve Assembly	1

FIG.	PART NO.	DESCRIPTION OF PART	NO. REQ.
28	28-1 28-2 28-3 28-4 28-5 28-6	-----	1
23	-----	-----	1
24	-----	-----	4
16	-----	-----	3
15	-----	-----	1
13	-----	-----	2
11	-----	-----	1
10	-----	-----	2
9-2	-----	-----	1
9-1	-----	-----	1
8	-----	-----	1
7	-----	-----	1
6-1	-----	-----	1
6-2	-----	-----	1
6-3	-----	-----	1
6-4	-----	-----	1
6-5	-----	-----	1
6-6	-----	-----	1
6-7	-----	-----	1
6-8	-----	-----	1
6-9	-----	-----	1
6-10	-----	-----	1
6-11	-----	-----	1
6-12	-----	-----	1
6-13	-----	-----	1
6-14	-----	-----	6
6-15	-----	-----	1
6-16	-----	-----	1
6-17	-----	-----	1
6-18	-----	-----	1
6-19	-----	-----	1
6-20	-----	-----	1
6-21	-----	-----	1
6-22	-----	-----	1
6-23	-----	-----	1
6-24	-----	-----	1
6-25	-----	-----	1
6-26	-----	-----	1
6-27	-----	-----	1
6-28	-----	-----	1
6-29	-----	-----	1
6-30	-----	-----	1
6-31	-----	-----	1
6-32	-----	-----	1
6-33	-----	-----	1
6-34	-----	-----	1
6-35	-----	-----	1
6-36	-----	-----	1
6-37	-----	-----	1
6-38	-----	-----	1
6-39	-----	-----	1
6-40	-----	-----	1
6-41	-----	-----	1
6-42	-----	-----	1
6-43	-----	-----	1
6-44	-----	-----	1
6-45	-----	-----	1
6-46	-----	-----	1
6-47	-----	-----	1
6-48	-----	-----	1
6-49	-----	-----	1
6-50	-----	-----	1
6-51	-----	-----	1
6-52	-----	-----	1
6-53	-----	-----	1
6-54	-----	-----	1
6-55	-----	-----	1
6-56	-----	-----	1
6-57	-----	-----	1
6-58	-----	-----	1
6-59	-----	-----	1
6-60	-----	-----	1
6-61	-----	-----	1
6-62	-----	-----	1
6-63	-----	-----	1
6-64	-----	-----	1
6-65	-----	-----	1
6-66	-----	-----	1
6-67	-----	-----	1
6-68	-----	-----	1
6-69	-----	-----	1
6-70	-----	-----	1
6-71	-----	-----	1
6-72	-----	-----	1
6-73	-----	-----	1
6-74	-----	-----	1
6-75	-----	-----	1
6-76	-----	-----	1
6-77	-----	-----	1
6-78	-----	-----	1
6-79	-----	-----	1
6-80	-----	-----	1
6-81	-----	-----	1
6-82	-----	-----	1
6-83	-----	-----	1
6-84	-----	-----	1
6-85	-----	-----	1
6-86	-----	-----	1
6-87	-----	-----	1
6-88	-----	-----	1
6-89	-----	-----	1
6-90	-----	-----	1
6-91	-----	-----	1
6-92	-----	-----	1
6-93	-----	-----	1
6-94	-----	-----	1
6-95	-----	-----	1
6-96	-----	-----	1
6-97	-----	-----	1
6-98	-----	-----	1
6-99	-----	-----	1
6-100	-----	-----	1

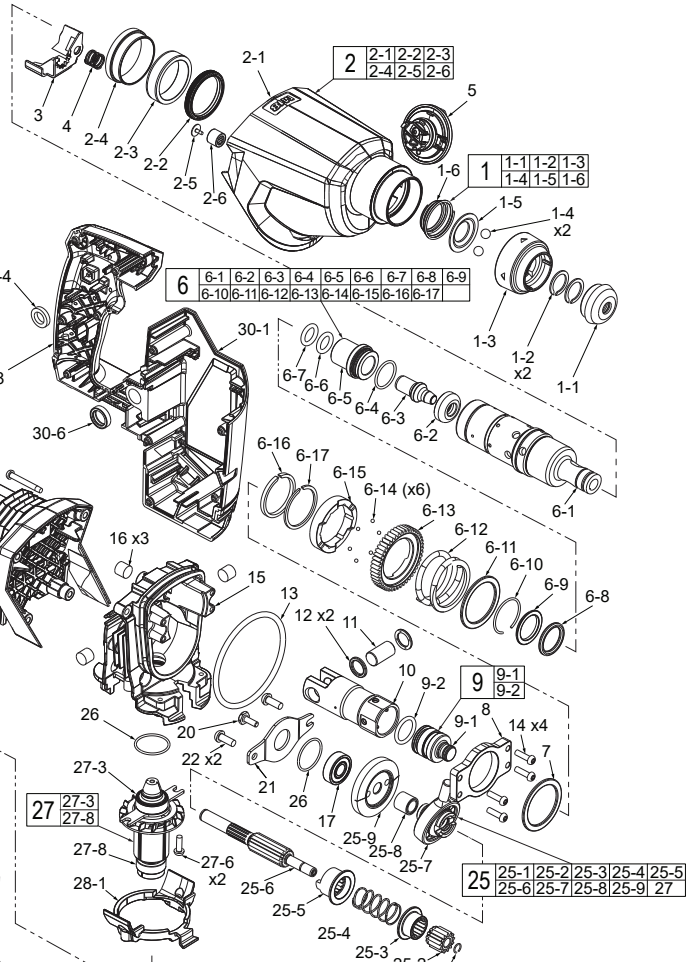

EXAMPLE:
00 0 Component Parts (Small #) Are Included When Ordering The Assembly (Large #).

FIG.	PART NO.	DESCRIPTION OF PART	NO. REQ.
6-1	38-50-0081	Spindle	1
6-2	43-06-0026	Brake Ring	1
6-3	45-08-0042	Anvil	1
6-4	34-40-0192	O-Ring	1
6-5	45-22-0088	Anvil Sleeve	1
6-6	34-40-0193	O-Ring	1
6-7	34-40-0194	Back Pressure Ring	1
6-8	34-40-0197	Bumper Ring	1
6-9	42-76-0067	Washer	1
6-10	44-90-0101	Snap Ring	1
6-11	45-88-0207	Thrust Washer	1
6-12	40-50-0183	M-Clutch Spring	1
6-13	32-75-0028	Gear	1
6-14	02-02-0111	2.5mm Ball	6
6-15	42-70-0138	Clutch Plate	1
6-16	44-90-0102	Retaining Ring	1
6-17	44-90-0103	Snap Ring	1
7	45-88-0208	Washer	1
8	42-36-0126	Bearing	1
9	45-56-0026	Striker / O-Ring Assembly	1
9-1	-----	Striker	1
9-2	34-40-1511	O-Ring	1
10	44-62-0033	Piston	1
11	44-60-0176	Wrist Pin	1
12	44-60-1990	Wrist Pin Washer	2
13	43-44-1375	Gasket	1
14	05-81-1337	M4 x 0.7mm Machine Screw	8
15	31-15-0079	Gearcase	1
16	43-84-0300	Felt Plug	3
17	02-04-0156	Ball Bearing	1
19	45-88-0209	Washer	1
20	05-81-0196	M4 x 12mm Screw	1
21	42-92-0087	Bearing Retainer	1
22	05-78-0032	M5 x 13mm Mach. Screw	2
23	31-44-0238	Rear Housing Assembly	1
24	05-88-1525	M4 ST Screw	1
25	36-92-0013	Wobble Shaft Assembly	4

FIG.	PART NO.	DESCRIPTION OF PART	NO. REQ.
25-1	44-90-1180	C-Ring	1
25-2	32-60-0021	Second Pinion	1
25-3	45-22-0089	Coupler	1
25-4	44-50-0101	Mode Select Spring	1
25-5	45-22-0091	Wobble Bearing Coupler	1
25-6	-----	I-Shaft	1
25-7	36-92-0012	Wobble Bearing	1
25-8	45-36-1826	Spacer	1
25-9	-----	1st Bevel Gear	1
26	34-40-0201	O-Ring	2
27	16-01-0117	Rotor Assembly	1
27-3	-----	Ball Bearing	1
27-6	05-81-0266	M4 x 8mm M Screw w/ Nylock	2
27-8	-----	Ball Bearing	1
28	14-20-0351	PCBA / Motor / Stator Assembly	1
28-1	31-86-0012	Clamp Spacer	1
28-2	-----	Stator	1
28-3	31-50-0066	Motor Housing	1
28-4	06-82-2367	M3 x 1.058 Pan Hd. T-10 Screw	2
28-5	-----	M2 x 0.89 PT Screw	4
29	42-28-2712	Terminal Cover	1
30	31-44-0237	Handle Housing Kit	1
30-1	-----	Housing-Support	1
30-2	-----	Housing-Cover	1
30-4	42-40-7160	Foam Bushing	2
30-5	45-24-0072	Shuttle	1
30-6	44-52-0081	Rubber Cushion	2
30-7	-----	Handle Cover	1
30-8	-----	Handle Support	1
30-9	06-82-1080	M3 ST Screw	11
30-10	-----	Spring	1
31	31-44-0208	Side Handle Assembly	1
32	12-20-0328	Service Nameplate (Not shown)	1
33	42-55-0171	Blow Molded Case (Hammer w/ 2 Batteries)	1
	42-55-0173	Blow Molded Case (Hammer, DDE w/ 2 Batteries)	1

LUBRICATION NOTES: Type GE 00 Urethyn Grease
No. 49-08-5355, 2.8 oz./80g tube

NOTE: The entire contents of the grease tube will not be used. Use a total of approximately .32 oz./9.2g.

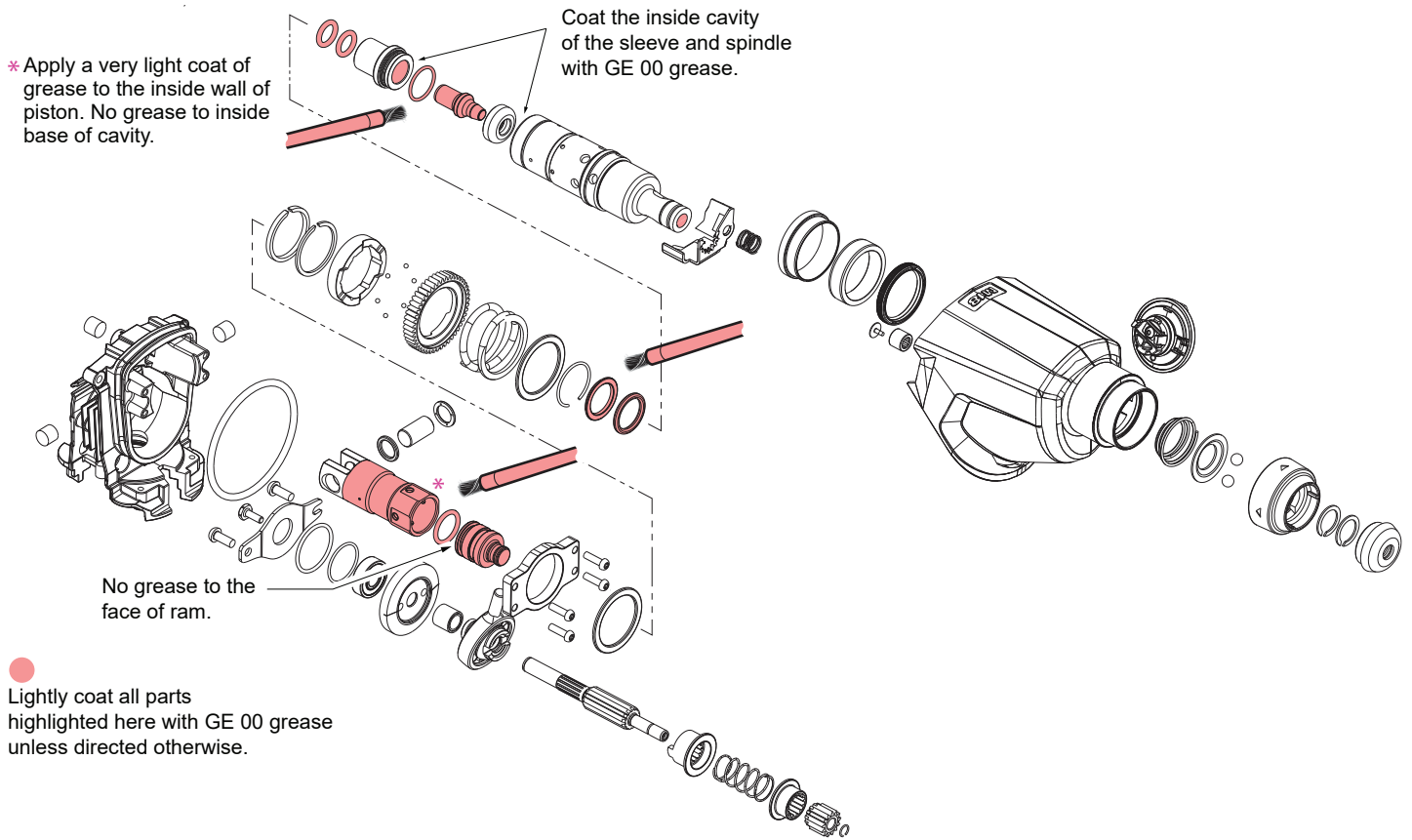

LUBRICATION NOTES: Type 'B118' Grease
No. 45-00-0230,
1.75 oz./50g tube

NOTE: The entire contents of the grease tube will not be used. Use a total of approximately 3.06 oz./86.7g.

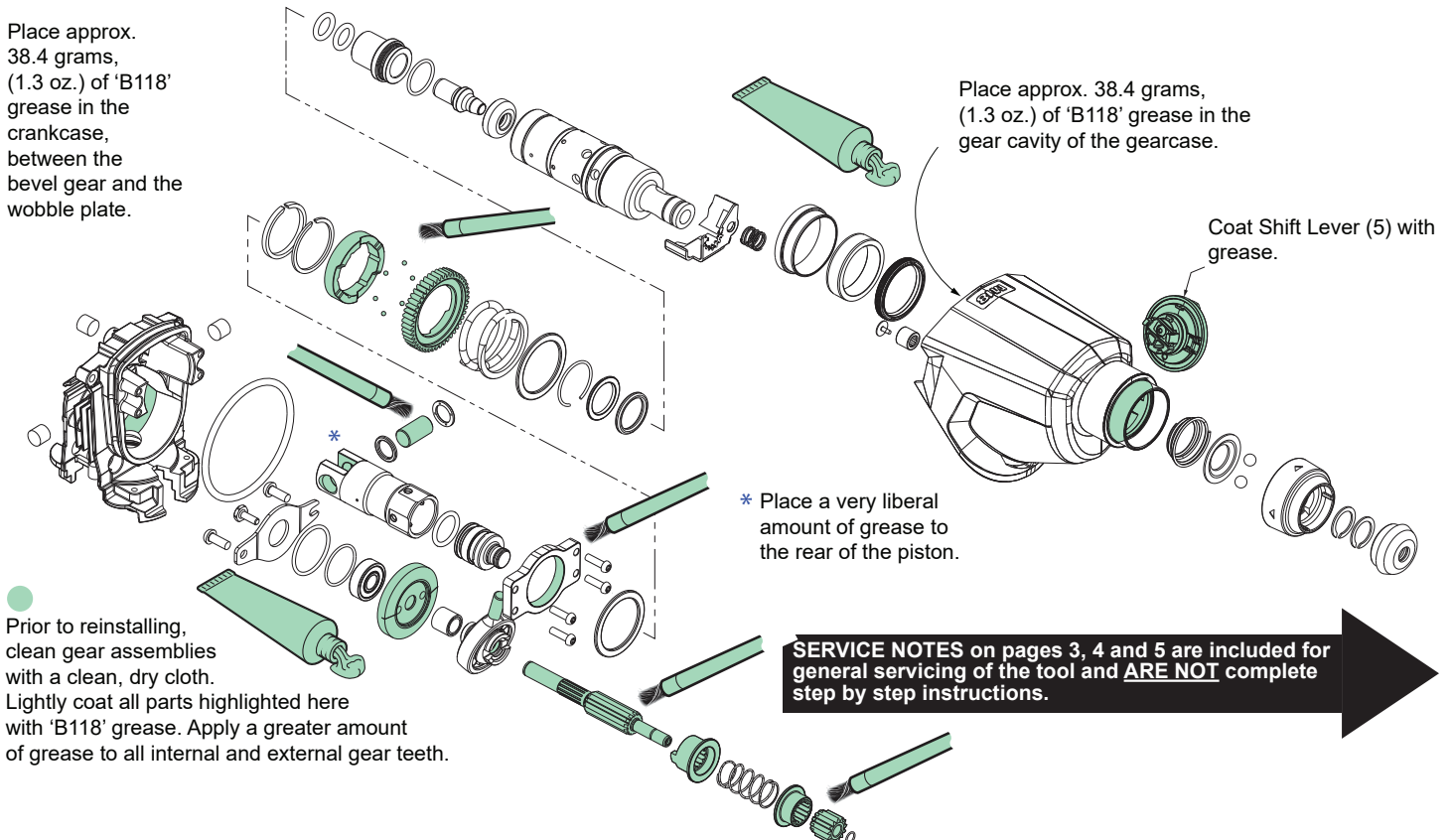

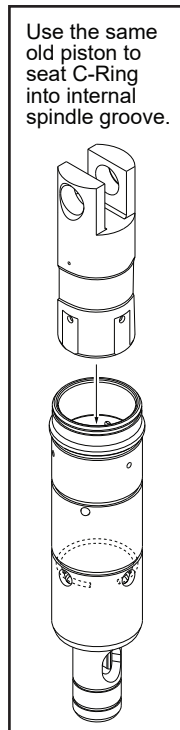
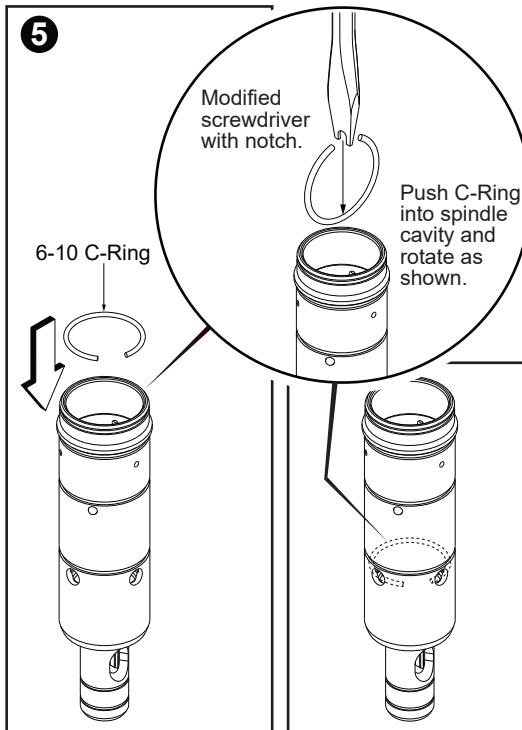
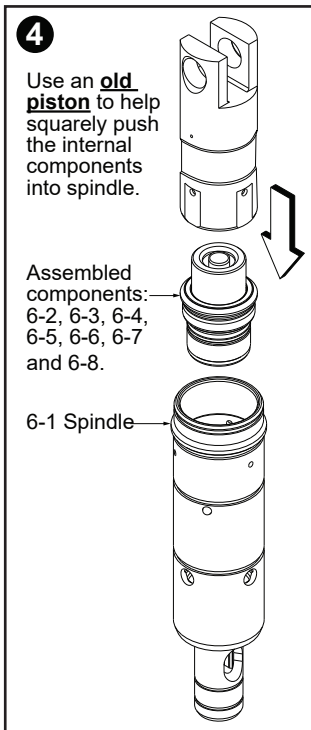
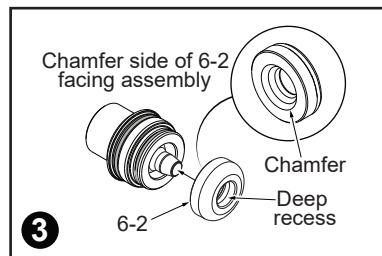
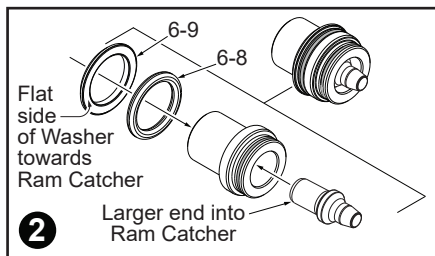
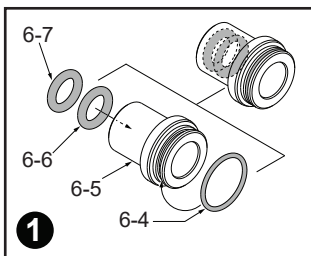

Assembly of internal Spindle components:

1. Lubricate Ram Catcher and O-Rings. Assemble O-Rings onto and into Ram Catcher.
2. Assemble Striker Assembly into Ram Catcher Assembly (large end into Ram Catcher as shown).
3. Place the chamfered end of the Stop Washer over the small end of the Striker.
4. Place the assembled components from step 4 into the cavity of an old piston as shown. Use the old piston as an aid to push the assembled components deep into the Spindle cavity.
5. C-Ring (6-10) will be used to secure the internal components inside the spindle. *It is recommended to modify a flat blade screwdriver by filing or grinding a notch into the blade.* Place the C-Ring upright as shown with the opening of the ring straight up. Use the modified screwdriver to push the C-Ring down into the Spindle cavity. Rotate the C-Ring in the spindle cavity as shown. Place the old piston into the Spindle cavity and tap the piston with a mallet to secure the C-Ring in the groove.

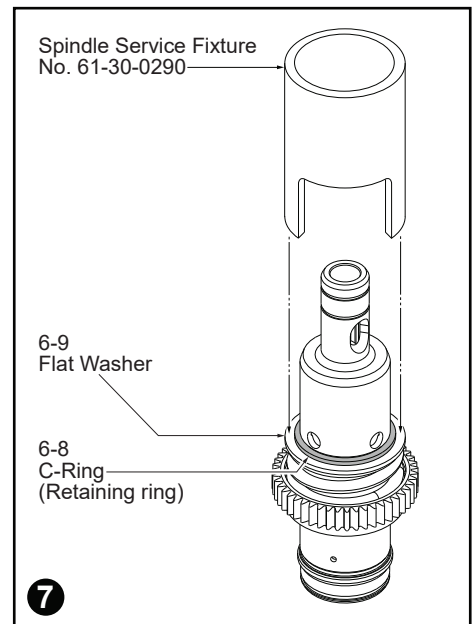
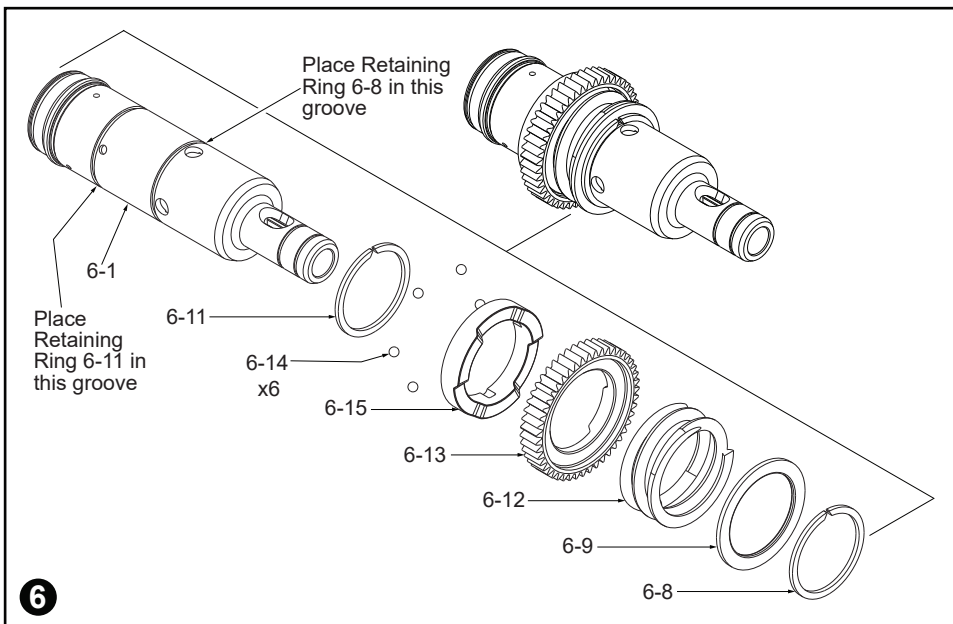

Assembly of external Spindle components:

6. Place C-Ring 6-11 onto Spindle. With the aid of a snap ring pliers, work the C-Ring into the rear most spindle groove and snap into place.

As an aid, put a dab of grease on your finger to pick up and place the six Steel Balls 6-14 into the three small holes on the Spindle just above the previously installed C-Ring.

Lubricate and install the Clutch Plate 6-15 onto the Spindle. Be sure to orient the part as shown and position with the three notches on the back of the plate over the six steel balls.

Lubricate and install the Clutch Gear 6-13. Place the Clutch Spring 6-12 over the Clutch Gear and the Washer 6-9 over the Spring.

Place C-Ring 6-8 onto Spindle. With the aid of a snap ring pliers, work the C-Ring down to the other parts assembled onto spindle.

7. Place Spindle Service Fixture 61-30-0290 over the assembled parts and the spindle. Position so the fixture rests on Flat Washer 6-9. Place the fixture and spindle assembly in an arbor press and carefully compress the Clutch Spring enough to expose the spindle groove for C-Ring 6-8.

While compressed, use a screwdriver to work C-Ring 6-8 into the groove.

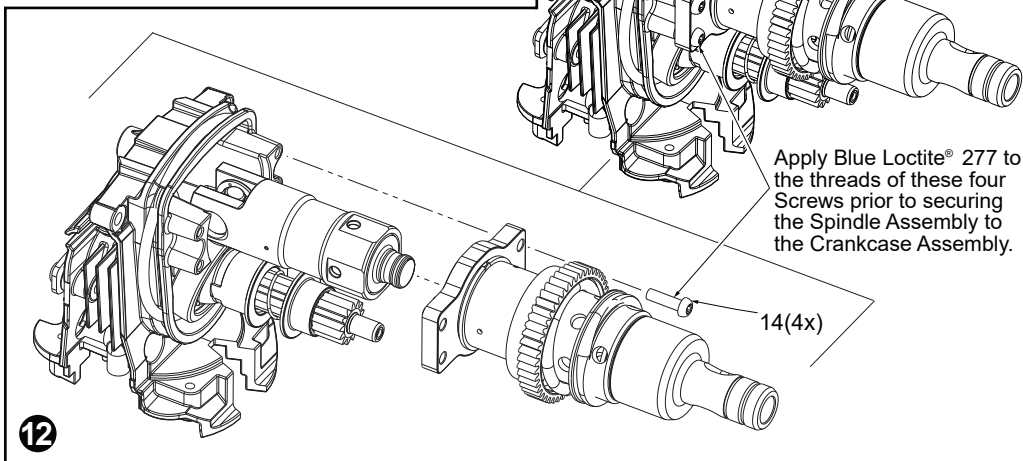
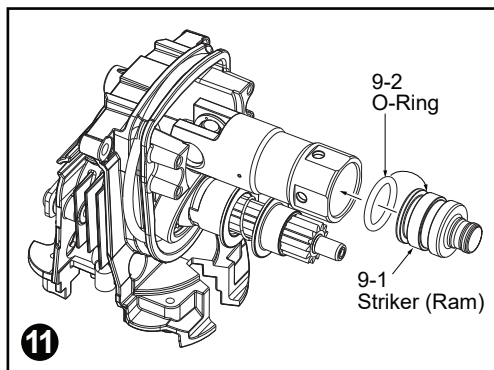
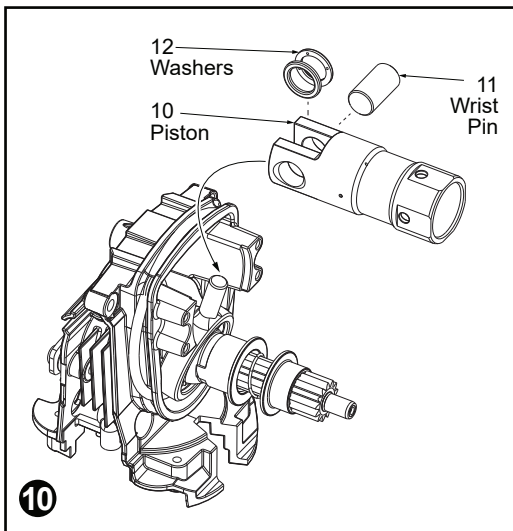
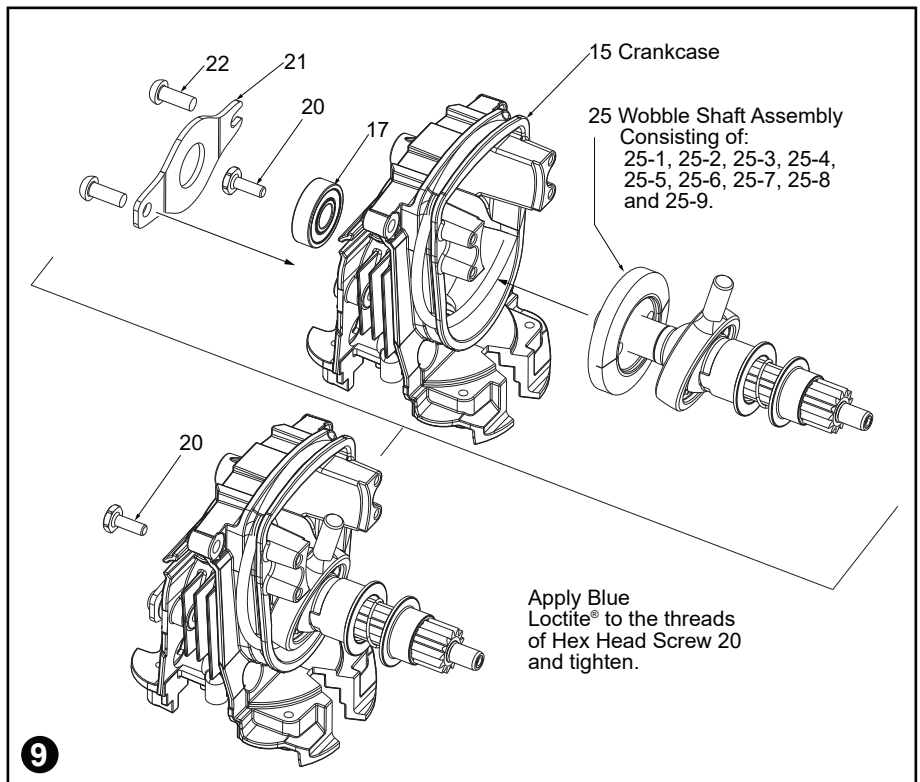
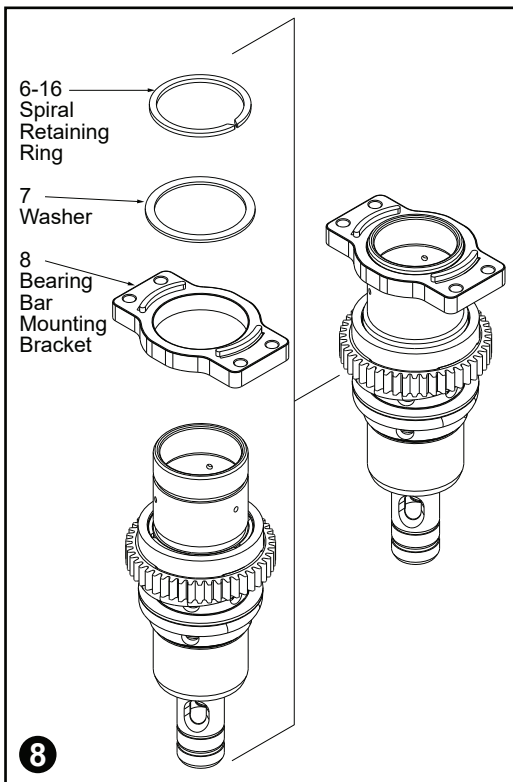

8. The flat side of the Bearing Bar 8 has a rounded recess area that will receive the Spindle. Coat the recess area and place the Spindle Bearing in the recess. Place the two parts onto the Spindle Assembly as shown. Next place the Washer 7 on top of the Bearing Bar and secure with Spiral Retaining Ring 6-16.

Mounting the Spindle Assembly onto the Crankcase Assembly

9. Lubricate the inside cavity of the Crankcase 15 with grease. Place Wobble Shaft Assembly 25 into Crankcase Assembly as shown. Use 9mm Hex Head Screw 20 to secure Wobble Shaft Assembly to Crank-case Assembly. **NOTE:** Prior to installing screw, place a few drops of Blue Loctite® thread locking sealant to the threads and tighten. Use a 9mm socket and tighten Hex Head Screw to 15-20 lb-in (18-23 kgf-cm).
10. Place Washers 12 and Wrist Pin 11 into rear area of Piston 10. While holding those parts in place, be sure the Washers are separated, one on each side of the hole in the Wrist Pin. Connect the Piston Assembly to the Wobble Shaft Assembly by sliding the hole on the Wrist Pin over the arm on the wobble bearing.
11. Lubricate O-Ring 9-2 and Striker (Ram) 9-1. Be sure not to have any lubrication on the rear (flat side) of Striker. Place O-Ring onto Striker 9-1. Insert assembled parts into Piston 10 as shown.
12. Mount the Spindle Assembly onto The Crankcase Assembly by inserting the Piston into the Spindle. Use four Screws to secure the Spindle Assembly to the Crankcase Assembly. **NOTE:** Prior to installing screws, place a few drops of Blue Loctite® thread locking sealant to the threads.

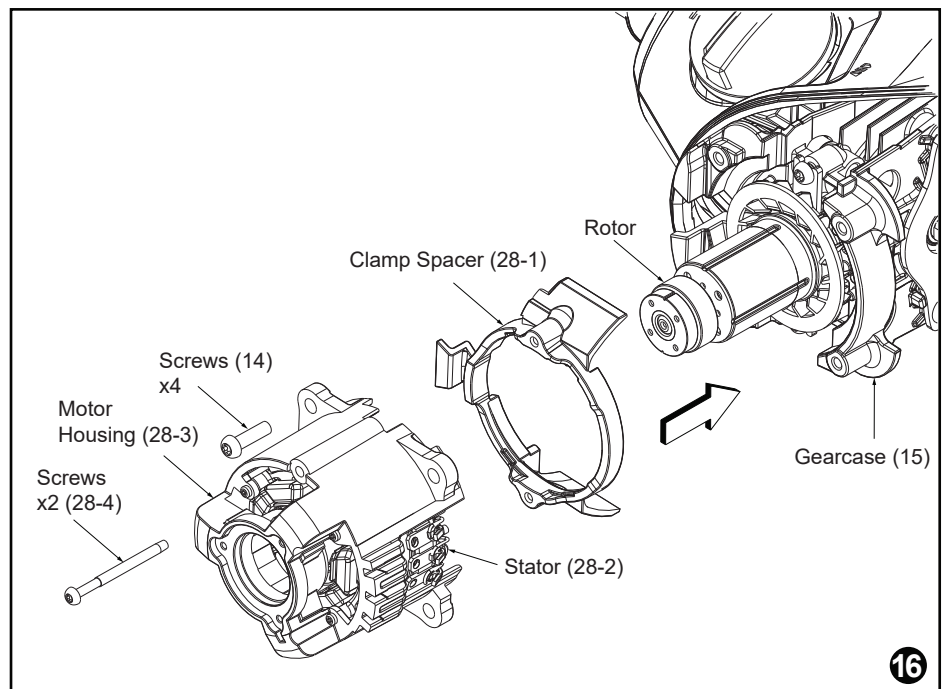
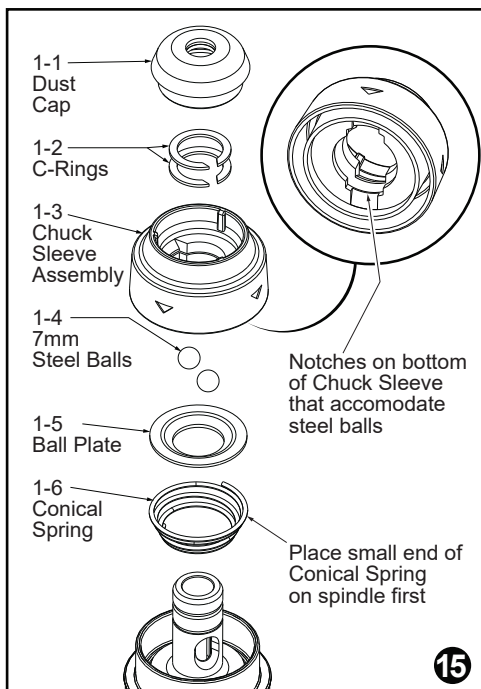
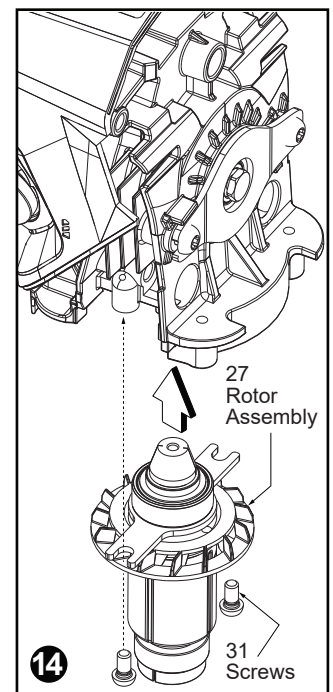
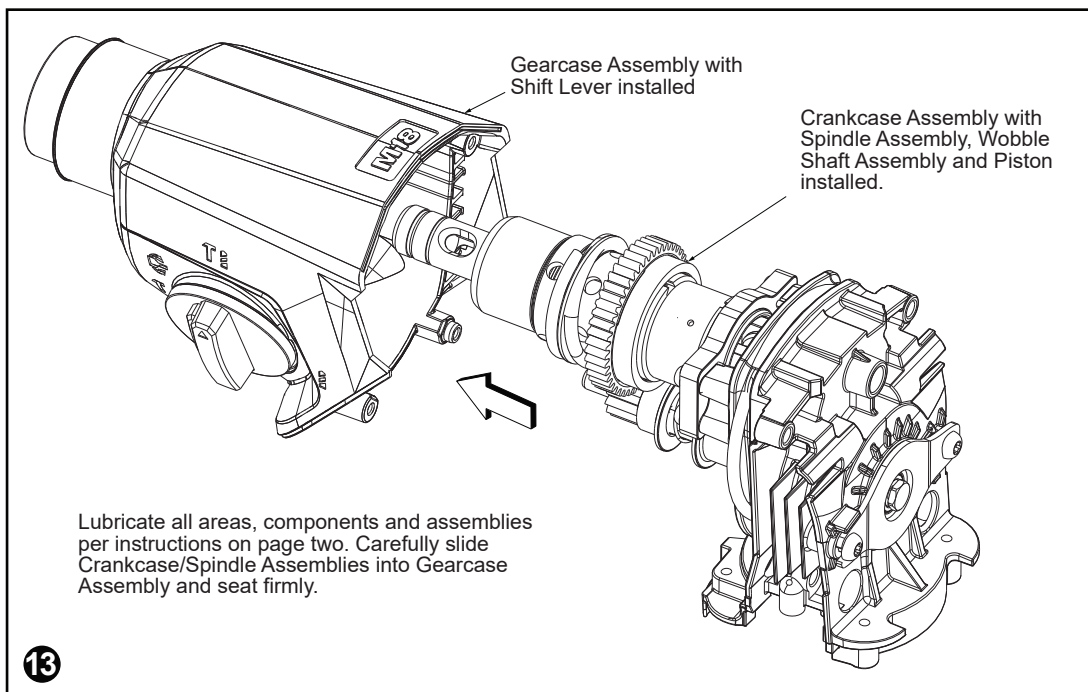

13. Install the Crankcase / Spindle Assembly into the Gearcase Assembly while following the lubrication instructions on page two.

14. Install the Rotor Assembly 27 into the bottom of the Crankcase. To prevent unevenness, start one screw 31 but do not tighten. Install the other screw and tighten both to 21-26 lb-in (25-30 kgf-cm).

15. Install the front components onto the Spindle.

Place the small end of the Conical Spring 1-6 onto the spindle first.

Place the Ball Plate 1-5 over the spring (flat side up).

Compress the Conical Spring to install the two Steel Balls 1-4.

Place the SDS Head Service Kit 1 onto the Spindle over the Steel Balls. Notice the notches in the sleeve that correspond to the Steel Balls.

Install one of the C-Rings onto the bottom most groove on the front of the Spindle. Be sure the C-Ring is seated properly in that groove. Check the Chuck Sleeve Assembly for proper functionality.

15. Continued...
Install the second C-Ring onto the front most groove of the Spindle. Be sure the C-Ring is seated properly in that groove.

Place the Dust Cap 1-1 over the front of the Spindle and that last C-Ring. Once again check that the SDS Head Service Kit is functioning properly.

16. Place Stator 28-2 in Motor Housing 28-3.

Place the Clamp Spacer 28-1 onto Motor Housing 28-3.

Place two Screws 28-4 through holes on Motor Housing 28-3 and fasten to Clamp Spacer 28-1.

Place all four Screws 14 onto the Motor Housing Cover and tighten in Gearcase 15 to 30-34 lb-in (35-40 kgf-cm).

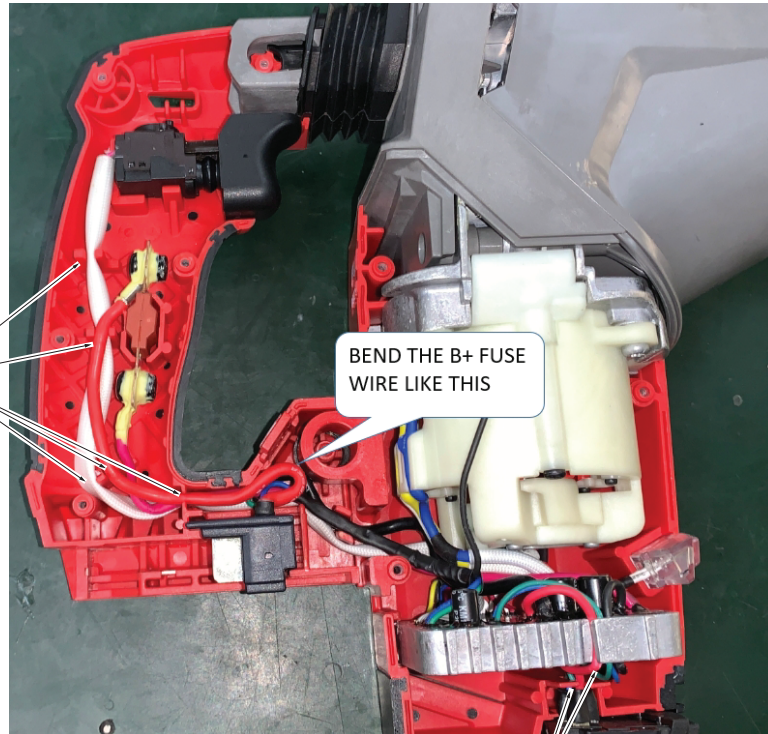
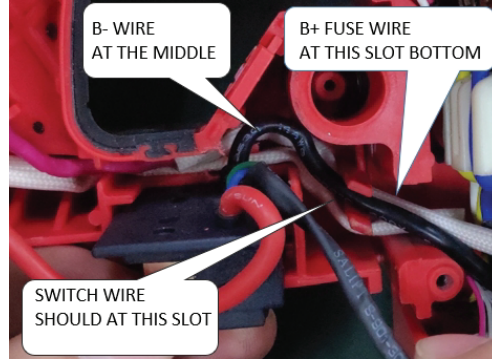
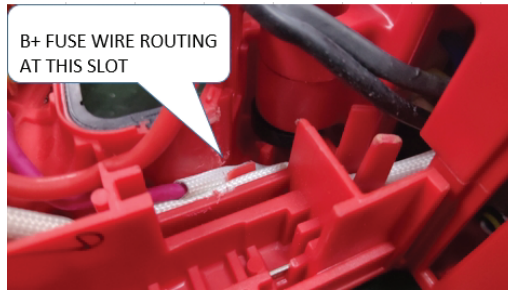

Wire traps or channels

BEND THE B+ FUSE WIRE LIKE THIS

Ensure wires are in channel.

●14-46-0196

Rotary Hammer Service Kit

1-1	42-52-5262	Dust Cap	1
1-2	44-90-0014	C-Ring	2
1-3	42-76-0066	Chuck Sleeve	1
6-4	34-40-0192	C-Ring	1
6-6	34-40-0193	O-Ring	1
6-7	34-40-0194	Back Pressure Ring	1
6-8	34-40-0197	Bumper Ring	1
6-10	44-90-0101	Snap Ring	1
6-14	02-02-0111	2.5mm Ball	6
6-16	44-90-0102	Retaining Ring	1
6-17	44-90-0103	Snap Ring	1
9-2	34-40-1511	O-Ring	1
12	44-60-1990	Wrist Pin Washer	2
13	43-44-1375	Gasket	1
14	05-81-1337	M4 x 0.7mm Screw	8
16	43-84-0300	Felt Plug	3
20	05-81-0196	M4 x 12mm Screw	1
22	05-78-0032	M5 x 13mm Screw	2
24	05-88-1525	M4 ST Screw	4
25-1	44-90-1180	C-Ring	1
26	34-40-0201	O-Ring	2
27-6	05-81-0266	M4 x 8mm M Screw	2
30-4	42-40-7160	Foam Bushing	2
30-6	44-52-0081	Rubber Cushion	2
30-9	06-82-1080	M3 ST Screw	11
	49-08-5355	GE 00 Grease	
		2.8 oz	1
	45-00-0230	B118 Grease	
		1.75 oz	2

SCREW TORQUE SPECIFICATIONS

FIG.	PART NO.	WHERE USED	SEAT TORQUE	
			(kgf-cm)	(lb-in)
2-5	-----	Front Housing Assembly	3.5	0.5
14	05-81-1337	Bearing Bar Mounting Bracket	12	10
20	-----	Gearcase Assembly	27	23
22	05-78-0032	Bearing Retainer	50	43
24	05-88-1525	Rear Housing Assembly	28	24
27-6	05-81-0266	Rotor Assembly	18	16
28-4	06-82-2367	Motor Housing	10	8
28-5	-----	PCBA Assembly	3	1
28-6	06-82-0196	PCBA	4	2
30-9	06-82-1080	Housing / Handle Cover	10	8