

USE AND CARE GUIDE

650 LB POLY DUMP CART

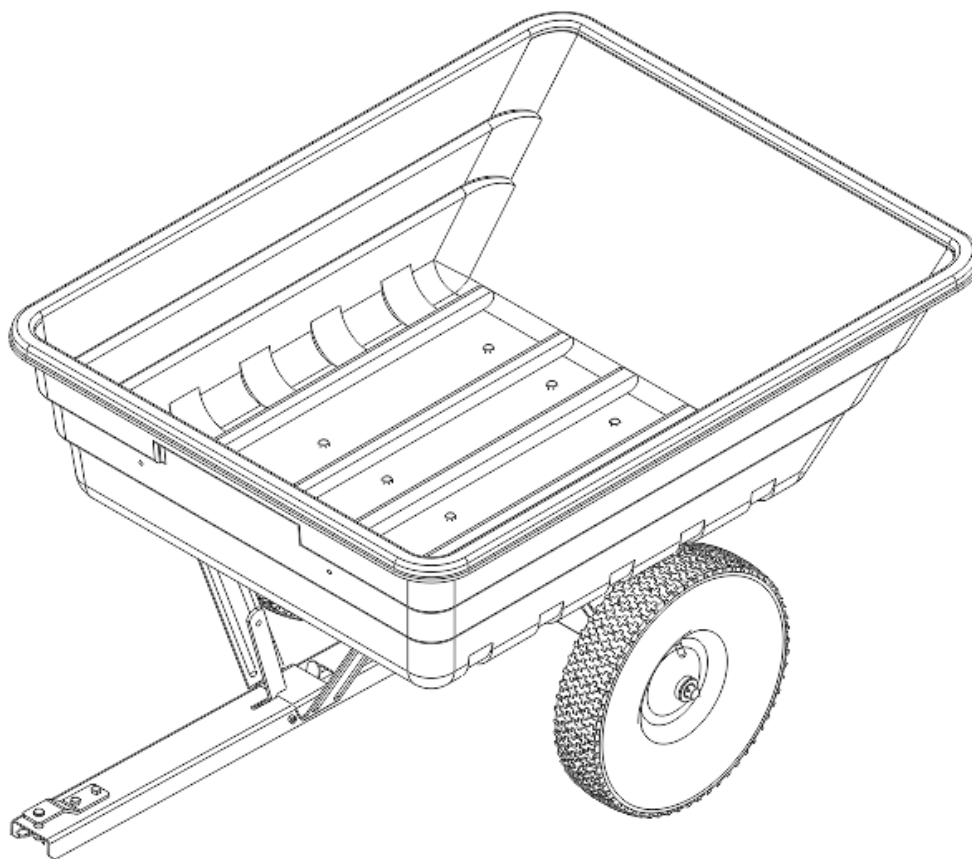

Questions, problems, missing parts? Before returning to the store,
call Precision Customer Service
8 a.m. – 5 p.m., CST, Monday-Friday

1-800-225-5891

PRECISIONPRODINC.COM

4886-1 Rev 8/20

THANK YOU

We appreciate the trust and confidence you have placed in Precision through the purchase of this 650 lb Poly Dump Cart. We strive to continually create quality products designed to enhance your home. Visit us online to see our full line of products available for your home improvement needs. Thank you for choosing Precision!

Table of Contents

| | |
|-----------------------------|---|
| Table of Contents..... | 2 |
| Safety Information..... | 2 |
| SAFETY INSTRUCTIONS..... | 2 |
| Pre-Assembly | 3 |
| Planning Installation | 3 |
| Tools required..... | 3 |
| Hardware Included..... | 3 |
| Package Contents | 4 |
| Assembly..... | 5 |
| Assembly (continued) | 6 |
| Service Parts..... | 7 |
| 650 lb Poly Dump Cart..... | 7 |

| | |
|--|---|
| Service Parts (continued)..... | 8 |
| 650 lb Poly Dump Cart..... | 8 |
| Troubleshooting..... | 8 |
| Maintenance..... | 8 |
| Storage..... | 8 |
| Warranty | 9 |
| 12 month limited warranty for accessories..... | 9 |
| What is Covered..... | 9 |
| What is Not Covered | 9 |

Safety Information

SAFETY INSTRUCTIONS

- Tractor braking and stability may be affected with the attachment of this unit. Be aware of changing conditions on slopes. Refer to safety rules in your tractor owner's manual concerning safe operation on slopes. **STAY OFF STEEP SLOPES!**
- Keep adults, children, and animals at a safe distance.
- Never allow children to operate the towing vehicle. Do not allow adults to operate the vehicle without having read the owner's manual or receiving proper instruction.
- Always wear substantial footwear. Do not wear loose fitting clothing that may get caught in moving parts.
- Always begin with the transmission in first (low) gear and the engine at low speed, and gradually increase speed as conditions permit.
- This equipment should be operated at reduced speed(s) on rough terrain and on hillsides to prevent tipping or loss of control.
- Stay alert for holes in the terrain and other hidden hazards.
- Always operate up and down a slope, never across the face of a slope.
- The tractor and attachment should be stopped and inspected for damage after striking a foreign object. Any damage should be repaired before restarting and operating the equipment.
- Keep the tractor and attachment in good operating condition and keep safety devices in place.
- Keep all nuts, bolts, and screws tight to be sure the equipment is in safe working condition.



DANGER: STAY OFF STEEP SLOPES!



DANGER: Do not allow anyone to ride or sit on the tow behind equipment during operation.



WARNING: Do not exceed maximum towing speed of 4 miles per hour.



WARNING: Do not operate close to creeks, ditches, or public highways.



IMPORTANT: Read and understand your tractor owner's manual and safety rules. Know how to operate your tractor before using any attachment.



IMPORTANT: Maximum carrying capacity is 650 lbs.

Pre-Assembly

PLANNING INSTALLATION

Remove the Hardware from the Hardware Sack and verify that all the Hardware shown is included.

TOOLS REQUIRED

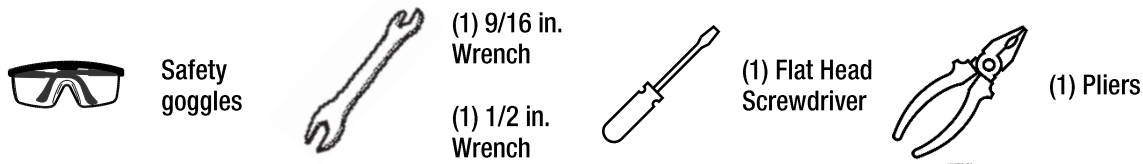

HARDWARE INCLUDED

 **NOTE:** Hardware not shown to actual size.

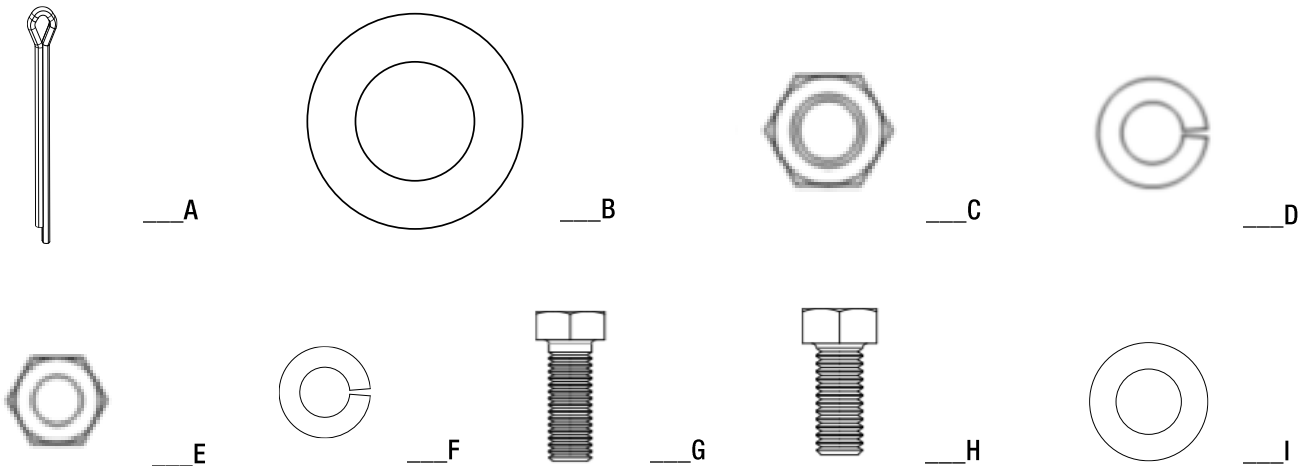

| Part | Description | Quantity |
|------|--------------------------------|----------|
| A | 1/8 in. x 1-1/4 in. Cotter Pin | 2 |
| B | 3/4 in. Flat Washer | 4 |
| C | 3/8 in. Hex Head Nut | 8 |
| D | 3/8 in. Lock Washer | 8 |
| E | 5/16 in. Hex Head Nut | 4 |
| F | 5/16 in. Lock Washer | 4 |
| G | 3/8 in. x 1 in. Hex Head Bolt | 8 |
| H | 5/16 in. x 1 in. Hex Head Bolt | 4 |
| I | 3/8 in. Flat Washer | 8 |
| J | 5/16 in. Flat Washer | 4 |
| K | 1 in. x 1 in. Spacer | 2 |



Pre-Assembly (Continued)

PACKAGE CONTENTS



__L

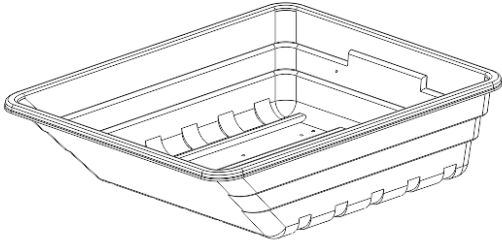

__M

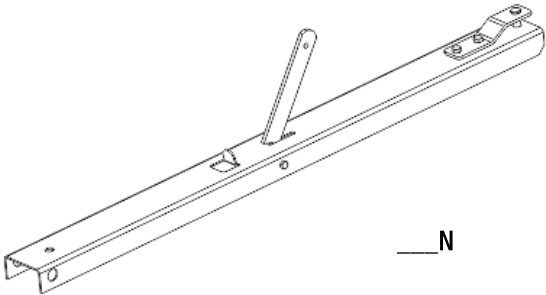

__N

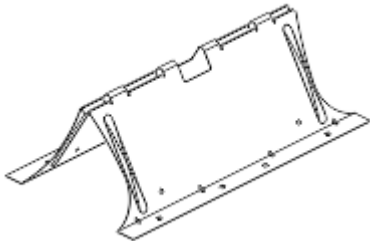

__O



__P

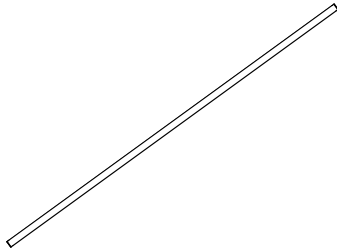

__Q

| Part | Description | Quantity |
|------|-------------------|----------|
| L | **Wheel | 2 |
| M | *Cart Body | 1 |
| N | Tow Bar Assembly | 1 |
| O | Under Carriage | 1 |
| P | Pedestal | 1 |
| Q | Axle | 1 |
| R | Reinforcing Strip | 2 |



__R

****Tread pattern on tires may vary.**

***Body Design may vary.**

Assembly

1 Under Carriage Assembly

- Place a Reinforcing Strip (R) on the left and right side of the Undercarriage (O) and attach to the bottom of the Cart Body (M) using 3/8 in. x 1 in. Hex Head Bolts (G), 3/8 in. Flat Washers (I), 3/8 in. Lock Washers (D) and 3/8 in. Hex Head Nuts (C).

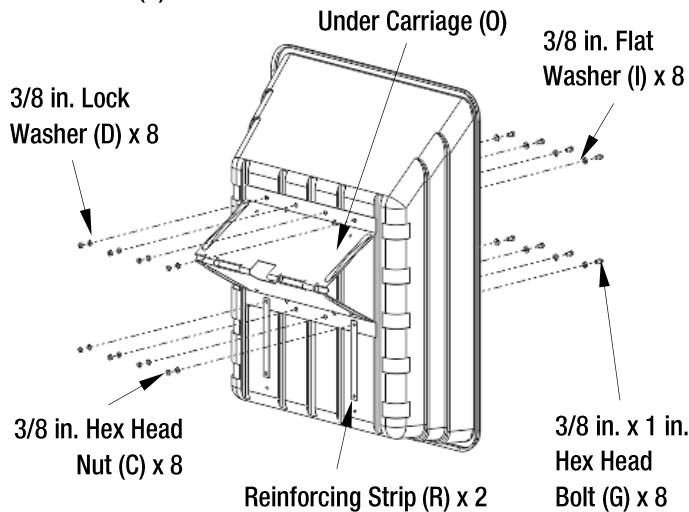

2 Pedestal Assembly

- Attach the Pedestal (P) to the Cart Body (M) using 5/16 in. x 1 in. Hex Head Bolts (H), 5/16 in. Flat Washers (J), 5/16 in. Lock Washers (F) and 5/16 in. Hex Head Nuts (E).

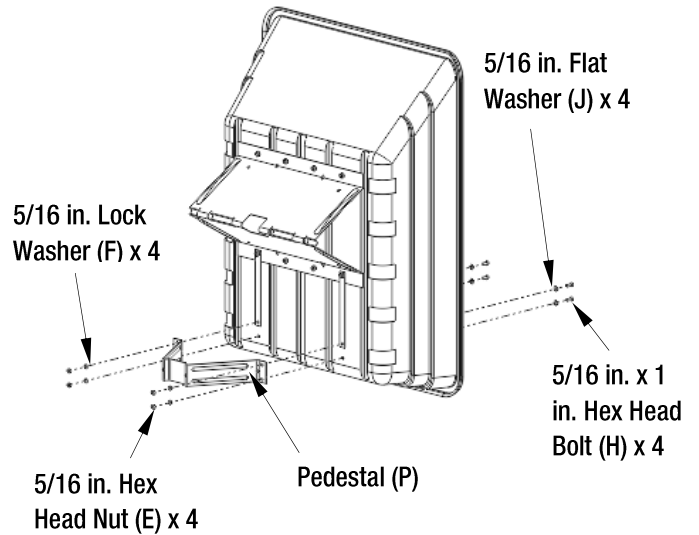

3 Tow Bar Assembly

- Place the Cart Body (M) in a flat position with the Under Carriage (O) and the Pedestal (P) face up.
- Slide the Axle (Q) halfway through the Under Carriage (O).
- Place the Tow Bar Assembly (N) into the center slot of the Under Carriage (O).
- Lock the Latch into the Pedestal (P) and slide the Axle (Q) through the holes in the Tow Bar Assembly (N).
- Slide the Axle (Q) the rest of the way through the Under Carriage (O).

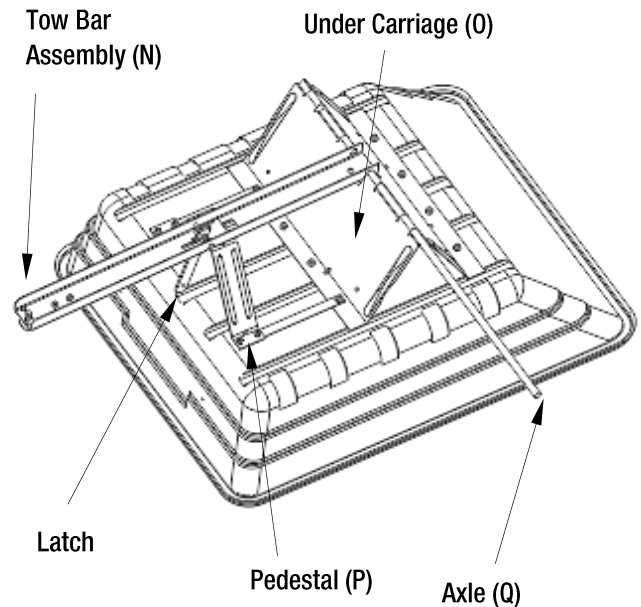

Assembly

4 Wheel Assembly

- Place a 3/4 in. Flat Washer (B), a Spacer (K), a 3/4 in. Flat Washer (B) onto the Axle (Q) up against the Under Carriage (O).
- Next place the Wheel (L) onto the Axle (Q).
- Then place a 3/4 in. Flat Washer (B) onto the Axle (Q) up against the Wheel (L).
- Secure the Wheel (L) by inserting a 1/8 in. x 1-1/4 in. Cotter Pin (A) through the hole at the end of the Axle (Q) and spreading the legs of the 1/8 in. x 1-1/4 in. Cotter Pin (A) outward.
- Repeat for the other side.

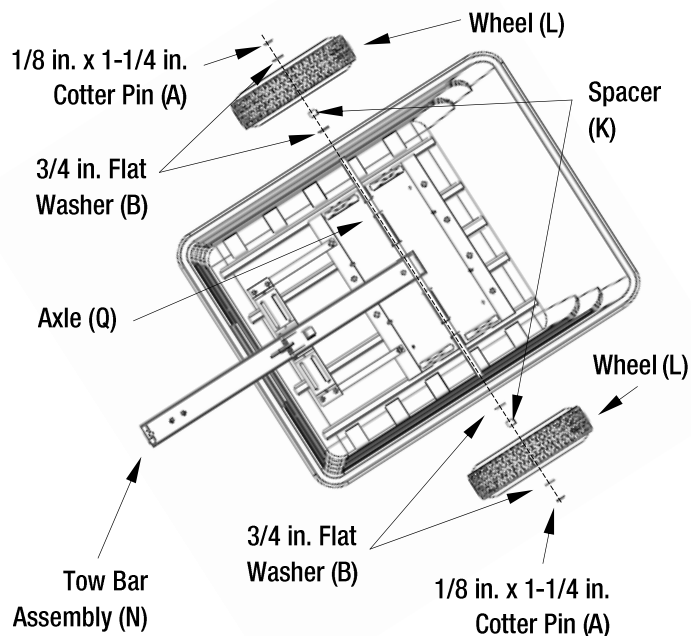

5 Tractor Hitch Assembly

- Place the Cart in the upright position. .
- To attach the Tow Bar to the Hitch of the Tractor remove the 1/2 in. x 1-3/4 in. Clevis Pin and #14 Hitch Pin Clip. Line up the holes in the Clevis with the hole in the Tractor Hitch and secure using the 1/2 in. x 1-3/4 in. Clevis Pin and #14 Hitch Pin Clip.

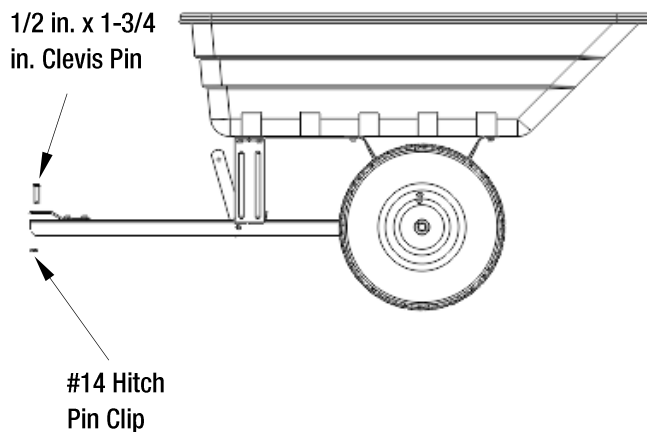

Service Parts

650 LB POLY DUMP CART

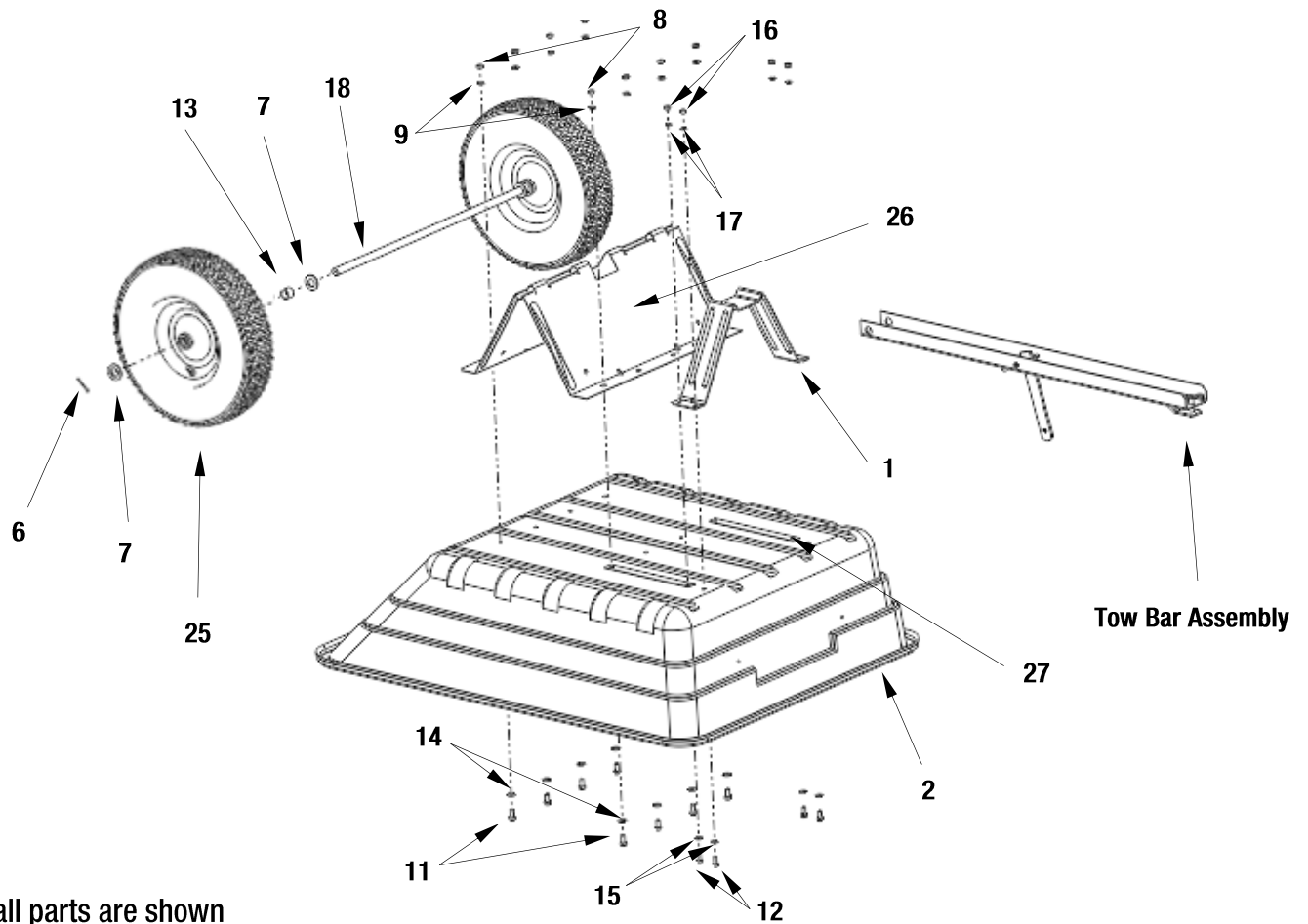
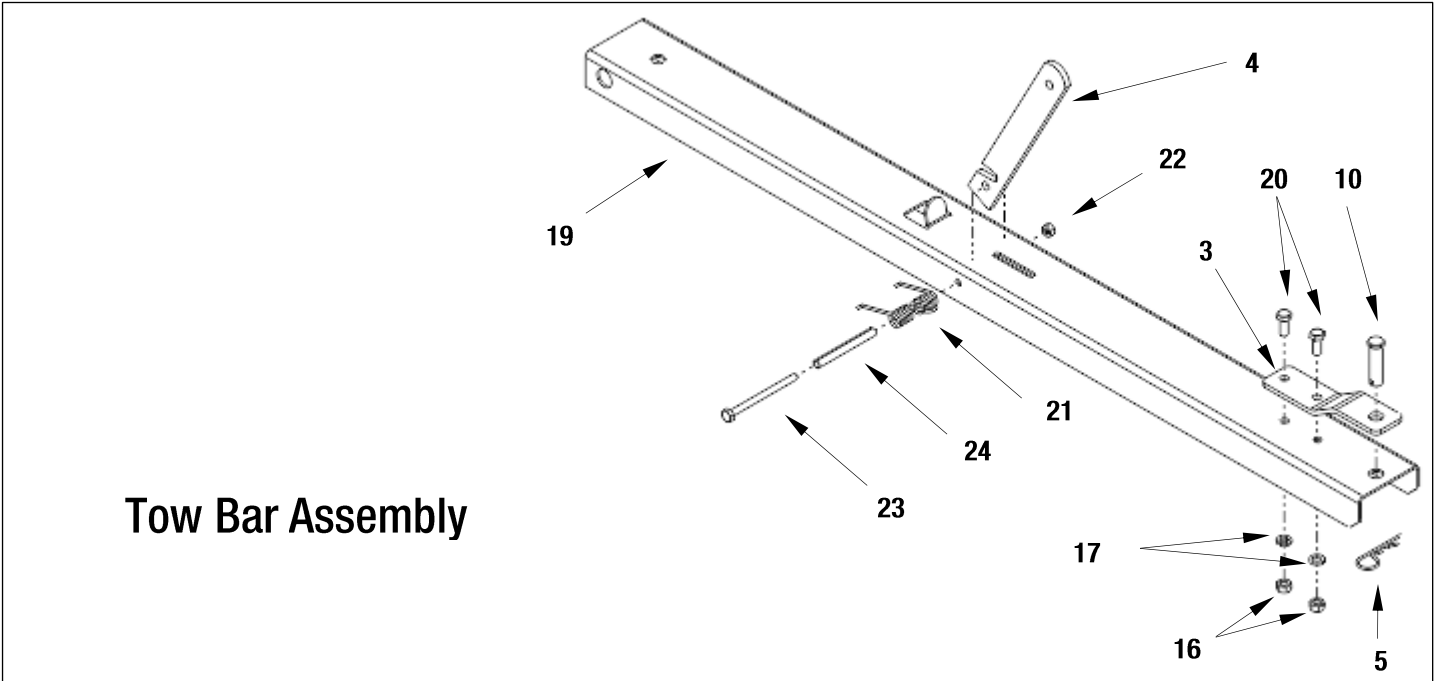

**Not all parts are shown

Service Parts (continued)

650 LB POLY DUMP CART

| Ref # | Part # | Description | Qty |
|-------|--------|--------------------------------|-----|
| 1 | 4630R | PEDESTAL | 1 |
| 2 | 4888 | BODY | 1 |
| 3 | 1243P | CLEVIS | 1 |
| 4 | 1265P | LATCH HANDLE | 1 |
| 5 | 1042 | #14 HITCH PIN CLIP | 1 |
| 6 | 1262 | 1/8 IN. X 1-1/4 IN. COTTER PIN | 2 |
| 7 | 1264 | 3/4 IN. FLAT WASHER | 4 |
| 8 | 1273 | 3/8 IN. HEX HEAD NUT | 8 |
| 9 | 1274 | 3/8 IN. LOCK WASHER | 8 |
| 10 | 1840 | 1/2 IN. X 1-3/4 IN. CLEVIS PIN | 1 |
| 11 | 1974 | 3/8 IN. X 1 IN. HEX HEAD BOLT | 8 |
| 12 | 3738 | 5/16 IN. X 1 IN. HEX HEAD BOLT | 4 |
| 13 | 4899-1 | 1 IN. X 1 IN. SPACER | 2 |
| 14 | 1278 | 3/8 IN. FLAT WASHER | 8 |

| Ref # | Part # | Description | Qty |
|-------|--------|------------------------------------|-----|
| 15 | 1044 | 5/16 IN. FLAT WASHER | 4 |
| 16 | 1275 | 5/16 IN. HEX HEAD NUT | 6 |
| 17 | 1276 | 5/16 IN. LOCK WASHER | 8 |
| 18 | 1252 | AXLE | 1 |
| 19 | 4631R | TOW BAR | 1 |
| 20 | 1586 | 5/16 IN. X 3/4 IN. TRUSS HEAD BOLT | 2 |
| 21 | 4497 | SPRING | 1 |
| 22 | 1250 | 1/4 IN. THIN NYLOCK NUT | 1 |
| 23 | 1645 | 1/4 IN. X 3-1/2 IN. HEX HEAD BOLT | 1 |
| 24 | 4468 | 1/4 IN. X 2-3/4 IN. SPACER | 1 |
| 25 | 4568C | WHEEL | 2 |
| 26 | 4708R | UNDER CARRIAGE | 1 |
| 27 | 4892TB | REINFORCING STRIP | 2 |

Troubleshooting

| Issue | Cause | Solution |
|---------------------------------|------------------------|---|
| The Wheels skid when operating. | The Wheels are jammed. | Check for obstructions or damage to the Wheels. |

Maintenance

- Empty the Cart after each use. Do not store the Cart with material left in the Cart.
- Wash the Cart thoroughly and wipe dry.
- Lubricate all moving parts.

Storage

- Rinse the inside of the body and the exterior of the Cart.
- Store in a clean, dry area.

Warranty

12 MONTH LIMITED WARRANTY FOR ACCESSORIES

WHAT IS COVERED

The limited warranty set forth below is given by Precision Products, Incorporated with respect to new merchandise purchased and used in the United States, its possessions and territories and Canada.

The manufacturer warrants the product(s) listed against defects in material and workmanship, and will at our option, repair or replace, free of charge, any part found to be defective in materials or workmanship. This limited warranty shall only apply if this product has been assembled, operated, and maintained in accordance with the owner's manual furnished with the product, and has not been subject to misuse, abuse, neglect, accident, improper maintenance, alteration, vandalism, theft, fire, water, or damage because of other peril or natural disaster.

Normal wear parts or components thereof are subject to separate terms as follows: All normal wear parts or component failures will be covered on the product for a period of one year. Parts found to be defective within the warranty period will be replaced at our expense. Our obligation under this warranty is expressly limited to the replacement or repair, at our option, of parts found to be defective in material and workmanship.

WHAT IS NOT COVERED

This limited warranty does not provide coverage in the following cases:

1. Routine maintenance items such as lubricants and filters.
2. Normal deterioration of the exterior finish due to use or exposure.
3. Transportation and/or labor charges.

No implied warranty, including any implied warranty of merchantability of fitness for a particular purpose, applies after the applicable period of express written warranty above as to the part as identified below. No other expressed warranty, whether written or oral, except as mentioned above, given by any person or entity, including a dealer or retailer, with respect to any product, shall bind the manufacturer during the period of the warranty, the exclusive remedy is repair or replacement of the product as set forth above. The provisions as set forth in this warranty provide the sole and exclusive remedy arising from the purchase.

The manufacturer will not be liable for incidental or consequential loss or damage including, without limitation, expenses incurred for substitute or replacement lawn care services, or for rental expenses to temporarily replace a warranted product.

Some states and/or territories do not allow the exclusion or limitation of incidental or consequential damages, or limitations on how long an implied warranty lasts, so the above exclusions or limitations may not apply to you.

During the warranty period, the exclusive remedy is replacement of the part. In no event shall recovery of any kind be greater than the amount of the purchase price of the product sold. Alteration of safety features of the product shall void this warranty. You assume the risk and liability for loss, damage, or injury to you and your property and/or to others and their property arising out of the misuse or inability to use this product.

This limited warranty shall not extend to anyone other than the original purchaser or to the person for whom it was purchased as a gift.

Warranty Application

This limited warranty gives you specific legal rights, and you may also have other rights which vary from state to state and/or province to province.

Warranty Period

The warranty period stated below begins with the date appearing on the Proof of Purchase. Without the proof of purchase, the warranty period begins from the date of manufacture, determined by the date code on the box.

Contact the Customer Service Team at 1-800-225-5891
