

BNR1839 Drywall Sanding Machine

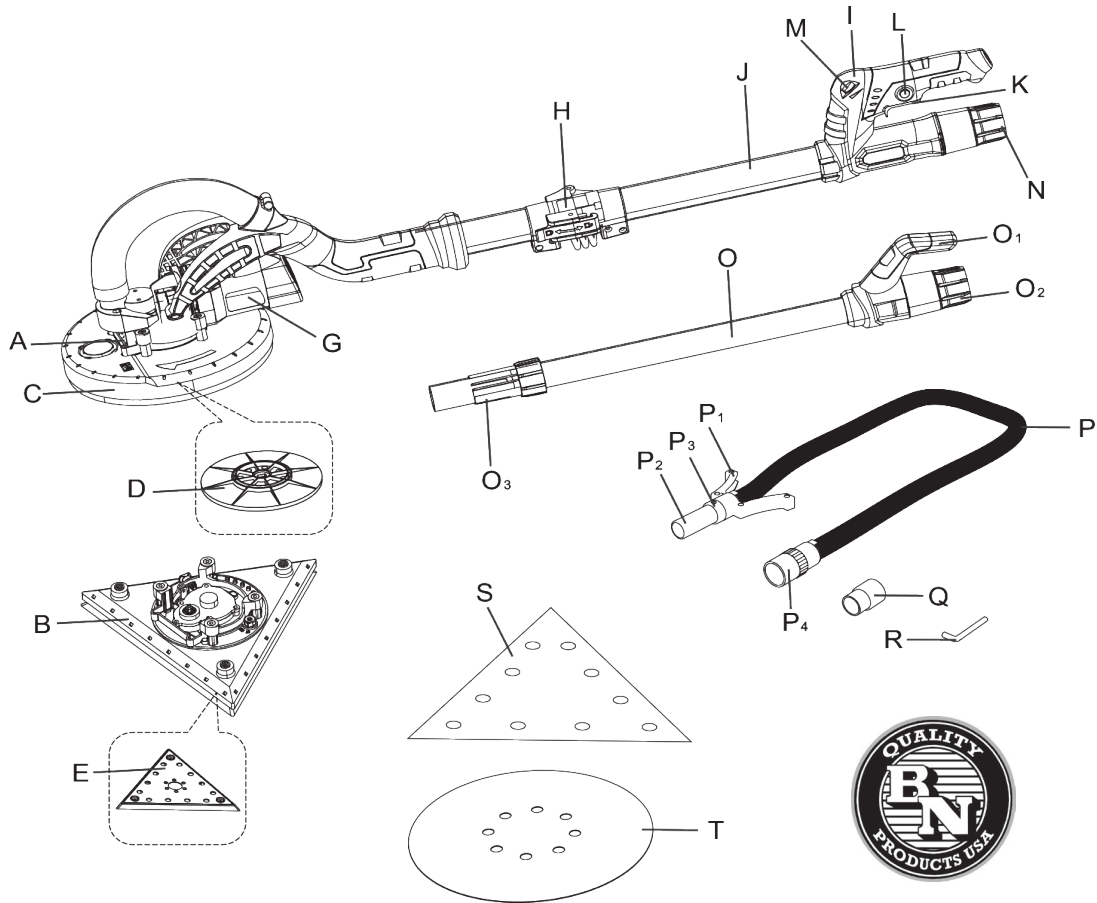

- A - Round sanding head
- B - Triangular sanding head
- C - Brush ring
- D - Round sanding pad (hook & loop system)
- E - Triangular sanding pad (hook & loop system)
- F - Lock lever (pad exchange)
- G - Motor housing
- H - Folding lock
- I - Main handle
- J - Shaft
- K - On/ Off switch
- L - Lock button
- M - Electronic speed control wheel
- N - Dust extraction outlet(with locking sleeve)

- O - Extension shaft
 1. Rear handle
 2. Dust extraction outlet (with adjusting sleeve)
 3. Sleeve
- P - Vacuum hose
 1. Stand
 2. Connector(pre-assembled)(38mm)
 3. Suction power adjustment ring
 4. Vacuum adaptor(pre-assembled)
- Q - Vacuum adaptor(pre-assembled)(35mm)
- R - Hex wrench S5
- S - (SDT) Triangular sanding disc
- T - (SDR1839) Round sanding disc