

Troubleshooting Chart

SYMPTOM	POSSIBLE CAUSE(S)	CORRECTIVE ACTION
Pump does not develop full pressure	<ol style="list-style-type: none"> 1. System relief valve set too low, or leaking 2. Oil temp is too high 3. Pump is worn out 4. Double acting cylinder piston seals are cut or worn out 	<ol style="list-style-type: none"> 1. Check system relief valve for proper setting with pressure gauge in outlet line 2. Let oil cool below 140°F 3. Replace worn parts or pump 4. Replace or repair cylinder
Motor won't start	<ol style="list-style-type: none"> 1. Loose connection 2. Circuit breaker tripped 3. Voltage drop 4. Seized pump 5. Start up load is higher than motor torque capability 	<ol style="list-style-type: none"> 1. Check wiring 2. Reset circuit breaker 3. Use heavier gauge wire 4. Replace pump 5. Use larger motor or reduce operating pressure
Will not pump oil (Motor runs but cylinder does not move, or moves slowly)	<ol style="list-style-type: none"> 1. No oil in reservoir 2. Motor rotating wrong direction 3. Oil level low 4. Suction strainer is clogged 5. Double acting cylinder piston seals are cut or worn out 6. Reservoir breather is dirty or clogged 7. Bi-rotational check valve leaking 	<ol style="list-style-type: none"> 1. Check oil level, refill 2. Change rotation of prime mover or reverse inlet and outlet hoses 3. Add oil as needed 4. Clean suction strainer 5. Replace or repair cylinder 6. Clean reservoir breather and reinstall 7. Remove check valve on pressure side. Clean and reassemble.
Pump motor unit is noisy	<ol style="list-style-type: none"> 1. Low oil level 2. Air in system 3. Suction strainer or inlet filter is clogged 	<ol style="list-style-type: none"> 1. Add oil as needed 2. Bleed air from highest fitting in system by loosening fitting very slightly and operating unit until bubbling of air stops, then tighten 3. Clean suction strainer or inlet filter
Motor operating slow or stalling	<ol style="list-style-type: none"> 1. Excessive slipping of gears due to overheating of oil 2. Excessive wear on the sides of gear housing due to oil contaminants 	<ol style="list-style-type: none"> 1. Check system. Add oil if needed. Oil cooler may be necessary to keep oil at normal operating temperatures 2. Check condition of oil and replace if contaminated
Motor speed is erratic	<ol style="list-style-type: none"> 1. Motor operating below minimum recommended speed of 750 RPM 2. Air in system 	<ol style="list-style-type: none"> 1. Increase minimum operating speed to 750 RPM or more 2. Bleed air from system



Concentric P/N 2690163

revised 07/21/11

READ CAREFULLY BEFORE ATTEMPTING TO ASSEMBLE, INSTALL, OPERATE OR MAINTAIN THE PRODUCT DESCRIBED. PROTECT YOURSELF AND OTHERS BY OBSERVING ALL SAFETY INFORMATION. FAILURE TO COMPLY WITH INSTRUCTIONS COULD RESULT IN PERSONAL INJURY AND/OR PROPERTY DAMAGE! RETAIN INSTRUCTIONS FOR FUTURE REFERENCE.

Description

Our hydraulic pumps are highly efficient and specifically designed for bi-directional rotation. They utilize an external gear fixed displacement design and are of a durable cast iron construction. They incorporate an internally lubricated ball bearing on the drive shaft which will withstand up to 150 lb. side load.

They can be used for direct drive or for belt driven applications. Hydraulic pumps are suitable for use in a wide variety of material handling, agricultural, and construction equipment applications; in addition to machine tools, robotics, and other types of machinery.

Unpacking

Due to cast iron construction, very little damage can occur during transit. Do not remove the plastic shipping plugs from the ports until ready for installation. This will keep dirt or foreign material from entering the system.

Specifications

Cast iron hydraulic pump, bi-rotational, 4-bolt 4F17 mounting, 11 tooth gears, 1.50" shaft extension, 0.50" shaft diameter with 0.125" square x 1" drive key, side porting with SAE straight thread ports, internally lubricated ball bearing for side loads to 150 lbs.

Replacement Parts

Seal & Bearing Kit 2300780

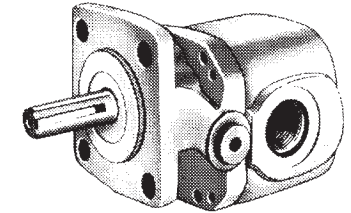

Figure 1

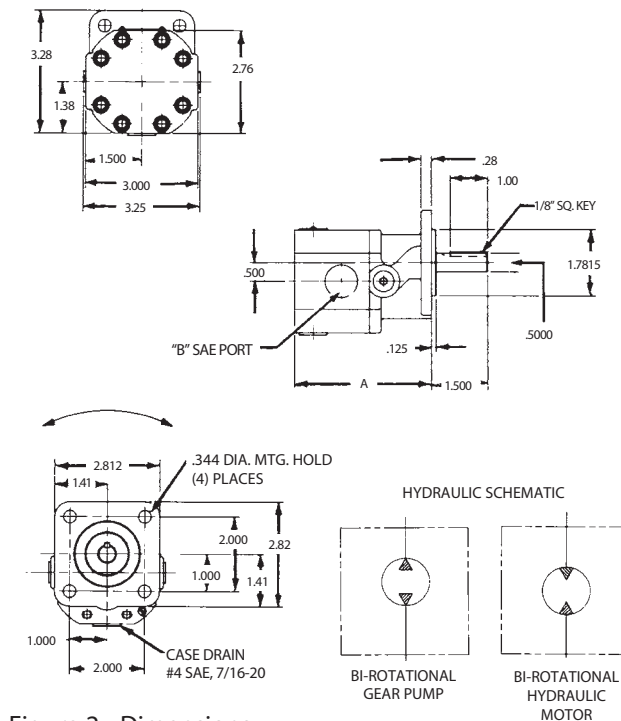

Figure 2 - Dimensions

PUMP/FLUID MOTOR DIMENSIONAL DATA

MODEL	DIMENSIONS	
	A	B
10561	3.16"	9/16-18 SAE #6
10562	3.16"	9/16-18 SAE #6
10563	3.16"	3/4-16 SAE #8
10564	3.16"	3/4-16 SAE #8
10565	3.16"	3/4-16 SAE #8
10566	3.66"	7/8-14 SAE #10
10657	3.66"	7/8-14 SAE #10

⚠ WARNING! ⚠**General Safety Information****DISCONNECT POWER AND RELEASE ALL SYSTEM PRESSURE BEFORE SERVICING THIS EQUIPMENT.**

1. Follow all local electrical and safety codes, as well as the National Electrical Code (NEC) and the Occupational Safety and Health Act (OSHA).
2. Never exceed the maximum operating speed or pressure.
3. When using AC motors, ground the motor properly by wiring with a grounded, metal-clad raceway system, using a separate ground wire connected to bare metal of the motor frame, or other suitable means.
4. Guard all moving parts.
5. Drain all liquids from the system before servicing.
6. Check hoses and connections for security before each use.
7. Periodically check the pump/fluid motor and system components.
8. Provide a means of pressure relief for pumps whose discharge line can be shut off or obstructed.
9. Wear safety glasses at all times when working with pumps/fluid motors.
10. Keep work area clean, uncluttered and properly lighted; replace all unused tools and equipment.
11. Keep visitors at a safe distance from the work area.
12. Make the workshop child-proof with padlocks, master switches, and by removing start keys.
13. Do not operate an engine in an enclosed area.
14. Do not spill gasoline on hot engine surfaces.
15. Store gasoline only in an approved container.
16. Keep dirty and oily cleaning rags in a tightly closed metal container.
17. Check engine oil level before operating the engine.
18. Familiarize yourself with the controls and emergency shutdown procedures.
19. Never operate the equipment when you are fatigued.
20. All system components pressure ratings should be greater than maximum system pressure.
21. Guard all moving parts.
22. Replace all guards when servicing is complete.

Assembly

Models 10561 through 10567 are packaged fully assembled and require no further assembly.

Installation**MOUNTING PUMP ASSEMBLY TO FLEXIBLE COUPLING DRIVE SYSTEMS**

1. Assemble the flexible coupling half to the pump/fluid motor shaft.

⚠ CAUTION ⚠

Do not force coupling half onto drive shaft; it must be a slip fit for adjustment and to avoid internal damage.

2. Tighten the setscrew and insert rubber spider in coupling half.
3. Assemble the other coupling half loosely to the engine/motor shaft.
4. Bolt the pump/fluid motor loosely to the SAE type four bolt mounting pump adapter as furnished by the equipment manufacturer.
5. Align the shafts to make sure they are on center with each other.
6. Tighten the mounting bolts.
7. Mate the coupling halves together, allowing 1/16" gap between halves.
8. Check the alignment again.

IMPORTANT: THE GAP IN THE COUPLING HALVES IS TO PREVENT END LOADING OF THE PUMP/FLUID MOTOR DRIVE.

9. Tighten the setscrew in the mating coupling half.
10. Remove plastic shipping plugs from the inlet and outlet ports.
11. Squirt clean oil into pump for pre-lubrication and start-up.
12. Turn shaft coupling slowly to ensure proper shaft alignment and coupling installation.
13. Connect inlet and outlet lines with an SAE straight thread fitting and tighten.

⚠ CAUTION ⚠

Flush all lines and fittings of contamination.

⚠ WARNING! ⚠

THREADS ARE SAE, NOT NPTF. USING INCORRECT FITTINGS COULD DAMAGE THE HYDRAULIC COMPONENT OR CAUSE PERSONAL INJURY.

NOTE: Do not use teflon tape; the O-ring provides the seal and teflon tape is not required.

14. When using the assembly as a pump keep inlet hose short and of adequate size to avoid pump cavitation.

NOTE: Cavitation is recognized by excessive noise and foaming of hydraulic fluid.

⚠ CAUTION ⚠

Never run assembly without hydraulic oil.

15. At initial start-up, turn the drive shaft several times by hand to prime.
16. Bleed all air from the system to prevent erratic operation.
17. After several cycles, check the reservoir oil level and refill as necessary.

STOCK NO.	DISP. CU.IN./REV.	Flow at * 1800 RPM	Flow at * 3600 RPM	MAX. PRESSURE CONT.	INTER.	Port Size SAE
10561	0.065	0.5	1	3000	4000	9/16-18 SAE #6
10562	0.097	0.75	1.5	3000	4000	9/16-18 SAE #6
10563	0.129	1	2	3000	4000	3/4-16 SAE #8
10564	0.194	1.5	3	3000	4000	3/4-16 SAE #8
10565	0.258	2	4	2300	4000	3/4-16 SAE #8
10566	0.388	3	6	1600	2500	7/8-14 SAE #10
10567	0.517	4	8	1200	2000	7/8-14 SAE #10

* Flow based on 0 pressure and rated in Gallons per minute.

Installation (Continued)

NOTE: Be sure adequate cooling for the hydraulic oil is provided. Excessive temperatures can cause damage to oil and/or system components. Cooling of oil is especially important on systems where continuous operation is required. Cooling requirements must be based on: duty cycle, pressure/flow, ambient temperatures, oil and component maximum temperature specifications, and reservoir capacity. Systems operating at excessively high temperatures can be hazardous and may cause property damage and/or personal injury.

NOTE: When the ambient temperature is below 32°F, allow the pump to operate unloaded for several minutes to warm the oil in the reservoir.

Operation

1. At initial start-up, start and stop several times (jog) to allow the assembly to prime. After lines are full, the pump may be operated at full speed.
2. Bleed all air from hydraulic system to prevent erratic operation.
3. Recheck reservoir oil level after a few complete cycles of the hydraulic system and refill if necessary.

When using as a hydraulic motor

Do not exceed 20 psi at the outlet. If unit is going to be used in series or when outlet pressure exceeds 20 psi, case drain must be plumbed. The case drain port is a 7/16-20 SAE #4 port located on the bottom rear of the unit. Remove plug and run a 1/4" hydraulic line back to a vented reservoir.

⚠ WARNING! ⚠

BE SURE TO DISCONNECT POWER AND RELEASE ALL SYSTEM PRESSURE BEFORE SERVICING THIS EQUIPMENT.

Maintenance

1. Keep the reservoir filled with hydraulic fluid. Recommended Hydraulic Fluids: use a good grade of automatic transmission fluid (ATF).
2. Make frequent inspection of hydraulic fluid and change if contaminated.
3. To fill the reservoir with clean oil: Use a clean funnel fitted with a fine mesh wire screen. Do not use a cloth strainer. Most pump/fluid motor failure, valve malfunctions, and short unit life can be traced directly or indirectly to dirt or other foreign material (water, chips, lint, etc.) getting into, or already in, the hydraulic system.
4. Keep the unit clean of dirt and foreign materials.
5. Keep electrical connections clean.

Common Hydraulic Motor Formulas

$$\text{Torque / 100 psig (in./lbs.)} = \frac{\text{Fluid Motor Displacement (cu. in.)}}{0.0628}$$

$$\text{Speed} = \frac{231 \times \text{Flow Rate (GPM)}}{\text{Fluid Motor Displacement (cu.in.)}}$$

$$\text{Horsepower} = \frac{\text{Torque Output (in./lbs.)} \times \text{RPM}}{63025}$$