

# HEAVY DUTY DOUBLE SPRING SIGN STAND FOR RIGID SIGNS

**MASH  
APPROVED**



Model SS420A

- Holds rigid signs 36" & 48"
- Automotive grade steel, double spring
  - designed to perform in extreme weather conditions without fatiguing or breaking
  - E-coated for maximum rust and corrosion resistance
- Telescoping mast
- Fixed length legs
  - lock in multiple positions to adjust to uneven ground
- Non-skid rubber feet
- Built-in three flag holder
- Replacement parts and assemblies available
- MASH Accepted for 48" - .080 aluminum signs, WZ-355
- Meets MUTCD Standards



Bracket for Rigid Sign  
(patent pending)



## Zinc Plated

Brackets for top and bottom of the sign have different clamp sizes to fit around telescoping mast.



Heavy Duty  
Double Spring

**PLASTICADE®**

Plasticade.com

TF056 Rev. 2

# HEAVY DUTY DOUBLE SPRING SIGN STAND FOR RIGID SIGNS

## Specs

Material Model SS420A	Aluminum
Sign Mounting Height	18" from ground
Top of 48" Sign	86" H maximum
Size Folded	10.5"W x 8.5"D x 82.25"H
Size Open legs collapsed footprint	legs don't collapse
Size Open legs fully extended footprint	38" x 81"
Weight	36 lbs.
Included Bracket	2 Rigid Sign Brackets

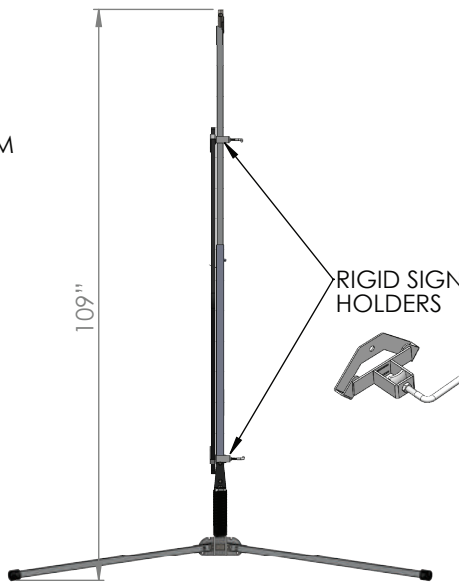
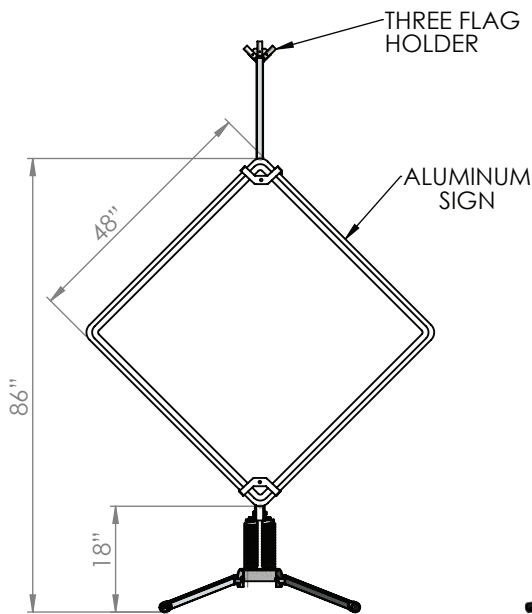
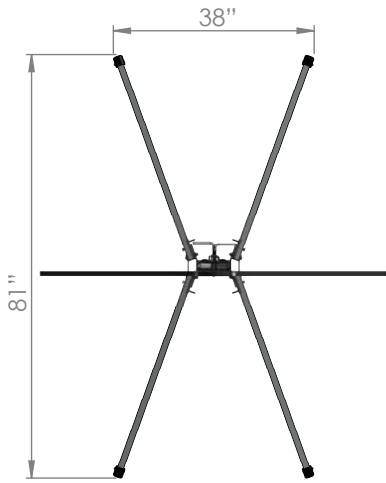

## LEG RELEASE SYSTEM

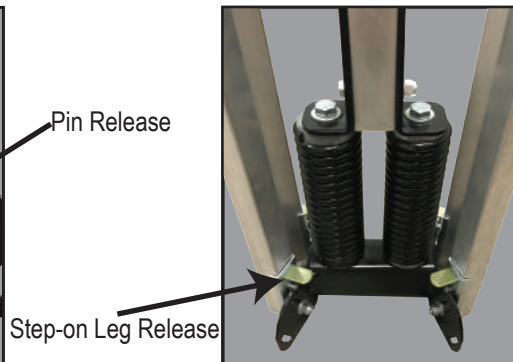
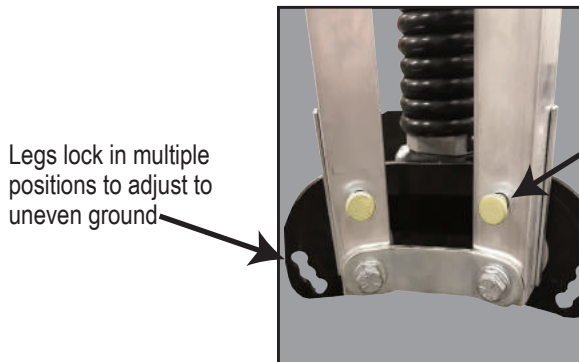

**PLASTICADE®**

100 Howard Avenue  
Des Plaines, IL 60018  
phone (800) 772-0355  
fax (847) 966-8074

[Plasticade.com](http://Plasticade.com)