

Please read and save these instructions. Read carefully before attempting to assemble, install, operate or maintain the product described. Protect yourself and others by observing all safety information. Failure to comply with instructions could result in personal injury and/or property damage! Retain instructions for future reference.

### Operating Instructions and Parts Manual

### Sumps

#### SPECIFICATIONS

<b>POWER SUPPLY REQUIREMENTS</b>	120 V, 60 Hz
<b>MOTOR</b>	Single Phase, Dielectric Oil Filled
<b>HORSEPOWER</b>	1 HP ..... (CDU1000) 3/4 HP ..... (CDU980E) 1/2 HP..... (CICDU800, CDU800, ..... SPF50, CDT50) 1/3 HP ..... (CICDU790, CDU790, .....SPF33, WST33)
<b>LIQUID TEMPERATURE</b>	40° F - 120° F
<b>CIRCUIT REQUIREMENTS</b>	15 A (minimum)
<b>DIMENSIONS</b>	11-1/2 in. high x 9-3/4 in. base
<b>ON LEVEL (FACTORY SET)</b>	Vertical: Approximately 9 in. Tether: Approximately 13 in.
<b>OFF LEVEL (FACTORY SET)</b>	Vertical: Approximately 4 in. Tether: Approximately 7 in.

#### CONSTRUCTION

<b>MOTOR HOUSING</b>	Cast Iron (CICDU800, CICDU790), Stainless Steel, (CDU1000, CDU980E) Coated Steel (CDU800, CDU790, SPF33, SPF50, CDT50) Reinforced Thermoplastic (WST33)	
<b>VOLUTE</b>	<u>CDU1000, CDU980E,</u> <u>CDU800, CDU790, CDT50</u>	<u>SPF33, SPF50, WST33</u>  Glass Reinforced Thermoplastic
<b>IMPELLER</b>	Glass Reinforced Thermoplastic	
<b>SHAFT</b>	Steel	
<b>DISCHARGE</b>	1-1/2 in. NPT	

#### PERFORMANCE

Model	HP	Discharge Head	0 ft	5 ft	10 ft	15 ft	20 ft
CDU1000	1	Gal / hr	6100	5640	5100	4560	3840
CDU980E	3/4	Gal / hr	5490	5076	4600	4100	3500
CICDU800, CDU800, CDT50	1/2	Gal / hr	5100	4500	3840	3060	2040
CICDU790, CDU790	1/3	Gal / hr	4600	3810	3060	2220	1200
SPF50	1/2	Gal/hr	4300	3900	3360	2700	1260
SPF33	1/3	Gal/hr	3750	3300	2718	1920	-
WST33	1/3	Gal/hr	3000	2610	2130	1404	400

\*Images are for illustration purposes only.  
Not all models are shown.

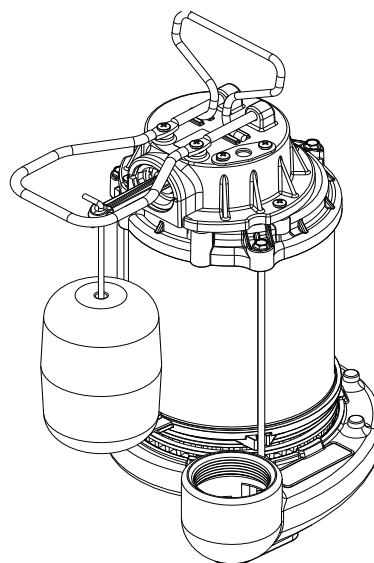

Vertical Float Switch

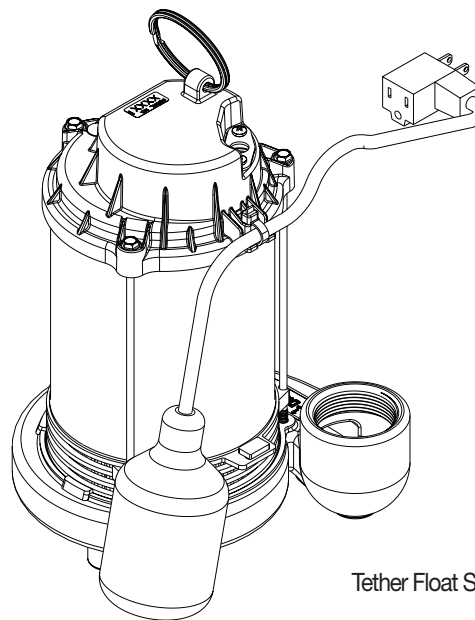

Tether Float Switch

Intended for Indoor Use Only

# INSTALLATION MANUAL

## SUMP PUMP DESCRIPTION

Sump pumps are automatic pumps used to remove ground water from sump pits. The most common application is for basement drainage to prevent flooding in residential buildings. These sumps are designed to pump clear water only. These pumps are not designed to be used with a portable generator. These pumps are intended for indoor use only.

## UNPACKING

Inspect this unit before it is used. Occasionally, products are damaged during shipment. If the pump or components are damaged, return the unit to the place of purchase for replacement, or call Customer Support (800-237-0987).

## NOTICE

**This pump is not designed to handle salt water, brine, laundry discharge, water softener, sewage, grey water, or any other application which may contain caustic chemicals and/or foreign materials. Pump and/or property damage could occur if used in these applications and will void warranty**

## SAFETY SIGNAL WORDS

This manual contains information that is very important to know and understand. This information is provided for SAFETY and to PREVENT EQUIPMENT PROBLEMS. To help recognize this information, observe all safety information labeled danger, warning, caution, and notice.

## IMPORTANT SAFETY INFORMATION CONSIGNES DE SÉCURITÉ IMPORTANTES

### **WARNING**

**WARNING INDICATES A POTENTIALLY HAZARDOUS SITUATION WHICH, IF NOT AVOIDED, COULD RESULT IN DEATH OR SERIOUS INJURY.**

### **AVERTISSEMENT**

**LA MENTION AVERTISSEMENT INDIQUE UNE SITUATION POTENTIELLEMENT DANGEREUSE QUI, SI ELLE N'EST PAS ÉVITÉE, RISQUE D'ENTRAÎNER DES LÉSIONS CORPORELLES GRAVES OU MÊME LA MORT.**

**RISK OF ELECTRIC SHOCK. TO REDUCE THIS RISK, OBSERVE THE FOLLOWING WARNINGS:**

**RISQUE DE CHOC ÉLECTRIQUE. POUR RÉDUIRE CE RISQUE, TENIR COMPTE DES AVERTISSEMENTS SUIVANTS**



**MAKE SURE THERE IS A PROPERLY GROUNDED RECEPTACLE AVAILABLE.** This pump is supplied with a grounding conductor and grounding-type attachment plug. To reduce the risk of electric shock, be certain that it is connected only to a properly grounded, grounding-type receptacle.

**S'ASSURER QU'UNE PRISE DE MISE À LA TERRE EST DISPONIBLE.** Cette pompe est fournie avec un conducteur et une fiche de mise à la terre. Pour réduire le risque de choc électrique, s'assurer qu'elle est branchée seulement à une prise de courant correctement mise à la terre.

**FOR ADDED SAFETY** the receptacle must be protected with a ground fault circuit interrupter (GFCI). All wiring must be performed by a qualified licensed electrician and comply with the National Electric Code and all applicable local codes and ordinances.

**POUR PLUS DE SÉCURITÉ**, la prise de courant doit être protégée par un disjoncteur de fuite à la terre. Tout le câblage doit être effectué par un électricien qualifié et être conforme au Code électrique national et à tous les codes et règlements locaux applicables.

**NEVER REMOVE THE GROUND PRONG** from the plug or bypass the grounding wires.

**NE JAMAIS RETIRER LE CONNECTEUR DE MISE À LA TERRE** de la prise ou contourner les fils de mise à la terre.

**MAKE SURE THE POWER SUPPLY HAS A FUSE OR CIRCUIT BREAKER** rated to handle the current (amps) noted on the pump nameplate or cordtag.

**S'ASSURER QUE L'ALIMENTATION ÉLECTRIQUE EST MUNIE D'UN FUSIBLE OU D'UN DISJONCTEUR** d'une valeur nominale appropriée pour supporter l'intensité du courant (ampérage) indiquée sur la plaque signalétique ou l'étiquette du cordon de la pompe.

**DO NOT REMOVE POWER SUPPLY CORD** and strain relief or connect conduit directly to the pump.

**NE PAS RETIRER LE CORDON D'ALIMENTATION ÉLECTRIQUE** et le réducteur de tension, ni connecter le conduit directement à la pompe.

**ALWAYS DISCONNECT THE PUMP** from power supply before installing, servicing or making any adjustments.

**TOUJOURS METTRE LA POMPE HORS TENSION** avant de procéder à l'installation, à l'entretien ou à des réglages.

**DO NOT WALK** on the floor when water is present until all power is turned off. If the electric panel is in the basement, call an electrician.

**NE PAS MARCHER** sur un sol mouillé avant que l'alimentation générale ne soit coupée. Si le tableau électrique est en sous-sol, appeler un électricien.

PLEASE SEE [WWW.WAYNEPUMPS.COM](http://WWW.WAYNEPUMPS.COM) FOR PRODUCT INFORMATION AND INSTALLATION VIDEOS

**NEVER HANDLE A PUMP** or motor with wet hands or when standing on a wet or damp floor while the pump is plugged into the power supply.

**NE JAMAIS MANIPULER UNE POMPE** ou un moteur de pompe avec les mains mouillées ou debout dans l'eau ou sur une surface humide.

**RISK OF ELECTRIC SHOCK.** This pump has not been investigated for use in swimming pool and marine areas.

**RISQUE DE CHOC ÉLECTRIQUE.** Cette pompe n'a pas fait l'objet de vérification pour une utilisation dans les piscines et les aires marines.

**DO NOT USE TO PUMP FLAMMABLE OR EXPLOSIVE FLUIDS** such as gasoline, fuel oil, kerosene, etc. Do not use in a flammable and/or explosive atmosphere. Pump should only be used to pump clear water. Personal injury and/or property damage will result and void warranty.

**NE PAS UTILISER POUR POMPER DES FLUIDES INFLAMMABLES OU EXPLOSIFS** tels que l'essence, le mazout, le kérosène, etc. Ne pas utiliser dans un environnement inflammable et/ou explosif. La pompe ne doit être utilisée que pour pomper de l'eau claire. Des blessures corporelles et/ou des dégâts matériels pourraient en résulter.

**PUMPS ARE NOT DESIGNED TO TRANSFER WATER INTENDED FOR DRINKING.** Do not use the pump for moving water that will be used for portable/drinking water. Pump should only be used in applications for which it is designed.

**LES POMPES NE SONT PAS CONÇUES POUR L'ACHEMINEMENT D'EAU DESTINÉE À LA CONSOMMATION.** Ne pas utiliser la pompe pour transporter de l'eau qui sera utilisée comme de l'eau potable/destinée à la consommation. La pompe doit être utilisée uniquement dans les applications pour lesquelles elle est conçue.

## WARNING

**DO NOT USE AN EXTENSION CORD OR SURGE PROTECTOR.** Extension cords and/or surge protectors could present a safety hazard if not sized properly, become damaged or the connection falls into the sump. If receptacle is not within reach of the pump's power cord, contact a qualified licensed electrician to install a new receptacle.

## AVERTISSEMENT

**NE PAS UTILISER DE RALLONGE NI DE PROTECTEUR DE SURTENSION.** Les rallonges et/ou les protecteurs de surtension peuvent présenter un danger pour la sécurité s'ils ne sont pas correctement calibrés, s'ils sont endommagés ou si le raccordement tombe dans le puisard. Si la prise n'est pas à portée du cordon d'alimentation de la pompe, contacter un électricien qualifié pour installer une nouvelle prise.

## CAUTION

**CAUTION INDICATES A POTENTIALLY HAZARDOUS SITUATION WHICH, IF NOT AVOIDED, MAY RESULT IN MINOR OR MODERATE INJURY.**

## MISE EN GARDE

**LA MENTION MISE EN GARDE INDIQUE UNE SITUATION POTENTIELLEMENT DANGEREUSE QUI, SI ELLE N'EST PAS ÉVITÉE, POURRAIT ENTRAÎNER DES BLESSURES MINEURES OU MODÉRÉES.**

**TO REDUCE THE RISK OF HAZARDS THAT CAN CAUSE INJURY OR PROPERTY DAMAGE, OBSERVE THE FOLLOWING WARNINGS:**

**POUR RÉDUIRE LE RISQUE DE DANGERS POUVANT CAUSER DES BLESSURES OU DES DÉGÂTS MATÉRIELS, RESPECTER LES MISES EN GARDE SUIVANTES :**



**IT IS THE INSTALLER'S RESPONSIBILITY TO MAKE SURE THE PUMPS AUTOMATIC SWITCH IS ABLE TO OPERATE WITHOUT ANY OBSTRUCTIONS WITHIN THE BASIN.** It is recommended that the installer test and observe the pump's operation for several cycles after installation.

**IL EST DE LA RESPONSABILITÉ DE L'INSTALLATEUR DE S'ASSURER QUE L'INTERRUPTEUR AUTOMATIQUE DE POMPE PEUT FONCTIONNER SANS AUCUN BLOCAGE À L'INTÉRIEUR DU SYSTÈME.** Il est recommandé que l'installateur teste et observe le fonctionnement de la pompe pendant plusieurs cycles après l'installation.

**IT IS REQUIRED TO USE RIGID PIPING AND FITTINGS** to secure the pump in the basin and reduce pump movement. Pump movement can prevent the switch from operating correctly. Do not use flexible hosing.

**IL EST NÉCESSAIRE D'UTILISER DES TUYAUX ET DES RACCORDS RIGIDES** pour fixer la pompe dans le système et réduire les mouvements de la pompe. Les mouvements de la pompe peuvent empêcher l'interrupteur de fonctionner correctement. Ne pas utiliser de tuyaux flexibles.

**IT IS REQUIRED TO USE A CHECK VALVE** with this pump to prevent the back-flow of clear ground water after each pump cycle.

Cette pompe **NÉCESSITE L'UTILISATION D'UNE VANNE DE CONTRÔLE** pour empêcher le reflux d'eau souterraine claire après chaque cycle de pompage.

**DO NOT INSTALL OR OPERATE THE PUMP IF IT HAS BEEN DAMAGED IN ANY WAY.**

**NE PAS INSTALLER OU FAIRE FONCTIONNER LA POMPE SI ELLE A ÉTÉ ENDOMMAGÉE DE QUELQUE MANIÈRE QUE CE SOIT.**

**DO NOT LIFT OR CARRY THE PUMP BY THE POWER CORD.** Use the pump's handle or lift ring.

**NE PAS SOULEVER OU PORTER LA POMPE PAR LE CORDON D'ALIMENTATION.** Utiliser la poignée ou la bague de levage de la pompe.

# INSTALLATION MANUAL

**DO NOT USE THIS PUMP IN MUD, SAND, CEMENT, OIL CHEMICALS, GREY WATER, OR ANY OTHER WATER THAT IS NOT CLEAR GROUND WATER.**

**NE PAS UTILISER CETTE POMPE DANS LA BOUE, LE SABLE, LE CIMENT, LES PRODUITS CHIMIQUES À L'HUILE, DE L'EAU GRISÂTRE OU TOUTE AUTRE EAU QUI N'EST PAS DE L'EAU CLAIRE SOUTERRAINE.**

**DO NOT USE SUMP PUMPS TO HANDLE RAW SEWAGE.**

**NE PAS UTILISER DE POMPES DE PUISARD POUR POMPER LES EFFLUENTS.**

**AN INDEPENDENT HIGH WATER ALARM OR BACK UP PUMP SHOULD BE USED** when risk of property damage from high water levels exists.

**UNE ALARME AUTONOME DE NIVEAU D'EAU ÉLEVÉ OU UNE POMPE DE SAUVEGARDE DOIVENT ÊTRE UTILISÉES** en cas de risque de dégâts matériels causés par des niveaux d'eau élevés.

**REPLACE THE SWITCH EVERY TWO (2) YEARS.** This maintenance will reduce the risk of improper pump operation, switch failure and/or flooding.

**REPLACER LE COMMUTATEUR TOUS LES DEUX (2) ANS.** Cet entretien réduira le risque d'utilisation incorrecte de la pompe, de défaillance de l'interrupteur ou d'inondation.

## ⚠ WARNING

This product can expose you to chemicals, including DEHP, which is known to the State of California to cause cancer, birth defects and reproductive harm. For more information, go to [www.P65Warnings.ca.gov](http://www.P65Warnings.ca.gov).

## ⚠ AVERTISSEMENT

Ce produit peut vous exposer à des produits chimiques, notamment du DOP, reconnu par l'État de Californie comme étant cancérigènes et à l'origine d'anomalies congénitales et de problèmes de l'appareil reproductif. Pour plus de renseignements, visiter le site [www.P65Warnings.ca.gov](http://www.P65Warnings.ca.gov).

## ⚠ WARNING

**VERTICAL FLOAT SWITCH** This float is not adjustable. Any modifications or alterations will void the warranty and/or cause premature failure of the pump, which could lead to property damage.

## ⚠ AVERTISSEMENT

**INTERRUPTEUR À FLOTTEUR VERTICAL.** Ce flotteur n'est pas réglable. Toute modification ou altération peut entraîner une défaillance prématurée de la pompe avec pour conséquences des risques de dégâts matériels. Ces modifications ou altérations annuleront la garantie du matériel.

## ⚠ WARNING

**TETHER FLOAT SWITCH** This float is adjustable. By adjusting the tether switch it can affect the specifications of the application of the pump and can change the life expectancy of the unit.

## ⚠ AVERTISSEMENT

**L'INTERRUPTEUR DU FLOTTEUR À AMARRE** est réglable. L'ajuster peut affecter les spécifications d'utilisation de la pompe et peut en modifier la durée de vie.

## TYPICAL SUMP INSTALLATION DIAGRAMS

### Tether Submersible Sump

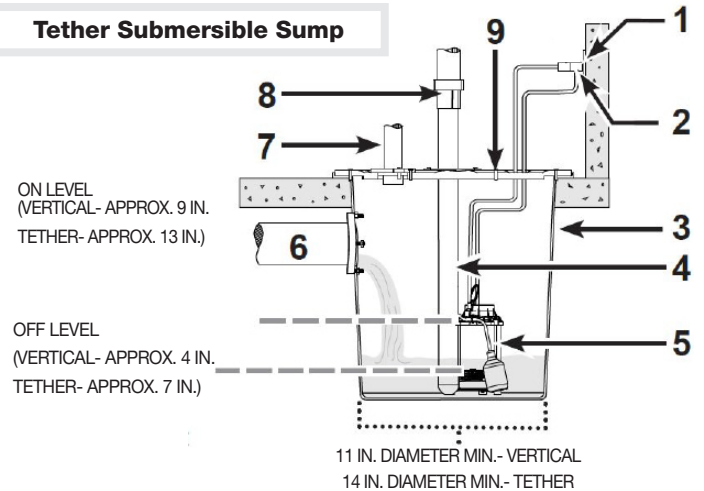

- |                          |                     |
|--------------------------|---------------------|
| 1. GFCI GROUNDED OUT-LET | 6. INLET            |
| 2. PIGGYBACK PLUG        | 7. VENT PIPE        |
| 3. BASIN                 | 8. CHECK VALVE      |
| 4. DISCHARGE PIPE        | 9. GASKET/BASIN LID |
| 5. PUMP                  |                     |

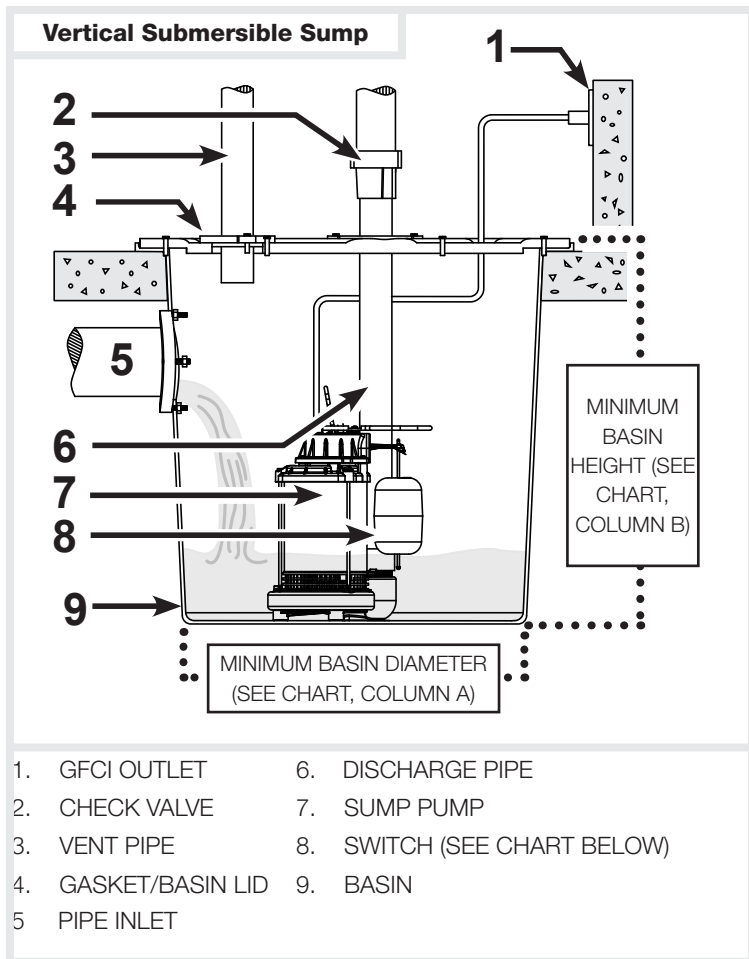

## TYPICAL SUMP INSTALLATION

1. This installation must be in accordance with the National Electric Code and all applicable local codes and ordinances.
2. Use a basin (purchased separately) or pit that is large enough to accommodate the pump. The minimum requirements for the sump pumps are:

Basin/Pit Size Specifications		A Minimum Basin Diameter	B Minimum Basin Height
Switch Type	Tether Float Switch	14 in.	22 in.
	Vertical Float Switch	11 in.	22 in.

3. Clean the basin/pit of all debris.
4. Assemble switch or float if needed.

5. If using a basin, place the pump directly on the bottom of the basin. To prevent damage set the pump on a solid, level surface. Do not place pump directly on clay, earth, gravel or sand. A brick or block must be installed under the pump to provide a solid base.
6. Position pump so the switch is away from the inlet so switch is clear from incoming water. Verify the switch has at least 1 in. clearance to the side wall of the basin and is free to move throughout its movement. If optional control device or float is used, follow mounting instruction supplied with device or float.
7. Install discharge plumbing according to local, regional and state codes. Rigid PVC pipe is required. Do not use flex hosing in a permanent application.
8. Install a check valve (required) to prevent back-flow. The check valve may be positioned just above the basin to allow easy removal of the pump for cleaning and service.
9. Install a gate valve or ball valve if required by local, regional or state code.
10. Secure power supply cord to discharge pipe using cable or zip ties to prevent possible switch entanglement.
11. Connect pump power supply cord to a ground fault circuit interrupter (GFCI) receptacle.
12. Fill the basin/pit with water. The pump will start when the water level has reached the switch-on level.
13. The pump will stop when the water level has reached the switch-off level.
14. Verify the switch is operating without any obstruction from the pump, piping and basin.
15. Fill the basin/pit with water again. While the pump is draining the basin/pit, verify the discharge pipe is carrying the water to a point at least 3 ft. away from the foundation. If the discharge line is exposed to freezing temperatures, the pipe must be positioned in a downward slope away from the foundation so any remaining water will drain away and not freeze.
16. Secure the basin cover and gasket to the basin to prevent debris from falling into the basin, prevent personal injury, and to contain gases and/or odors.

# INSTALLATION MANUAL

## TROUBLESHOOTING WARNINGS

### **WARNING**

**ALWAYS DISCONNECT THE PUMP FROM POWER SUPPLY** before installing, servicing or making any adjustments.

### **AVERTISSEMENT**

**TOUJOURS METTRE LA POMPE HORS TENSION** avant de procéder à l'installation, à l'entretien ou à des réglages.

### **WARNING**

**LET PUMP COOL FOR A MINIMUM OF 2 HOURS BEFORE ATTEMPTING TO SERVICE.** Submersible pumps contain oil that become pressurized and hot under normal operating conditions.

### **AVERTISSEMENT**

**LAISSER REFROIDIR LA POMPE PENDANT AU MOINS 2 HEURES AVANT D'ESSAYER DE LA RÉPARER.** Les pompes submersibles contiennent de l'huile qui devient pressurisée et chaude dans des conditions normales de fonctionnement.

1. Submersible pump models have permanently lubricated bearings and require no additional lubrication.
2. Submersible pumps contain dielectric oil for cooling. Dielectric oil can be harmful to the environment. Follow state environmental laws when disposing of oil.
3. The pump motor is equipped with automatic resetting thermal protector and may restart unexpectedly. Protector tripping is an indication of motor overloading as a result of operating the pump at low heads, excessively high or low voltage, inadequate wiring, incorrect motor conditions, or at the end of its life.

## TROUBLESHOOTING CHART

<b>Symptoms</b>	<b>Possible Cause(s)</b>	<b>Suggested Remedies</b>
Pump will not start or run	<ol style="list-style-type: none"><li>1. Water level too low</li><li>2. Blown fuse or tripped circuit breaker</li><li>3. Low supply voltage</li><li>4. Motor</li><li>5. Switch</li><li>6. Inlet screen clogged</li><li>7. Switch obstruction</li></ol>	<ol style="list-style-type: none"><li>1. Water must be at the appropriate level to activate switch</li><li>2. If blown, determine cause and then either replace with proper sized fuse or reset breaker</li><li>3. Contact an electrician</li><li>4. Replace pump</li><li>5. Replace switch</li><li>6. Remove debris</li><li>7. Remove obstruction to ensure free motion of switch</li></ol>
Pump starts and stops too often	<ol style="list-style-type: none"><li>1. Back-flow of water from discharge pipe</li><li>2. Switch</li><li>3. Check valve not functioning properly or leaking</li></ol>	<ol style="list-style-type: none"><li>1. Install check valve</li><li>2. Replace switch</li><li>3. Remove and examine check valve for proper installation and free operation. Replace check valve if necessary.</li></ol>
Pump shuts off and turns on independently of switch (trips thermal overload protection)	<ol style="list-style-type: none"><li>1. Excessive water temperature</li><li>2. Switch</li><li>3. Switch obstruction</li><li>4. Obstruction in discharge pipe</li><li>5. Low supply voltage</li></ol>	<ol style="list-style-type: none"><li>1. Pump should not be used for water above 120° F</li><li>2. Replace switch</li><li>3. Remove obstruction to ensure free motion of switch</li><li>4. Remove obstruction in discharge piping</li><li>5. Contact an electrician.</li></ol>

## TROUBLESHOOTING CHART (CONTINUED)

<i>Symptoms</i>	<i>Possible Cause(s)</i>	<i>Suggested Remedies</i>
Pump operates noisily or vibrates excessively	<ol style="list-style-type: none"> <li>1. Worn bearings</li> <li>2. Impeller broken</li> <li>3. Piping attachments to building structure too rigid or too loose</li> </ol>	<ol style="list-style-type: none"> <li>1. Replace pump</li> <li>2. Replace pump</li> <li>3. Install rubber coupling (available at local hardware stores) to isolate pump vibration from discharge plumbing</li> </ol>
Pump will not shut off	<ol style="list-style-type: none"> <li>1. Switch</li> <li>2. Switch obstructions</li> <li>3. Restricted discharge (obstruction in piping)</li> <li>4. Excessive inflow or pump not properly sized for application</li> </ol>	<ol style="list-style-type: none"> <li>1. Replace switch</li> <li>2. Remove obstruction to ensure free motion of switch</li> <li>3. Remove obstruction from discharge piping</li> <li>4. Recheck all sizing calculations to determine proper pump size</li> </ol>
Pump operates but delivers little or no water	<ol style="list-style-type: none"> <li>1. Low supply voltage</li> <li>2. Inlet screen clogged</li> <li>3. Broken impeller</li> <li>4. Pump not properly sized for application</li> <li>5. Check valve stuck closed or installed backwards</li> <li>6. Shut off valve closed</li> </ol>	<ol style="list-style-type: none"> <li>1. Contact an electrician</li> <li>2. Remove debris</li> <li>3. Replace pump</li> <li>4. Recheck all sizing calculations to determine proper pump size</li> <li>5. Remove and examine check valve for proper installation and free operation</li> <li>6. Open valve</li> </ol>

## ROUTINE SUMP MAINTENANCE

The pump should be inspected 3-4 times per year for pump movement or buildup of debris on the switch or float. Reposition pump if it has moved. Remove any debris that could interfere with the operation of the switch. Lack of proper routine maintenance will void warranty.

- Make sure the pump is plugged in to a working ground fault circuit interrupter (GFCI) outlet and the cord is in good shape. In damp areas, GFCI breakers may trip, effectively shutting off the sump pump. Check in on your sump pump and reset the GFCI if necessary.
- Ensure the pump itself is standing upright. Vibrations during operation can cause it to fall or tilt onto one side. This can jam the float arm so it can't activate the pump.
- Pour a bucket of water into the pit to make sure the pump starts automatically and the water drains quickly once the pump is on. If the pump doesn't start, have it serviced or replaced.
- Check the inlet screen and clear away any small stones or debris.
- Replace the switch every two (2) years. This maintenance will reduce the risk of improper pump operation, switch failure and/or flooding.



**FOR REPLACEMENT  
PARTS OR CUSTOMER SUPPORT,  
CALL 1-800-237-0987**

**ADDRESS PARTS CORRESPONDENCE TO:  
WAYNE Water Systems  
101 Production Drive  
Harrison, OH 45030 U.S.A.**

**Please provide following information:**

- Model number
- Serial number on cord tag (not to be removed)
- Part description and number as shown in parts list

**Thank you** for making Wayne Water Systems a key part of your home maintenance program. If properly installed, maintained and operated in accordance with Wayne Water Systems' written instructions, your pump should provide you with approximately ( \* ) years of service.

Product Warranty	( * ) Expected Life
1	3
2	3
3	6
5	6

## LIMITED WARRANTY

For one year for SPF33 and SPF50 models, two years for CDT50, WST33, three years for CDU790, CICDU790, CDU800, and CICDU800 models, and five years for CDU980E and CDU1000 from the date of purchase, from an authorized dealer, Wayne Water Systems will repair or replace, at its option for the original purchaser, any part or parts of its Sump Pumps or Water Pumps ("Product") found upon examination by Wayne Water Systems to be defective in materials or workmanship. Please call Wayne Water Systems (800-237-0987) for warranty instructions. Be prepared to provide the model number and the serial number when exercising this warranty. All transportation charges on Products or parts submitted for repair or replacement must be paid by purchaser. This Limited Warranty is not transferrable. This Limited Warranty does not cover Products which have been damaged as a result of accident, abuse, misuse, neglect, improper installation, improper maintenance, or failure to operate in accordance with WAYNE's written instructions.

This Limited Warranty does not cover Products which have been damaged as a result of accident, abuse, misuse, neglect, improper installation, improper maintenance, or failure to operate in accordance with Wayne Water Systems' written instructions.

**THIS WARRANTY IS IN LIEU OF ANY AND ALL OTHER WARRANTIES, OBLIGATIONS OR AGREEMENTS, EXPRESSED OR IMPLIED, INCLUDING ANY IMPLIED WARRANTY OF MERCHANTABILITY OR FITNESS FOR ANY PARTICULAR PURPOSE, AND ANY RIGHTS OR REMEDIES AGAINST ANY PERSON OR ENTITY UNDER THE UNIFORM COMMERCIAL CODE OR OTHERWISE WITH RESPECT TO THE SALE OF THE PRODUCT. THE REMEDIES AND OBLIGATIONS STATED IN THIS WARRANTY ARE THE SOLE AND EXCLUSIVE REMEDIES OF AND OBLIGATIONS TO THE OWNER FOR ANY AND ALL MATTERS ARISING WITH RESPECT TO OR IN ANY WAY CONNECTED WITH THE PRODUCT, REGARDLESS OF THE SOURCE OR PROVIDER OF SUCH GOODS. IN NO EVENT, WHETHER AS A RESULT OF BREACH OF CONTRACT, WARRANTY TORT (INCLUDING NEGLIGENCE) OR OTHERWISE, SHALL WAYNE WATER SYSTEMS OR ANY AFFILIATE BE LIABLE FOR ANY SPECIAL, INCIDENTAL OR CONSEQUENTIAL DAMAGES.**

You **MUST** retain your purchase receipt along with this form. In the event you need to exercise a warranty claim, you **MUST** send a **copy** of the purchase receipt along with the material or correspondence. Please call Wayne Water Systems (800-237-0987) for return authorization and instructions.

**DO NOT MAIL THIS FORM TO Wayne Water Systems.** Use this form only to maintain your records.

MODEL NO. \_\_\_\_\_ SERIAL NO. \_\_\_\_\_ INSTALLATION DATE \_\_\_\_\_





