



## **LOW NOISE AIR DIE GRINDER OWNER'S MANUAL**



 **WARNING:** Read carefully and understand all **INSTRUCTIONS** before operating. Failure to follow the safety rules and other basic safety precautions may result in serious personal injury.

**Item #100800**

Thank you very much for choosing a NORTHERN TOOL + EQUIPMENT CO., INC. Product! For future reference, please complete the owner's record below:

Model: \_\_\_\_\_ Purchase Date: \_\_\_\_\_

Save the receipt, warranty and these instructions. It is important that you read the entire manual to become familiar with this product before you begin using it.

This machine is designed for certain applications only. Northern Tool + Equipment cannot be responsible for issues arising from modification. We strongly recommend this machine is not modified and/or used for any application other than that for which it was designed. If you have any questions relative to a particular application, DO NOT use the machine until you have first contacted Northern Tool + Equipment to determine if it can or should be performed on the product.

For technical questions please call **1-800-222-5381**.

### **INTENDED USE**

This Low Noise Extended Air Grinder is designed to sand and smooth cylindrical objects and remove spurs for smoothness and optimum surface contact.

### **TECHNICAL SPECIFICATIONS**

<b>Item</b>	<b>Description</b>
Noise Level	87dB
Cutting Speed	18,000 RPM Free Speed
Air Consumption	3.4 CFM
Inlet Size	1/4in.
Hose Size	3/8in.

### **GENERAL SAFETY RULES**



**WARNING:** Read and understand all instructions. Failure to follow all instructions listed below may result in electric shock, fire and/or serious injury.



**WARNING:** The warnings, cautions, and instructions discussed in this instruction manual cannot cover all possible conditions or situations that could occur. It must be understood by the operator that common sense and caution are factors, which cannot be built into this product, but must be supplied by the operator.

### **SAVE THESE INSTRUCTIONS**

## **WORK AREA**

- **Keep work area clean**, free of clutter and well lit. Cluttered and dark work areas can cause accidents.
- **Do not use your Air Grinder where there is a risk of causing a fire or an explosion;** e.g. in the presence of flammable liquids, gasses, or dust. An Air Grinder can create sparks, which may ignite the dust or fumes.
- **Keep children and bystanders** away while operating the Air Grinder. Distractions can cause you to lose control, so visitors should remain at a safe distance from the work area.
- **Be aware of all power lines, electrical circuits**, water pipes and other mechanical hazards in your work area, particularly those hazards below the work surface hidden from the operator's view that may be unintentionally contacted and may cause personal harm or property damage.
- **Be alert of your surroundings.** Using the Air Grinder in confined work areas may put you dangerously close to cutting tools and rotating parts.

## **PERSONAL SAFETY**

- **Stay alert**, watch what you are doing and use common sense when operating the Air Grinder. Do not use the Air Grinder while you are tired or under the influence of drugs, alcohol or medication. A moment of inattention while operating the Air Grinder may result in serious personal injury.
- **Dress properly.** Do not wear loose clothing, dangling objects, or jewelry. Keep your hair, clothing and gloves away from moving parts. Loose clothes, jewelry or long hair can be caught in moving parts. Air vents often cover moving parts and should be avoided.
- **Use safety apparel and equipment.** Use safety goggles or safety glasses with side shields which comply with current national standards, or when needed, a face shield. Use as dust mask in dusty work conditions. This applies to all persons in the work area. Also use non-skid safety shoes, hardhat, gloves, dust collection systems, and hearing protection when appropriate.
- **Do not overreach.** Keep proper footing and balance at all times.
- **Remove adjusting keys or wrenches** before connecting to the power supply or turning on the tool. A wrench or key that is left attached to a rotating part of the tool may result in personal injury.

## **PNEUMATIC TOOL USE AND CARE**

- **Do not force the tool.** Pneumatic tools do a better and safer job when used in the manner for which they are designed. Plan your work, and use the correct tool for the job.
- **Never use a tool** with a malfunctioning switch. Any power tool that cannot be controlled with the switch is dangerous and must be repaired by an authorized service representative before using.
- **Disconnect air supply** from tool and place the switch in the locked or off position before making any adjustments, changing accessories, or storing power tools. Such preventive safety measures reduce the risk of starting the power tool accidentally.
- **Secure work** with clamps or a vise instead of your hand to hold work when practical. This safety precaution allows for proper tool operation using both hands.

- **Store idle tools.** When tools are not in use, store them in a dry, secure place out of the reach of children. Inspect tools for good working condition prior to storage and before re-use.
- **Use only accessories that are recommended** by the manufacturer for your model. Accessories that may be suitable for one tool may create a risk of injury when used on another tool.
- **Keep guards in place** and in working order.
- **Never leave tool** running unattended.
- **USE COMPRESSED AIR ONLY.** Use clean, dry and regulated compressed air to power this tool. Never use oxygen, carbon dioxide or any other bottled gas as a power source for this tool.

## TOOL SET UP

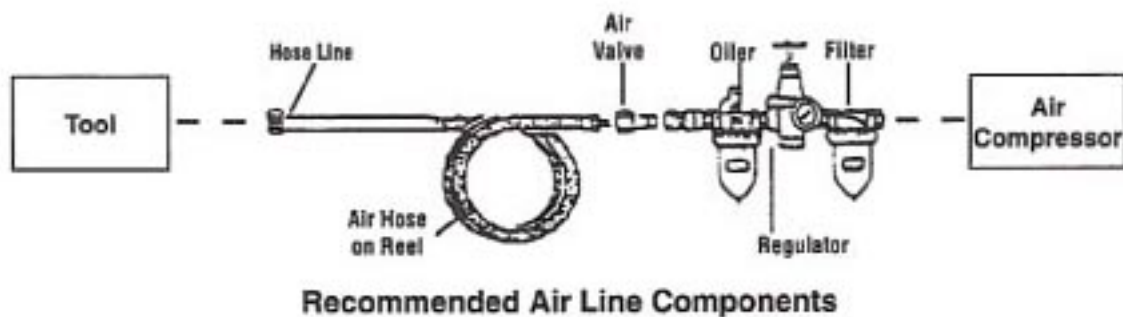

Fig. 1 (Above) shows an optimal set-up that includes an inline filter, regulator and oiler. All of these components are sold separately through Northern Tool + Equipment.

**NOTE:** If you are not using an automatic oiler system, before operation, add a few drops of Pneumatic Tool Oil to the airline connection. Add a few drops more after an hour of continual use.

1. Prepare the 1/4in. air nipple to connect to the air inlet on the Air Grinder. First, wrap the 1/4in. air nipple with pipe thread seal tape (not included) before threading it into the inlet. Connect the 3/8in. I.D. air hose (not included) to a quick-disconnect coupler (not included) and then to the air nipple.
2. Turn on the air pressure on your compressor to 90 PSI. Do not exceed the recommended air pressure of 90 PSI.
3. Check the air connection for leaks.

## AIR SUPPLY



**WARNING:** Ensure the air supply is clean and does not exceed 90 PSI while operating the tool. Too much air pressure and unclean air will shorten the product life due to excessive wear, and may cause damage and/or personal injury.

1. Make sure that the air valve (or trigger) is in the "off" position before connecting to the air supply.

2. An air pressure of 90 PSI is required.
3. Drain the air tank daily. Water in the airline can damage the tool.
4. Clean the air inlet filter weekly.
5. Line pressure should be increased to compensate for longer air hoses (over 26 feet or 8 meters). The hose diameter should be 3/8in. I.D.
6. Keep the hose away from heat, oil and sharp edges. Check the hose for wear and make certain that all connections are secure.

## **MAINTENANCE**



**WARNING:** Make sure the Air Grinder is disconnected from its power source before attempting any maintenance, cleaning, or inspection.

- Maintain your Air Grinder. It is recommended that the general condition of any tool be examined before it is used. Keep your Air Grinder in good repair by adopting a program of conscientious repair and maintenance in accordance with the recommended procedures found in this manual. If any abnormal vibrations or noise occurs, turn the Air Grinder off immediately and have the problem corrected before further use. Have necessary repairs made by qualified service personnel.
- Keep all cutting tools sharp and clean. Properly maintained cutting tools with sharp cutting edges are less likely to bind and are easier to control. Keep handles dry, clean, and free from oil and grease.
- Cleaning. Use only soap and a damp cloth to clean your Air Grinder. Many household cleaners are harmful to plastics and other insulation. Never let liquid get inside the Air Grinder.

## DIAGRAM & PARTS LIST

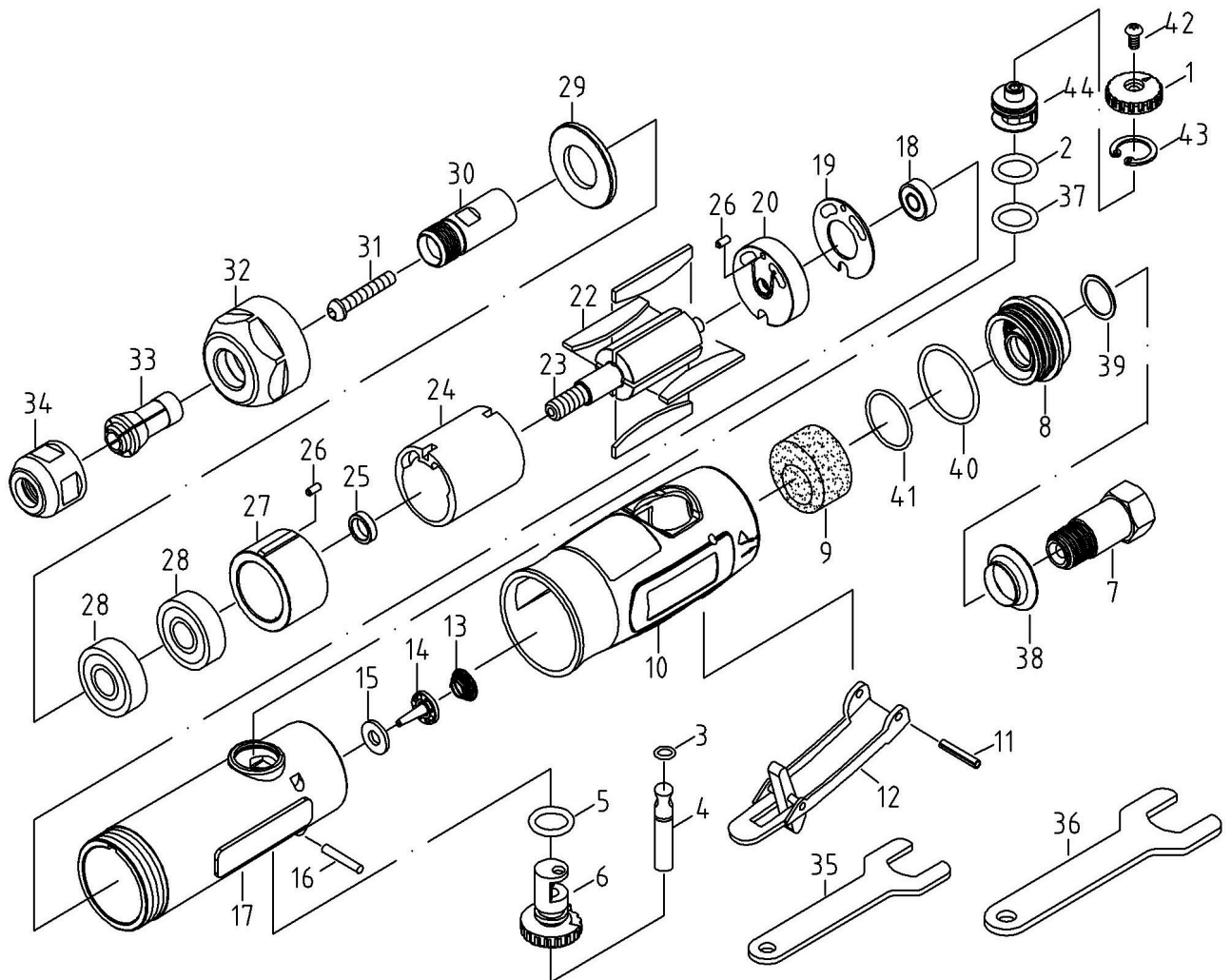

No	Part No	Description	Qty	No	Parts No	Description
1	ST25101A	Regulator	1	24	ST21315	Cylinder
2	ST25102	O-Ring (AS015)	1	25	ST25125	Bearing Spacer
3	OB-04	O-Ring (3.5 x 1.4)	1	26	70018	Pin (2.5 x 6L)
4	OB-05	Valve Stem	1	27	ST25127	Front Plate
5	OB-02	O-Ring (P10)	1	28	ST25128	Bearing (6000ZZ)
6	ST25106	Regulator	1	29	ST25129	Washer
7	ST25107A	Air Inlet	1	30	265A33	Spindle
8	ST25108A	Exhaust Sleeve	1	31	ST25139A	Screw (M5 x 15L)
9	ST25109	Silencer	1	32	ST25232	Clamp Nut
10	ST250R10	Protecting Rubber	1	33	21036	Collet

11	12012.1	Spring Pin (3 x 24l)	1	34	21037	Collet Nut
12	ST25112	Lever	1	35	BT21038-14	Stop Spanner (14mm)
13	ST288314	Spring	1	36	BT21039-19	Stop Spanner (19mm)
14	ST288315	Valve	1	37	ST25150	O-Ring (S16)
15	ST288316	Washer	1	38	ST20036	Muffler Body
16	ST25116A	Pin (2.8 x 25.8L)	1	39	LDB250R43	Washer
17	ST25117	Housing	1	40	LDB250R45	O-Ring (AS125)
18	22536A	Bearing (626ZZ)	1	41	LDB250R46	O-Ring (S30)
19	ST25119	Washer	1	42	81447	Screw (M4 x 8)
20	ST25120	Rear Plate	1	43	ST25148	Snap Ring (RTW-18)
22	ST25122	Rotor Blade	4	44	ST25101A-1	Regulator
23	ST25123	Rotor	1			

For replacement parts and technical questions, please call **1-800-222-5381**.

## WARRANTY

### One-Year Limited Warranty

# WARNING

Some dust created by power sanding, sawing, grinding, drilling, and other construction activities contains chemicals known to the State of California to cause cancer, birth defects or other reproductive harm. Some examples of these chemicals are:

- Lead from lead-based paints
- Crystalline silica from bricks and cement and other masonry products
- Arsenic and chromium from chemically treated lumber

Your risk from these exposures varies, depending on how often you do this type of work. To reduce your exposure to these chemicals: work in a well-ventilated area, and work with approved safety equipment, such as those dust masks that are specially designed to filter out microscopic particles.



Distributed by  
Northern Tool + Equipment Co.,  
Burnsville, MN 53306  
Made in Taiwan