

POWERHORSE™

Owner's Manual

M6075636A.1

ITEM NUMBER: 6075636

SERIAL NUMBER: _____

Instructions for Installation/Set-up, Operation, Servicing, & Storage Portable, Outdoor Use-Only, Dual Fuel Generator

6075636 – 18,000 Watt Continuous (27,000 Watt Surge) Capacity

Can be used to power individual appliances plugged directly into the generator's outlets, or as a back-up connection to a building's power supply (via a professionally installed UL-listed transfer switch).

⚠ WARNING – READ THIS MANUAL

READ and UNDERSTAND this manual completely before using the generator! Failure to properly set up, operate, and maintain this generator could result in **serious injury or death** from **carbon monoxide poisoning, electric shock, fire/explosion, or burns**. In particular, be aware of the following hazards:

CO Poisoning

Generators give off carbon monoxide, a poisonous gas that can kill you. You CANNOT smell it, see it, or taste it.

- ONLY run generator OUTDOORS and AWAY from building air intakes. NEVER run generator inside any enclosed or semi-enclosed spaces, including homes, basements, garages, sheds, boxes, RVs, boats or pick-up truck beds. These spaces can trap poisonous gases, EVEN if you run a fan or open windows.
- Install carbon monoxide alarms inside nearby structures/buildings (battery-operated, or plug-in with battery back-up).

Electric shock / Electrocutation

- High voltage electricity from generator can kill. DO NOT operate in wet locations. Be sure generator is properly grounded. Use only UL-listed, outdoor-rated grounded extension cords of proper size.
- NEVER plug the generator directly into a wall outlet. ANY connection to a building's electrical system MUST ISOLATE THE GENERATOR FROM UTILITY POWER via a UL-listed transfer switch installed by a licensed electrician. Otherwise, back feed from the generator into the power grid could kill utility workers.

Fire / Explosion

- DO NOT overload generator (per rated capacity), and OPERATE ONLY in an area with adequate cooling ventilation so engine does not overheat. Exhaust can be extremely hot. Keep muffler at least 7 feet from all combustible objects.
- All fuels are flammable. Never fuel a running or hot engine. Never pump fuel directly into generator at gas station – use approved container to transfer fuel. Ensure there are no fuel leaks, and keep sources of sparks and flames away.
- ALWAYS keep a fire extinguisher rated "ABC" nearby.

STOP!

CHOOSE THE RIGHT GENERATOR FOR YOUR NEEDS. See the Power Load Planning & Management section of this manual to determine your power load requirements and then compare to the generator's rated capacity.

INSPECT COMPONENTS: Closely inspect to make sure no components are missing or damaged. See the Unpacking & Delivery Inspection section for instructions on whom to contact to report missing or damaged parts.

ARRANGE FOR PROFESSIONAL INSTALLATION of a transfer switch if you will be connecting the generator to your building's electrical system. See the Installation/Initial Set-Up section for more information about this requirement.

ADD ENGINE OIL: Engine is shipped without oil. See engine section of this manual for instructions on capacity and viscosity recommendations.

Any Questions, Comments, Problems, or Parts Orders
Call Powerhorse Product Support 1-866-443-2576

Hazard Signal Word Definitions



This is the safety alert symbol. It is used to alert you to potential personal injury hazards. Obey all safety messages that follow this symbol to avoid possible injury or death.

⚠ DANGER

DANGER indicates a hazardous situation, which if not avoided, will result in death or serious injury.

⚠ WARNING

WARNING indicates a hazardous situation, which if not avoided, could result in death or serious injury.

⚠ CAUTION

CAUTION used with the safety alert symbol, indicates a hazardous situation, which if not avoided, could result in minor or moderate injury.

CAUTION

CAUTION without the safety alert symbol, is used to address practices not related to personal injury.

NOTICE

NOTICE is used to address practices not related to personal injury.

Table of Contents

- Hazard Signal Word Definitions 2**
- About Your Generator 4**
- Specifications 6**
- Safety Label Locations 7**
- Machine Component Identification 9**
- Installation / Initial Set-Up:**
 - 1. Unpacking & Delivery Inspection..... 12
 - 2. Planning the Power Load 13
 - 3. Propane Hookup..... 15
 - 4. Set-up as a BUILDING BACK-UP or PORTABLE Power Source 16
 - 5. Selecting a Suitable Site 18
 - 6. Grounding the Generator 20
 - 7. Battery Installation..... 21
 - 8. Wheel Kit Assembly 22
 - 9. Propane Tank Connection 23

- Operation:**
 - 1. General Safety Rules for Operation 25
 - 2. Preparing for Operation..... 28
 - 3. Starting the Engine..... 31
 - 4. Checking Generator Output 32
 - 5. Connecting Loads 33
 - 6. Stopping the Engine..... 33
 - 7. Storage & Exercise 34

- Maintenance & Repair 35**
- Troubleshooting 37**
- Summary of Important Safety Information for Operation 38**
- Engine Operation 42**
- Exploded Views 48**
- Warranty 54**

About Your Generator

Thank you for purchasing your Powerhorse portable generator!

About Your Generator

This engine-driven, portable generator is designed to provide electrical power up to 27,000 watts surge (18,000 watts continuous) on gasoline and 24,300 watts surge (16,200 watts continuous) on propane. It can supply power:

1. As a portable power source. You can plug appliances directly into the generator's electrical outlets.
2. As a back-up, standby power source for a building. A licensed electrician can connect the generator to your building's electrical system via the installation of an **UL-listed transfer switch**. (See the "Installation & Initial Set-up" section of this manual to learn more about specific requirements and precautions relating to wiring the generator to your building's electrical system.)

You must select a generator adequately sized for your power needs.

You need to determine the power needs of all the appliances/tools you wish to power at the same time and choose a generator rated to provide at least that power level. See the "Planning the Power Load" section of this manual to determine your specific power load requirements and then compare them to this generator's rated capacity. You must not overload the generator. Overloading will cause damage to the generator and attached electrical devices, and may also result in fire.

You can power this generator with gasoline or propane.

However, there are special initial hook-up requirements for propane. See the "Specifications" section of this manual with regard to specific gas flow and pressure requirements. In addition, note the following: You will need a minimum 20 lb. propane tank to run this generator – the vaporization rate is insufficient with smaller tank sizes. A certified propane technician must set up the valve and hose connection between the propane tank and generator in accordance with all federal and local requirements.

See the "Installation/Initial Set-Up: Step 3" section of this manual for more detailed information.

Be sure to read about site selection and grounding requirements for running this generator. More detailed information can be found in the "Installation & Initial Set-up, Steps 5 & 6" of this manual.

Contact Powerhorse Product Support at 1-866-443-2576 with questions about optional accessories or to order parts.

Read this Manual

WARNING

Improper use or maintenance of this generator can result in ***serious injury or death*** from ***carbon monoxide poisoning, electric shock/electrocution, fire/explosion, or burns***.

Read this manual completely before using the generator and follow all instructions and safety rules.

You must follow all instructions and safety precautions presented throughout this manual. A summary of important safety information can be found at the end of the manual. Keep this manual for reference and review.

About Your Generator (continued)

Proper preparation, operation, and maintenance will result in operator safety, as well as best performance and long life of the generator. For detailed engine operation and maintenance information, always refer to the engine section of this manual.

Powerhorse is constantly improving its products. The specifications outlined herein are subject to change without prior notice or obligation. The purchaser and/or user shall assume liability for any modification and/or alterations of this equipment from original design and manufacture.

Before using, the user shall determine the suitability of this product for its intended use and assumes liability therein.

Contact Powerhorse Product Support at 1-866-443-2576 for any questions about the appropriate use of this generator.

Warranty Registration

Please fill in the warranty registration information and have it on hand when you call in on a warranty claim or replacement parts.

ATTENTION:

All Rental Companies and Private Owners who loan this equipment to others!

All persons to whom you rent/loan this generator must have access to and read this manual. Keep this owner's manual with the generator at all times and advise all persons who will operate the machine to read it. You must also provide personal instruction on how to safely operate the generator and remain available to answer any questions a renter/borrower might have.

Specifications

Item Number	#6075636
Maximum Output	
Gasoline	27,000Watts(W)
Propane	24,300Watts (W)
Continuous Output:	
Gasoline	18,000 Watts (W)
Propane	16,200 Watts (W)
Voltage	120/240 Volt (V)
Phase	Single phase (4-wire)
Frequency	60±1Hertz (Hz)
Power Factor	1.0 p.f.
Total Harmonic Distortion	less than 5%
Run Time at 50% Load	8 Hours
Engine	999cc
Engine Speed	3600 RPM
Fuel Type	Unleaded gasoline (minimum 87 octane)
Fuel Capacity	17 gallons (64.3 L)
Oil Capacity	2.6 US quarts (2.5 L)
Starting Method	Electric Start
Spark Plug	F6RTC
Spark Plug Torque	14.75 – 18.43 Ft Lbs. (20-25 N m)
120/240 Volt Receptacles	4 - 20 Amp 120V GFCI receptacles (NEMA 5-20R) 2 – 30 Amp 120V locking (NEMA L5-30R) 1 – 30 Amp 120/240V locking (NEMA L14-30R) 1 – 50 Amp 120/240V straight blade (NEMA 14-50R)
12 Volt DC Receptacle	1 – 8 Amp 12V
AC Circuit Breakers	2 - 20 Amp (A) thermal, push to reset 2 - 30 Amp (A) thermal, push to reset 1 - 30 Amp (A) 2-Pole, toggle to reset 1 - 50 Amp (A) 2-Pole, toggle to reset 1 - 75 Amp (A) 2-Pole, toggle to reset
DC Circuit Breaker	1 - 8 Amp (A) thermal, push to reset
Dimensions	
Length	37.79 in.
Width	35.15 in.
Height	37.79 in.
Dry Weight	510 lbs.
Battery Specs	12 Volt DC
(Battery Included)	Sealed Lead Acid 36Ah or greater rating Terminal Type – M6 bolt 10.24" (L) x 5.39" (W) x 0.98" (H) (w/terminals)

Safety Label Locations

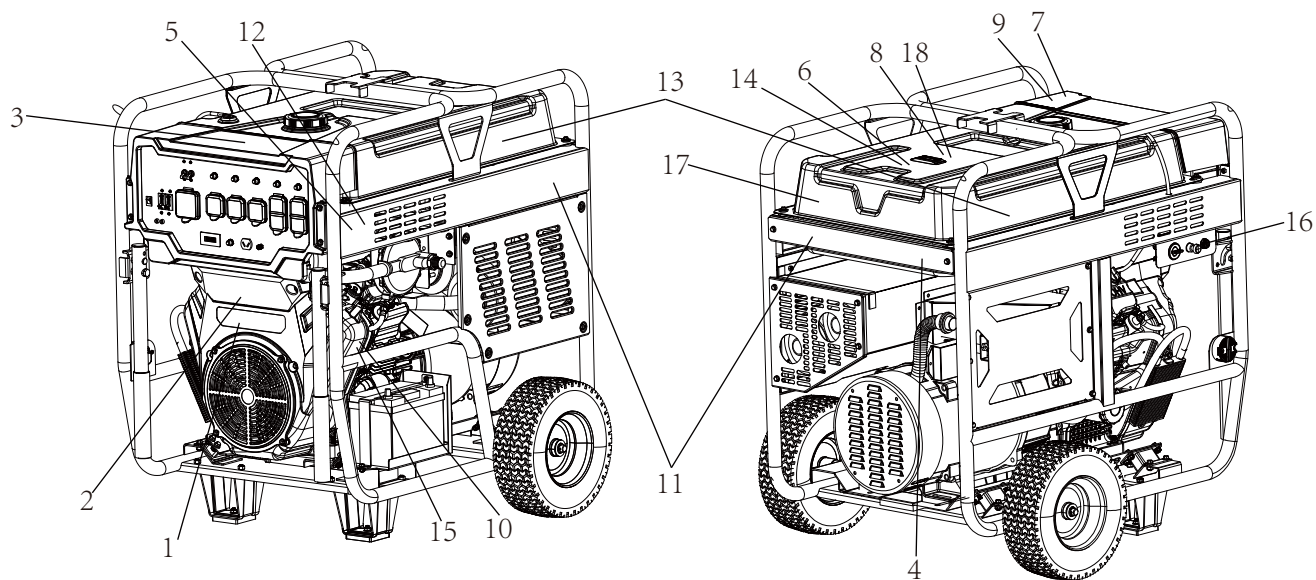

Ref#	Part #	Description	Qty
1	PH6075636.D1	Engine Displacement Decal	1
2	PH6075636.D2	Air Filter Decal	1
3	PH6075636.D3	Top Branding Decal	1
4	PHGNSID1	Starting Instruction Decal	1
5	PH6075636.D5	Improper Connection Decal	1
6	PHGNSFD	Shock/Fire Decal	1
7	PHGNED	Ethanol Decal	1
8	PHGNCPCSD	CPSC Decal	1
9	PHGNFOW	Fire & Overheating Warning	1
10	PH6075636.D10	27000W Nameplate	1
11	PHGNBWD2	Burn Warning Decal	2
12	PHGNBWD1	Battery Warning Decal	1
13	PH6075636.D13	Powerhorse Model Decal	2
14	PHGNCOBWD	CO Battery Warning Decal	1
15	PH6075636.D15	EPA Decal	1
16	PH6075636.D16	Switch Decal	1
17	NA	Starting Decal	1
18	NA	CO Warning Decal	1
19	NA	QR Code Decal	1

Always make sure safety labels are in place and in good condition. If a safety label is missing or not legible, order new labels or unsafe operation could result.

To order replacement safety labels, call Powerhorse Product Support at 1-866-443-2576.

Machine Component Identification

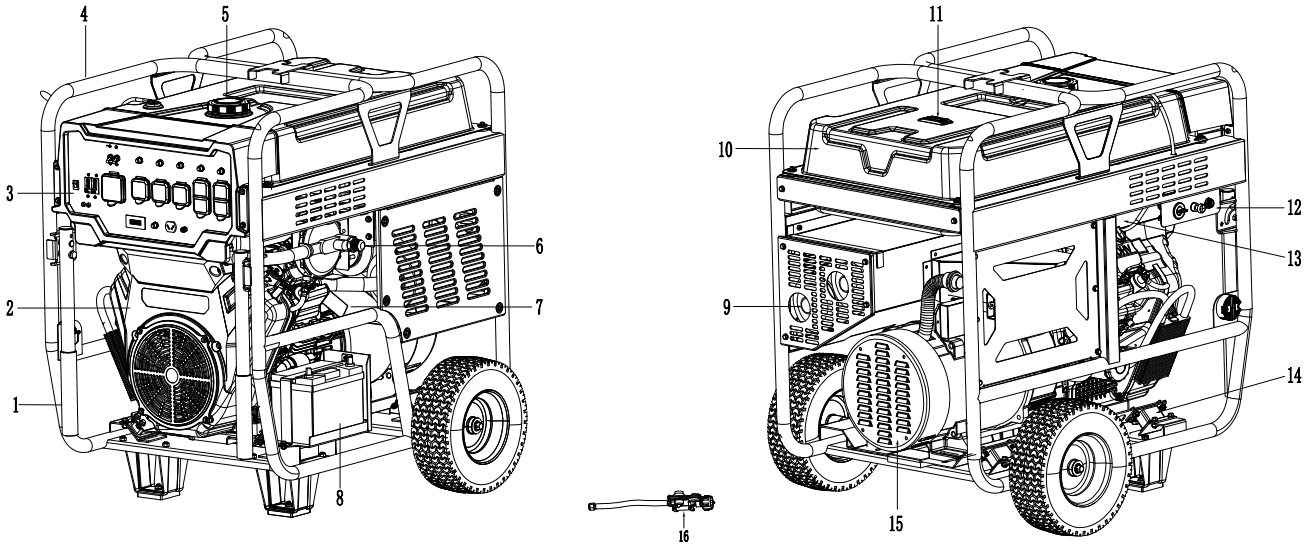

Reference	Description	Reference	Description	Reference	Description
1	Handle	7	Oil Level Dipstick	13	Air Filter Assembly
2	Engine (999cc)	8	Battery	14	Vibration Isolation Mount
3	Control Panel	9	Muffler	15	Generator Head
4	Roll Cage Frame	10	Gas Tank	16	Propane Hose Assembly
5	Gas Cap	11	Fuel Gauge		
6	Low Pressure Regulator	12	Engine Control Panel		

Reference Guide

Reference 1 - Handle	Provides a means for moving the generator. To move generator, pivot handle up and secure using the handle pin.
Reference 2 - Engine (999cc)	Internal combustion spark ignited engine.
Reference 3 - Control Panel	An electrical device that contains receptacles, switches and other electrical devices.
Reference 4 - Roll Cage Frame	Provides protection for the generator.
Reference 5 - Gas Cap	The gas cap is extra-large, creating a large hole for refilling and has a comfortable grip.
Reference 6 - Low Pressure Regulator	Device that smooths the flow of propane. It is not a pressure reducing regulator.
Reference 7 - Oil Level Dipstick	Dipstick for checking engine oil level.
Reference 8 - Battery	Storage location for the battery (battery included).
Reference 9 - Muffler	An acoustic device installed onto the exhaust system that is designed to reduce noise. The muffler outlet also includes spark arresters.
Reference 10 - Gas Tank	A large tank that allows for extended run capabilities. ALWAYS allow room for gasoline expansion by not filling the gas tank completely.
Reference 11 - Fuel Gauge	Fuel level indicator for gas tank.
Reference 12 - Engine Control Panel	Fuel Switch is the ON / OFF valve to control the fuel flow into the engine. ALWAYS keep valve OFF when the generator is not in use or during transportation. Choke Knob is the device that is pulled out to restrict the flow of air into the carburetor when starting a cold engine. Engine Switch is the ON / OFF / START switch for power to electric start the engine.
Reference 13 - Air Filter Assembly	Filter element that removes particles from incoming air. See the engine section of this manual for maintenance and replacement.
Reference 14 - Vibration Isolation Mount	The engine and generator head are mounted on rubber mounts that absorb most of the engine vibration. This feature eliminates the tendency of the machine to "walk" while engine is running.
Reference 15 - Generator Head	The electricity producing part of the generator.
Reference 16 - Propane Hose Assembly	Pressure reducing regulator/hose assembly that connects propane tank fuel supply to low pressure regulator.

Machine Component Identification

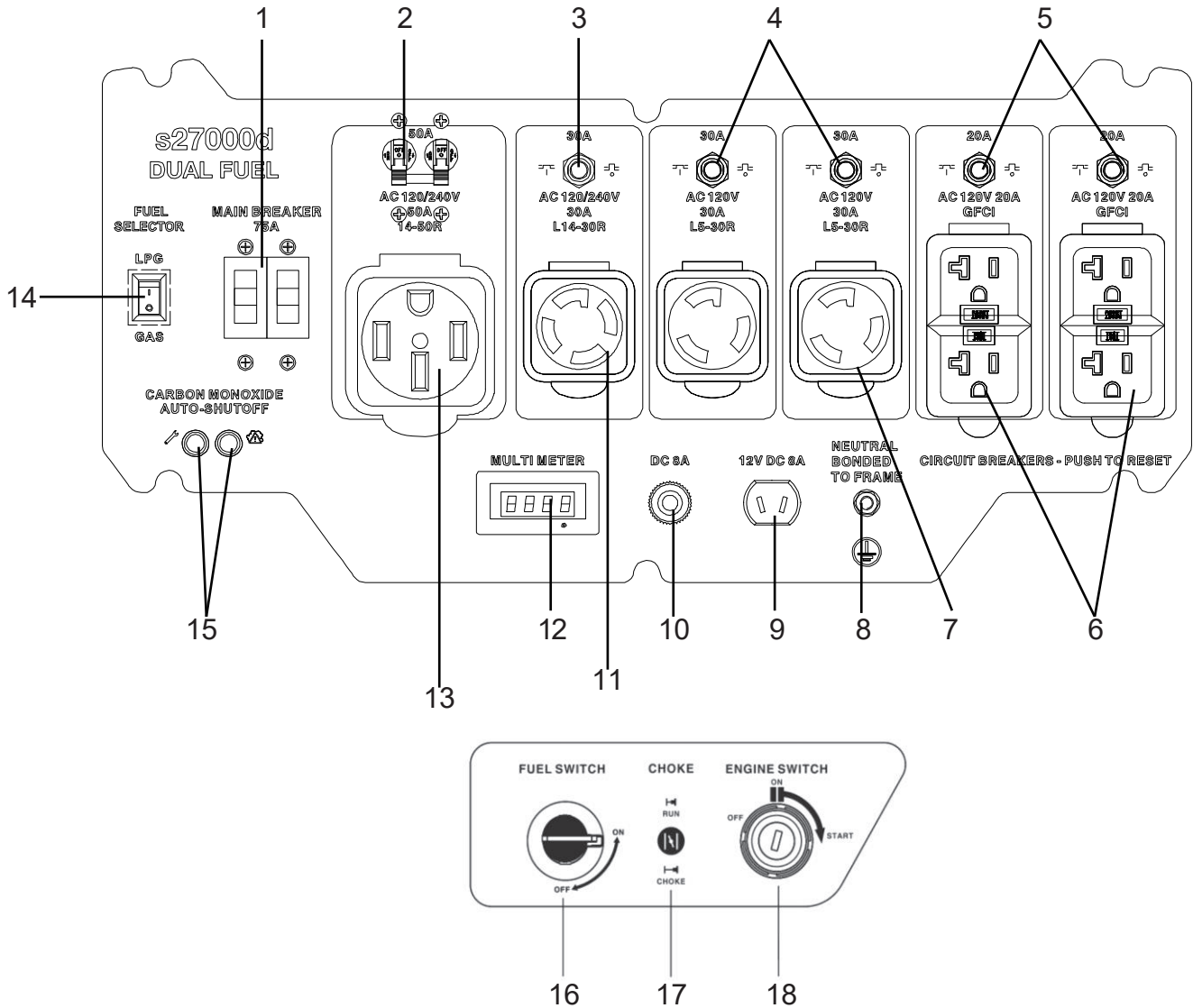

Ref. No.	Description	Qty.
1	Main Circuit Breaker, 75A	1
2	Circuit Breaker, 50A	1
3	Circuit Breaker, 2P- 30A	1
4	Circuit Breaker, 30A	2
5	Circuit Breaker, 20A	2
6	120V, 20A GFCI Duplex Receptacle (NEMA -20R)	4
7	120V, 30A Locking Receptacle (NEMA L5-30R)	2
8	Grounding Post	1
9	12V DC, 8A Receptacle	1
10	Circuit Breaker, 8A, 12V DC	1
11	120/240V, 30A Locking Receptacle (NEMA L14-30R)	1
12	Multimeter	1
13	120/240V, 50A Straight Blade Receptacle (NEMA 14-50R)	1
14	Fuel Selector Switch	1
15	CO Sensor Light	2
16	Fuel Switch (ON/OFF)	1
17	Choke Knob	1
18	Engine Switch (OFF/ON/START)	1

Machine Component Identification

Using the Multimeter

Multimeter (Meter-V-F-T) will display the operating status of the generator.

1. Toggle through the display by manually pressing the MODE button.
 - V = Voltage display (shown as UXXX - actual voltage is XXX)
 - F = Frequency display (shown as FXX,X - actual frequency is XX,X)
 - T = Cumulative Time display (shown as XXXX - the total run time in hours is XXXX)
 - Run Time display (shown XX:XX - actual each use run time in hours and minutes is XX:XX)
2. Remind function displays:
 - Displays as P 25 (first 25 hours) change oil
 - Displays as P 50 (first 50 hours) clean air filter
 - Displays as P 100 (first 100 hours) change/clean the fuel filter, clean air filter, and change the oil
3. Reset function works by pressing the MODE button 3 times quickly (within 0.5 seconds) to reset Cumulative Time and Run Time.

MULTI METER

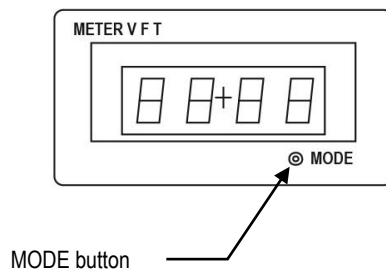

Note: The Run Time will reset to 00:00 each time the generator is turned off.

Installation / Initial Set-Up (continued)

There are a number of important steps required to set up your generator for initial use. These steps are:

Steps for Installation / Initial Set-Up

1. Unpacking & delivery inspection.
2. Planning the power load to stay within the generator's rated capacity.
3. Propane hook-up.
4. Setting up generator for the type of power generation you need:
 - a. portable power source, or
 - b. connect to a building as a back-up power source.
5. Selecting a site for using the generator.
6. Grounding the generator.
7. Battery installation.
8. Wheel kit assembly.
9. Propane tank connection.

Each of these steps is discussed in detail below:

1. Unpacking & Delivery Inspection

You should inspect the generator immediately after you receive delivery.

See the Machine Component Identification section of this manual for a diagram of the generator and its components.

- If you are *missing* or have damaged components, contact Product Support at 1-866-443-2576.

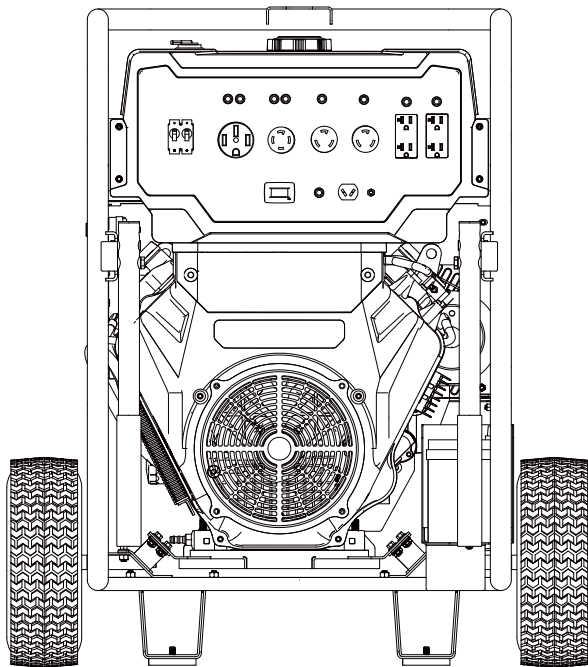

Generator Unit

12V DC Charging Cables
Part # 800993
(for use with 12V DC outlet on control panel)

Part # 801009
Funnel

Axle (Qty 2)
Part# PH6075636.29

Cotter Pin (Qty 4)
Part#PHCOTTPIN1

Wheel (Qty 2)
Part#PH6075636.8

Installation / Initial Set-Up (continued)

2. Planning the Power Load

Plan your power load so that you do not exceed the generator's rated capacity.

▲ WARNING

- NEVER exceed the rated wattage capacity of your generator.
- OVERLOADING may cause SERIOUS DAMAGE to the generator and attached electrical devices, and may result in fire.

Your generator **MUST BE SIZED PROPERLY** to provide both the running and starting (surge) wattage of the devices you will be powering. Before using your generator, determine the running and starting wattage requirements of all the electrical devices you will be powering simultaneously. The sum of the running and starting wattages of the devices being powered must not exceed the continuous output rating of your generator. (The continuous output rating of your generator is listed in the Specifications section of this manual.) Note that:

- Devices without electric motors such as light bulbs, radios, and televisions have the same running and starting wattage.
- Devices with electric motors such as refrigerators, compressors, and hand tools typically require a starting wattage that is 3 to 5 times greater than the running wattage.

The running and starting wattage requirements are often listed on a device's nameplate. If wattage is not given on the device's nameplate, the wattage may be calculated by multiplying the nameplate voltage by nameplate amperage, $\text{Watts} = \text{Volts} \times \text{Amps}$.

Example conversion to watts:

$$120 \text{ Volts} \times 5 \text{ Amps} = 600 \text{ Watts}$$

If only the running voltage is given on the nameplate for a device with an electric motor, the starting wattage can be approximated to be three to five times the running wattage.

Estimates for the running wattage requirements for common devices are listed in **Table 1** below. Guidance for starting wattages is provided in the table's footnotes.

Table 1

Device	Running Watts	Device	Running Watts
Air conditioner (12,000 BTU)	1700 (a,b)	Jet pump	800 (a)
Battery charger (20 Amp)	500	Lawn mower	1200
Belt sander (3")	1000	Light bulb (100 Watt)	100
Chain saw	1200	Microwave oven	700
Circular saw (6½")	2000 (a,b)	Milk cooler	1100 (a)
Coffee maker	1800 (a,b)	Oil burner on furnace	300
Compressor (1 HP)	1400 (a,b)	Oil-fired space heater (140,000 Btu)	400
Compressor (¾ HP)	1800 (a)	Oil-fired space heater (85,000 Btu)	225
Compressor (½ HP)	1400 (a)	Oil-fired space heater (30,000 Btu)	150
Curling iron	700	Oven	4500
Dishwasher	1200	Paint sprayer, airless (1/3 HP)	600 (a)
Edge trimmer	500	Paint sprayer, airless (handheld)	150

Installation / Initial Set-Up (continued)

Device	Running Watts	Device	Running Watts
Electric nail gun	1200	Refrigerator	600 (b)
Electric range (1 element)	1500	Slow cooker	200
Electric skillet	1250	Submersible pump (1-1/2 HP)	2800 (a)
Furnace fan (1/3 HP)	1200 (a)	Submersible pump (1 HP)	2000 (a)
Freezer	800 (b)	Submersible pump (1/2 HP)	1500 (a)
Hair dryer	1200	Sump pump	600 (a)
Hand drill (1")	1100	Table saw	2000 (a)
Hand drill (1/2")	875	Television	500
Hand drill (3/8")	500	Toaster	1000
Hand drill (1/4")	250	Vacuum cleaner	250
Hedge trimmer	450	VCR	70
Home computer	150	Water heater	3000
Impact wrench	500	Weed trimmer	500
Radio	200		

(a) Hard-starting motors require 3-5 times the rated running watts.

(b) For extremely hard to start loads such as air conditioners and air compressors, consult the equipment dealer to determine maximum wattage.

To calculate the running and starting wattage requirements for the devices you will be powering, follow these steps:

1. Make a list of all electrical devices you will be powering at the same time with the generator.
2. List the greater of the running or starting wattage next to each device as obtained from the devices' nameplate or **Table 1**. If only the running wattage for a device with an electric motor is known, the starting wattage can be estimated to be at least 3 times the running wattage.
3. Add the wattages for all devices on your list. This total must be lower than the continuous output rating of your generator.

Example:

Device to be Powered	Greater of Starting/Running Wattage
Light bulb	75 W
Refrigerator – 18 cu. ft.	1600 W
Microwave	700 W
Window AC	1800 W
Sump pump (1/3 hp)	2100 W
Total	6275W

In this example, the generator must have a continuous output of at least 6275 W in order to power all of the devices simultaneously.

STAGGERING LOADS

You can increase the number of devices your generator can power by staggering the load on the generator. For example, you could alternately power your refrigerator and air conditioner for limited periods of time -- powering only one of the devices at a time and never powering both at the same time.

Installation / Initial Set-Up (continued)

3. Propane Hook-up

You can power this generator with gasoline or propane. The generator is designed so that it is easy to switch between fuel sources. However, there are special initial hook-up requirements for propane.

WARNING

Propane is a highly explosive gas. A qualified propane technician must make the valve and hose connection between the propane tank and generator in accordance with all federal and local requirements. All propane hook-ups should be completed by a certified propane technician from a propane supplier and inspected as required by your local building code.

This product is designed to operate at a propane pressure range of 7" to 11" of water column and requires a minimum gas flow rate of 4.6 lbs./hr.

Note: All propane tanks produce gas pressure in excess of 11" water column. Introduction of gas pressure into the generator in excess of 11" water column will permanently damage this product and void the warranty. This generator includes a supply hose with a pressure-reducing regulator that needs to be installed as part of your propane fuel system.

You will need a minimum 100 lb. propane tank to operate the generator.

Some installations may require tanks even larger than 100 lb. as a result of low surrounding air temperature and other appliances drawing fuel from the same tank.

When transporting, always keep the propane tank in the upright position with the valve turned off. Always position the propane tank to ensure that the supply hose between the propane tank and regulator does not bend or kink.

WARNING

Contact with liquid contents of the propane tank will cause freeze burns on the skin.

Installation / Initial Set-Up (continued)

4. Setting Up as Building Back-up or Portable Power Source

This generator is designed to provide up to 18,000 watts of total electrical power. This generator is capable of providing 12,000 watts (240V/50Amps) of electrical power from a single receptacle NEMA 14-50R. This generator can supply electricity in two ways:

1. **As a back-up, standby power source for a building.** For this application, you must arrange for a licensed electrician to connect the generator to your building's electrical system via the installation of an UL-listed transfer switch. The transfer switch must be installed in accordance with building electrical code and guidelines supplied by your power company.
2. **As a portable power source.** You can plug appliances or tools directly into the generator's electrical outlets.

Specific requirements for each are given below.

Note: Regardless of whether you use your generator as a back-up power source connected to a building or as a portable power source, you must not overload the generator. Overloading may cause serious damage to the generator and attached electrical devices.

Using as a back-up power source for a building

Contact a licensed electrician to install a UL-listed transfer switch if you want to use your generator as a back-up power source for a building.

What does a transfer switch do?

- a) Safely connects the generator to your building's electrical system by isolating your generator from your utility company's power lines,
- b) Connects your generator to a critical subset of your building's circuits that are needed for emergency power needs.

If your generator will be connected to your building's electrical system, it **MUST ALWAYS** be isolated from the utility power grid with a *UL-listed transfer switch installed by a licensed electrician* in compliance with all applicable building and electrical codes, and in accordance with guidelines supplied by your power company.

⚠ DANGER: A transfer switch must be installed in order to isolate your generator from the utility power grid. If your generator is NOT properly isolated from the utility system, serious hazards will arise:

- When your generator is running, its output will back feed into the utility power line and transformer that are normally used to provide you with power. The transformer will step up the current to the normal line voltage. An unsuspecting utility line worker working on what he thinks is a deactivated line could be electrocuted.
- If your generator is connected (running or not) when utility power is restored, your generator will be destroyed. It could also explode or cause fire.

In addition to isolating your generator from the utility system, the transfer switch connects your generator to a limited set of circuits in your building that have been chosen as critical to operate during a power outage.

The generator cannot power your entire home -- you must work with the installing electrician to determine which devices/appliances you wish to power during an outage. The electrician can help you determine which circuits and devices can be powered simultaneously without overloading the generator.

(See the previous section of this manual entitled "**Planning the Power Load**" for more information on load application and selection.)

Installation / Initial Set-Up (continued)

Using as a portable power source

When using the generator as a portable power source, you can plug electric devices and appliances directly into the generator's electrical outlets.

There are eleven different electrical outlets on the generator:

1. One 120/240 Volt, 50 Amp Straight Blade receptacle (NEMA 14-50R compatible with NEMA 14-50P mating plugs).
2. One 120/240 Volt, 30 Amp Locking receptacle (NEMA L14-30R compatible with NEMA L5-30P mating plugs).
3. Two 120 Volt, 30 Amp Locking receptacles (NEMA L5-30R compatible with NEMA L14-30P mating plugs).
4. Four 120 Volt, 20 Amp GFCI duplex receptacles .
5. One 12 Volt DC 8 Amp receptacle.

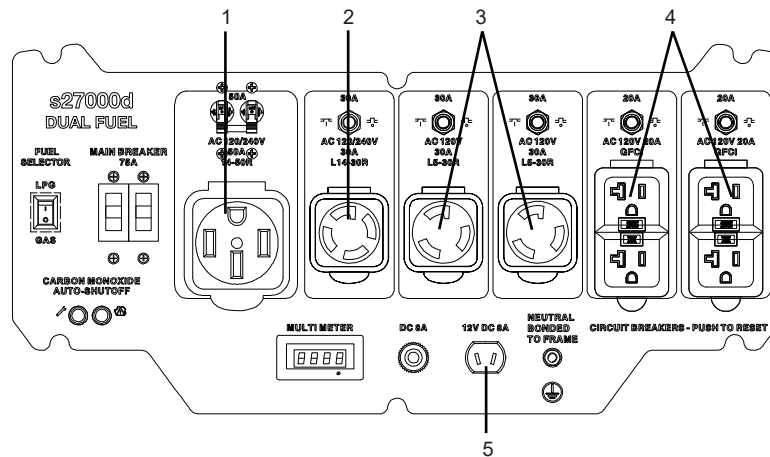

- Make sure you plug each electrical device/appliance into the correct generator outlet based on the device's plug configuration and voltage/amperage rating. Never exceed the amperage rating of an outlet.
- Extension cords may be used to power devices that are located at a distance from the generator. However, use only UL-listed, outdoor-rated, grounded extension cords of the proper size. Use Table 2 below to choose an adequately sized extension cord according to the amperage of the device being used and the length of the cord.

Table 2

Current/Power		Maximum Extension Cord Length			
Amps at 240V	Load (watts)	#10 Ga. Cord	#12 Ga. Cord	#14 Ga. Cord	#16 Ga. Cord
10	2400	250'	150'	100'	75'
20	4800	125'	75'	50'	25'
30	7200	60'	35'	25'	10'
40	9600	30'	15'	10'	*
50	12000	15'	*	*	*

⚠ WARNING: Use of undersized extension cords can cause electric shock, fire, or damage to connected devices.

Installation / Initial Set-Up (continued)

- All extension and appliance cords must be in good condition and not worn, bare, frayed, or otherwise damaged.

⚠ WARNING: Use of damaged electric cords can cause electric shock or fire.

Note: If an extension cord becomes hot to the touch, it is overloaded or damaged and must be replaced. Northern Tool is NOT responsible for damage or injury resulting from customer use of inadequate extension cords.

5. Select a Suitable Site

Before using the generator, you must select a suitable **OUTDOOR** location for installation and operation. This location should meet all of the criteria listed below.

⚠ WARNING: You must choose a suitable site for operating your generator to avoid equipment damage and/or injury and possible death from carbon monoxide poisoning, electric shock, or fire. Choose a site that meets all of the criteria specified.

Dry, level surface

The generator should be positioned on a dry, firm, level surface.

Ensure that the generator sits level and will not slide or shift during operation. If applicable, block the generator's wheels to prevent sliding and shifting.

Outdoors only – dangerous carbon monoxide exhaust

⚠ WARNING: The exhaust from your generator contains carbon monoxide (CO), a poisonous gas that can kill. You cannot smell it, see it, or taste it. *Carbon monoxide exhaust is given off whether you are using gasoline, natural gas, or propane as the fuel source to power the generator.* Follow the directions below for choosing a location to operate your generator in order to avoid carbon monoxide poisoning.

The location you choose to operate the generator must be OUTDOORS and away from all air intakes:

- Never run the generator inside any closed or semi-enclosed spaces (even if outdoors), including homes, garages, basements, sheds, or boxes. *These spaces can trap poisonous gases, even if you run a fan or open windows.*
- Place the generator so that the exhaust fumes will not be directed towards people or building air intakes.
- Ensure that working, battery-operated or battery back-up carbon monoxide alarms are used in any dwelling/structure that is in close proximity to the running generator.
- Note that this generator is NOT designed or approved for use in vehicles or marine applications. Never run the generator inside RVs or other vehicles, on boats, or on pick-up truck beds.

⚠ WARNING: Never attempt to attach ductwork to the muffler system to allow for installation inside an enclosure. This could cause hot air deflection, heat build-up, and increased exhaust back-pressure, resulting in possible exhaust leakage or damage to the generator.

Adequate cooling ventilation

The generator needs adequate, unobstructed flow of air to allow for proper cooling of engine and generator head.

⚠ WARNING: Heat build-up from inadequate ventilation can result in fire, posing a serious risk to nearby persons and structures.

- Situate so there is adequate clearance around generator to allow for cooling airflow so that heat does not build up.

Installation / Initial Set-Up (continued)

	<ul style="list-style-type: none"> • Never place the generator immediately adjacent to a building or other structure – allow at least 7 feet clearance. • DO NOT run the generator in close proximity to other heat-generating equipment, such as another generator. The combined heat that is generated may raise air temperature in the immediate area and there will not be adequate cooling ventilation. • DO NOT allow debris to accumulate and block airflow. • DO NOT operate with a tarp, blanket, or cover surrounding the generator.
No wet conditions	<p>Choose a location where the generator will NOT be exposed to rain, snow, or direct sunlight. Exposure to water can cause electric shock.</p> <p>You may operate the generator under an outdoor, canopy-like structure of heat-resistant material that is open on all sides. Make sure that all parts of canopy are at least 7 feet from exhaust, and allow for adequate clearance above generator so that heat does not build up.</p>
Hot exhaust clearance	<p>The exhaust gas from your generator is extremely hot and can cause combustible materials to catch on fire.</p> <ul style="list-style-type: none"> • Make sure your generator’s exhaust system is at least 7 feet from all combustible materials and buildings/structures. • The engine is equipped with a spark arrester if the generator will be used near any ignitable forest, brush, or grassy land. Make sure you comply with applicable local, state, and federal codes. • Keep a fire extinguisher rated “ABC” nearby. Keep it properly charged and be familiar with its use.
Away from dust/dirt	<p>DO NOT use the generator in extremely dusty or dirty conditions. Excessive dust and dirt can cause premature failure of the machine.</p>
Hearing protection	<p>Generators can produce noise levels in excess of 95 dB in close proximity, which can be dangerous to human hearing with prolonged exposure.</p> <p>Hearing protection may be required for persons working within 15-20 feet of the running generator for an extended period of time.</p> <p>⚠ WARNING: Never attempt to attach ductwork to the muffler system to lower noise levels. This could cause hot air deflection, heat build-up, and increased exhaust back-pressure, resulting in possible exhaust leakage or damage to the generator.</p>

Installation / Initial Set-Up (continued)

6. Grounding the Generator

Always ensure the generator is properly grounded to prevent electrical shock.

You must always ground the generator by the following method when using the generator as a portable electrical source:

1. Drive a 3/4" or 1" copper pipe or rod into the ground close to the generator. The pipe/rod must penetrate moist earth – the depth required will be dictated by local soil conditions. Consult with an electrician.
2. Connect an approved ground clamp to the pipe.
3. Run a 8-gauge wire from the clamp to the generator grounding post which is located on the base of the generator frame to the right of the battery location.
4. DO NOT connect the generator grounding post to a water pipe or a ground used by a radio system.

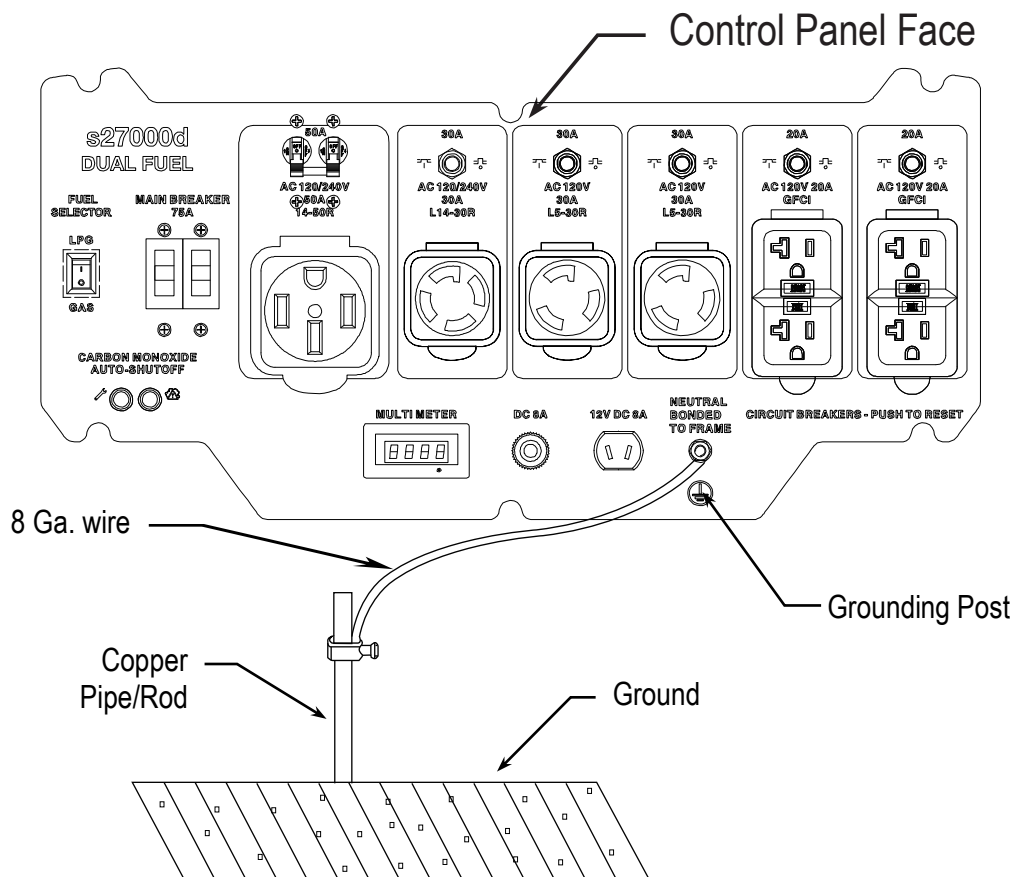

If a licensed electrician installs the generator with a connection to your building's electrical circuit for use as a back-up power system, grounding may alternatively be completed through the building's grounding system. Ask your electrician. If the generator is not grounded through your building's electrical system, follow the procedure above.

⚠ WARNING: Operating the generator when it is not properly grounded can result in electrical shock.

Installation / Initial Set-Up (continued)

7. Battery Installation

Your generator's engine is equipped with an electric starter which requires the installation of a 12-volt DC battery. See the Specifications section of this manual for more specific battery requirements for this generator model, such as minimum amperage or CCA rating.

The battery is supplied with the generator. Ensure the battery is securely installed in the battery tray with the battery insulator and the holder. The orientation of the battery should be with the terminals towards the front. Follow the instructions detailed below for connecting and disconnecting the battery.

See the Specification section of the manual for battery information.

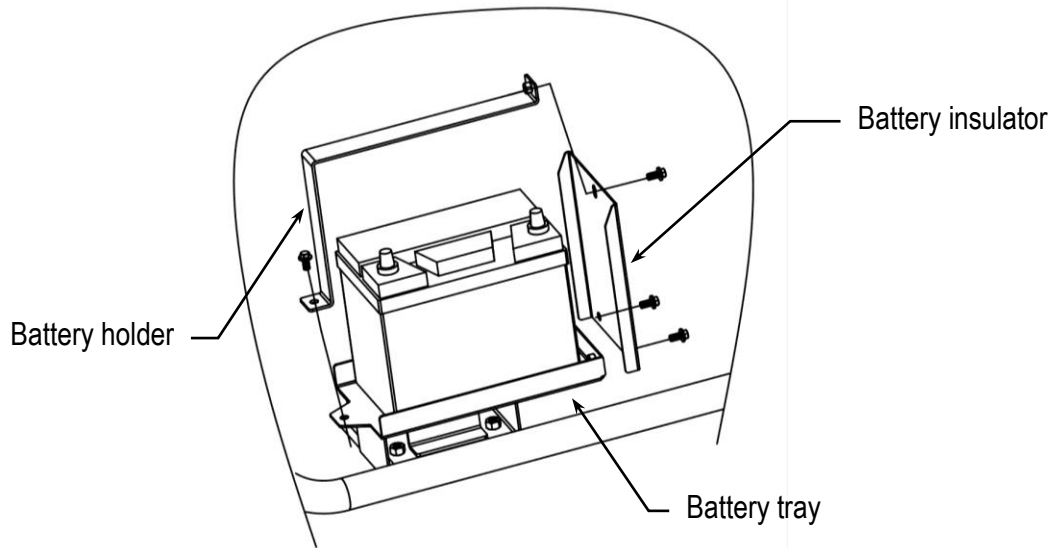

⚠ WARNING: Batteries are hazardous because they contain caustic acid, can emit explosive gases, and can cause electric shock. Caution must be exercised when making connections to a battery to avoid shock and contact with the acid, and to prevent any sparking that could lead to an explosion. ALWAYS follow the general battery safety rules and instructions listed below.

General battery safety rules	<ul style="list-style-type: none"> • ALWAYS use eye protection when handling batteries. • NEVER smoke or work near sparks or other sources of ignition. • NEVER touch both battery terminals at the same time with your hand or any non-insulated tools. • If battery acid contacts skin or clothing, flush immediately with water and neutralize with baking soda.
Connecting the battery	<p>Always connect the cables in the following sequence to avoid possible shock:</p> <ol style="list-style-type: none"> 1. Find the battery cables located near the battery tray. 2. Connect the red cable to the positive (+) terminal of the battery. 3. Then connect the black cable to the negative (-) terminal of the battery.
Disconnecting the battery	<p>Always disconnect cables in the following sequence to avoid possible shock.</p> <ol style="list-style-type: none"> 1. First, disconnect the black cable from the negative (-) terminal of the battery. 2. Next, disconnect the red cable from the positive (+) terminal of the battery.

Installation / Initial Set-Up (continued)

8. Wheel Kit Assembly

Your generator is equipped with a free wheel kit to provide easy portability.

Secure the generator on blocks at least 7" off the ground or work table. Make sure the holes in the base of the generator are not obstructed to allow for installation of axle and wheels.

Installing the axle and wheels

1. Slide the smaller diameter side of (1) Axle into the Frame Hole.
2. Insert (1) Cotter Pin into the holes on that end of the Frame to secure the Axle.
3. Slide (1) Wheel onto the larger diameter side of Axle in the orientation shown.
4. Insert (1) Cotter Pin into the holes on the other end of the Axle to secure the Wheel.
5. Repeat for the opposite Wheel.

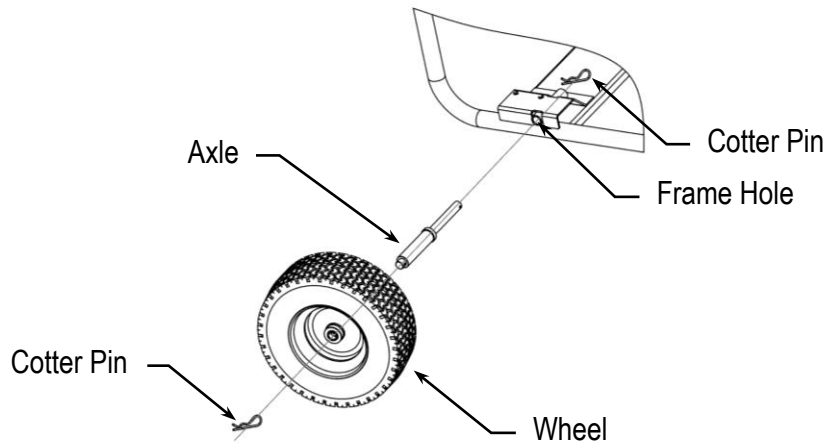

Attach handle pin to generator frame

1. Attach lanyard to pin.
2. Attach lanyard and pin to generator frame by looping the rope around the tube and inserting the pin through the loop.
3. Lift the handle as shown and insert the pin into the hole in handle bracket.

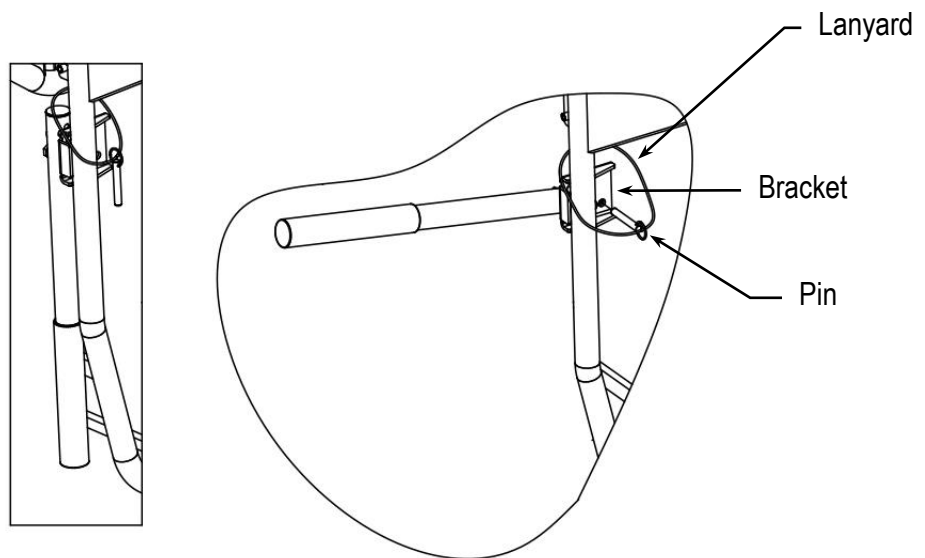

Installation / Initial Set-Up (continued)

9. Propane Tank Connection

Your generator is equipped with a 4.92 ft. propane hose assembly that connects your propane tank (not included) to the low pressure regulator on the generator. The pressure reducing regulator also ensures that the proper fuel pressure of 7 – 11 inches of water column is being supplied to the low pressure regulator on the generator.

Position tank and attach 4.92 ft. propane hose assembly

1. Thread end of hose with pressure reducing regulator onto the propane tank valve.
2. Thread remaining hose end into the bottom port on the low pressure regulator.

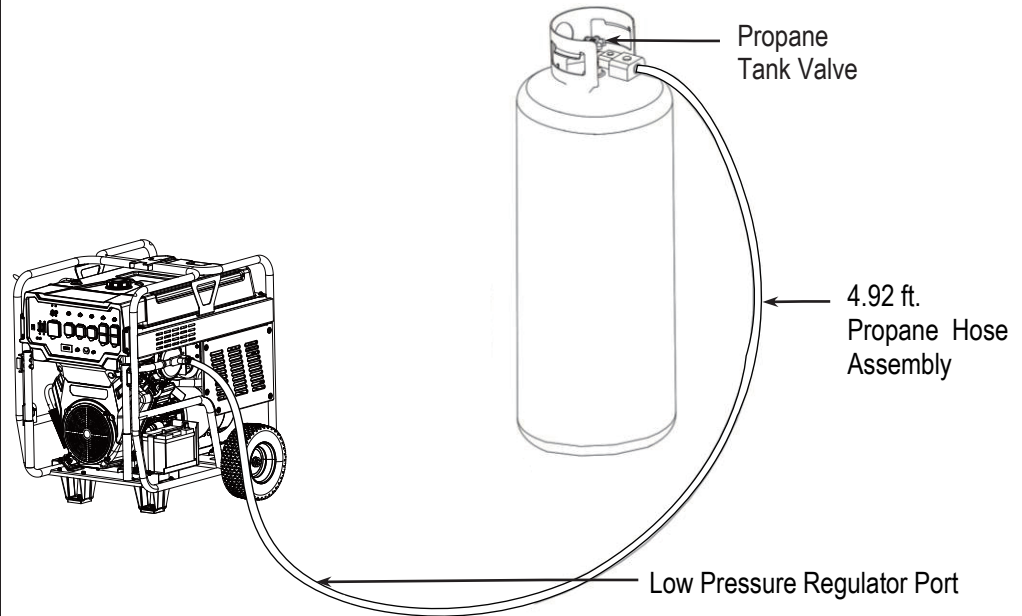

Operation

DATA CENTER

Push the mode button to cycle through the data display modes.

Voltage: Displays current voltage output.

Frequency (Hz): Displays power output frequency in Hertz.

Lifetime Hours: Displays the lifetime run hours.

Run Time/Maintenance: Displays current run time. Resets to zero when shut down. Maintenance reminder displayed when required.

Maintenance Codes:

P25 – Change engine oil.

P50 – Clean air filter, Change engine oil.

P100 – Change engine oil, clean air filter, replace fuel filter.

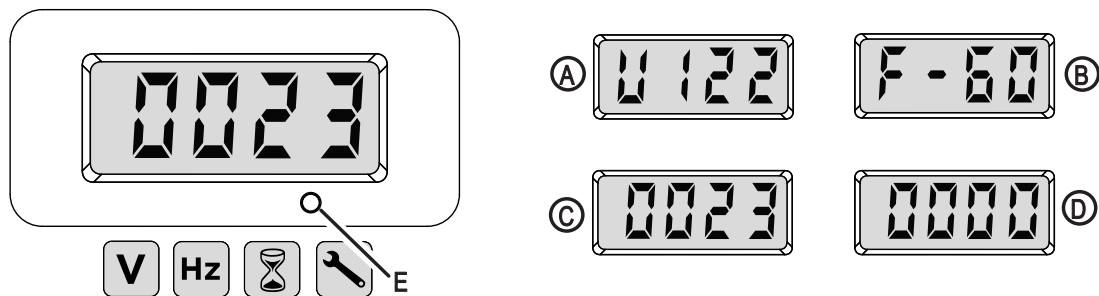

A - Voltage

B - Frequency

C - Lifetime Hours

D - Run Time/Maintenance Reminder

E - Mode Button

CO Sentry

The CO Sentry system was created to protect from dangerous carbon monoxide. Just like the detector for your home the CO Sentry tests the air for dangerous levels of carbon monoxide. If dangerous levels of carbon monoxide are detected this generator will automatically shut off.

⚠ WARNING : Automatic shut off accompanied with a flashing RED light in the CO Sentry portion of the control panel is an indication that the generator was improperly located. If you start to feel sick, dizzy, weak, or carbon monoxide detectors in your home indicate an alarm, get to fresh air immediately. Call emergency services. You may have carbon monoxide poisoning.

CO Sentry Indicator Lights

RED

Carbon monoxide has accumulated around the generator. After shut off, the RED indicator light in the CO Sentry area of the control panel will flash to provide notification that the generator was shut off due to an accumulating CO hazard. The RED light will flash for at least five minutes after a CO shut off. Move the generator to an open, outdoor area far away from occupied spaces with exhaust pointed away. Once relocated to a safe area, the generator can be restarted. Introduce fresh air and ventilate the area where the generator had shut down.

YELLOW

A CO Sentry system fault occurred. When a system fault occurs, the generator is automatically shut down and the YELLOW indicator light in the CO auto shut off area of the control panel will flash to provide notification that a fault has occurred. The YELLOW light will flash for at least five minutes after a fault. The generator can be re-started, but may continue to shut off.

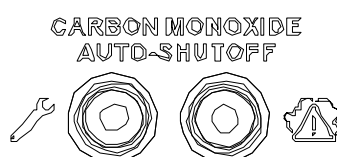

Operation

Once you have set up your generator for use, it is time to start your generator. The following are the procedures necessary for safe, successful operation of your generator.

Operation Procedures

1. **General Safety Rules for Operation**
2. **Preparing for Operation**
3. **Starting the Engine**
4. **Checking Generator Output**
5. **Connecting Electrical Loads (Portable Power Generation)**
6. **Stopping the Engine**
7. **Storage & Exercise of Generator**

Each of these procedures is discussed in detail below:

1. General safety rules for operation

Before starting the generator, review the following general safety rules for operation:

⚠ WARNING: Failure to follow safety rules may result in serious injury or death to the operator or bystanders.

- **Know proper use/how to stop.** Be thoroughly familiar with proper use of the equipment and all generator controls, output receptacles, and connections. Know how to stop the generator quickly if needed. (See step 6 the Operation section, Stopping the Engine.)
- **Instruct operators.** The generator owner must instruct all operators in safe generator set-up and operation. Only trained adults should set up and operate the generator – DO NOT let children operate.
- **Intended use.** Carefully read about and understand the intended use of this generator. DO NOT use for other purposes, as unforeseen hazards or equipment damage may result.
- **Under the influence.** Never operate, or let anyone else operate, the generator while under the influence of alcohol, drugs, or medication.
- **Safety equipment / controls.** DO NOT operate the generator unless all safety covers, guards, and barriers are in place and in good working order, and all controls are properly adjusted for safe operation.
- **Damaged.** DO NOT operate the generator with damaged, missing, or broken parts.
- **Modifications.** DO NOT modify the generator in any way. Modifications can create serious safety hazards and will also void the warranty.
- **Engine speed.** Never attempt to modify the engine speed setting. The engine speed is preset at 3600 RPM for safe and optimal performance of the generator. If speed needs adjusting, it must be done by factory-authorized personnel.
- **External fuel sources.** Never attempt to connect external gasoline/diesel sources in order to increase engine run time. Larger tank at pressure or higher elevation will cause gasoline to leak from carburetor during operation. Fire or explosion could result.

Operation (continued)

⚠ WARNING: Failure to follow safety rules may result in serious injury or death to the operator or bystanders.

- **Malfunction during operation.** Immediately turn off the generator if any of the following conditions arise during operation:
 - Excessive change in engine speed, slow or fast
 - Overheating in load connecting devices
 - Sparking or arcs from generator
 - Loss of electrical output
 - Receptacle damage
 - Engine misfire
 - Excessive vibration
 - Flame or smoke
 - Abnormal noise
- **Adjusting / repairing.** Always turn off generator and remove spark plug(s) or spark plug wire(s) before working on the generator to prevent accidental starting. Always discharge the capacitor before working on the generator head to prevent electrical shock. (See Maintenance & Repair section of this manual for instructions on how to do this.)
- **Carbon monoxide poisoning.** The running engine gives off carbon monoxide, a poisonous gas that can kill you. You CANNOT smell it, see it, or taste it. Follow all instructions for site selection and positioning the generator, and avoid inhaling the exhaust. If you start to feel sick, dizzy, or weak while using the generator, shut off the engine and get to fresh air RIGHT AWAY. See a doctor. You may have carbon monoxide poisoning.
- **Other exhaust dangers.** This product contains or emits chemicals known to the State of California to cause cancer, birth defects or other reproductive harm. Avoid inhalation of exhaust.
- **Wet conditions.** DO NOT operate the generator or handle any electrical equipment while standing in water, while barefoot, while hands are wet or while in the rain or snow. Electric shock may result.
- **Ground fault circuit interrupter.** Always use a ground fault circuit interrupter (GFCI) protected extension cord (or outlet, if generator is equipped) in damp or highly electrical conductive areas and on construction jobsites to prevent electrical shock.
- **Avoid contact.** Avoid contact with bare wires, terminals, connections, etc., while the unit is running.
- **Electric shock accident.** If an electric shock accident occurs, immediately shut down the source of electrical power. If this is not possible, attempt to free the victim from the live conductor. Avoid direct contact with victim. Use a nonconducting implement, such as a dry rope or board, to free the victim from the live conductor. Apply first aid and get immediate medical help.
- **Smoking/sparks.** Never smoke near the running generator, and never operate near sources of sparks or flames.
- **Hot muffler.** Never touch a hot muffler, hot exhaust manifold, or engine cooling fins. Exhaust and engine parts can be very hot and will burn you.
- **Moving parts.** Keep hands, feet, and apparel away from drive belts, fans, and other moving parts. Never remove any drive belt or fan guard while the unit is operating.
- **Proper maintenance.** Improper maintenance or failure to correct a problem before operation can cause a malfunction in which you can be seriously hurt or killed. **ALWAYS** perform a pre-operation inspection before each operation, and correct any problems. **ALWAYS** follow the inspection and maintenance recommendations and schedules in this owner's manual.

Operation (continued)

Static electricity and filling the gasoline tank:

Static electricity can initiate from ungrounded gasoline tanks or containers, from flowing gasoline, and from persons carrying a static electric charge.

Static electricity can explosively ignite gasoline vapors that are present during the fueling process, resulting in serious burns to nearby persons. To avoid static electricity while fueling, certain steps must be followed before and during the fueling process in order to minimize and safely dissipate static charge build-up:

- **Touch a grounded metal object before starting.** Always dissipate static charge from your body before beginning the fueling process by touching a grounded metal object at a safe distance away from fuel sources.
- **Use a portable container to fill tank.** Never fill the generator's gas tank directly from the fuel pump – the generator's tank is not grounded and the high velocity flow of gasoline from a fuel pump can cause static electric build-up. Use an approved portable container to transfer gasoline to the generator's tank.
- **Fill container on the ground.** Never fill the portable gas container while it is sitting inside a vehicle, trailer, trunk, or pick-up truck bed. ALWAYS place container on the ground to be filled.
- **Keep nozzle in contact with container.** Keep nozzle in contact with the portable container at all times while filling. Manually control the flow of gasoline; DO NOT use the nozzle's lock-open device.
- **Use a portable container made of metal or conductive plastic.** It will dissipate the charge to ground more readily.

About static electricity and fueling

Many common objects can accumulate and retain a static electric charge. Objects made of non-conductive materials (e.g. plastics) easily accumulate and retain static electric charge, as can objects made of conductive material (e.g. metal, water) if they are not electrically grounded. The static electric charge on an object, such as a human body or plastic fuel tank/container, can reach as high as several thousand volts!

A static electric spark can be generated if the static electric charge stored on an object "jumps" to another, less charged object. Such a spark can ignite invisible gasoline vapors that are present during fueling situations.

Typical sources of static electric hazards during fueling

The following objects can accumulate a static electric charge and cause an ignition spark in typical fueling situations:

1. Ungrounded tanks/containers. Any ungrounded fuel tank or container can accumulate a static electric charge as a result of contact with other objects or friction during transportation. This static electricity can discharge as a spark to the grounded gasoline dispenser nozzle, as the nozzle is first brought close to the tank/container at the beginning of the fueling process.
2. Flowing gasoline. Most people are not aware that gasoline accumulates static electric charge while flowing through a hose or pipe. This charge then transfers to and accumulates in the gas tank or container that is being filled. The total amount of charge accumulation depends on the amount of gas pumped into the container, the speed with which it is pumped, and whether or not the tank/container is grounded. If sufficient static electric charge accumulates in the fuel tank or container during the fueling process, the tank/container may discharge a spark to the grounded gasoline dispenser nozzle.
3. Persons. A person dispensing the gasoline can carry a static electric charge on their body, typically resulting from contact with their car seat or electronics. The static electricity can discharge as a spark between that person's hand and either the grounded dispenser nozzle or the fuel tank opening.

Operation (continued)

2. Preparing for Operation

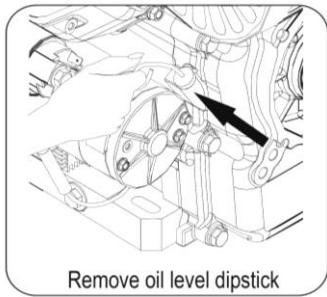
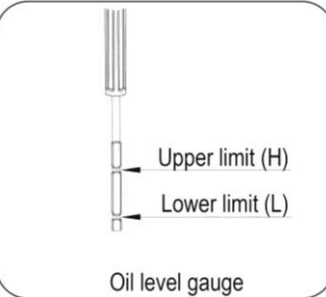
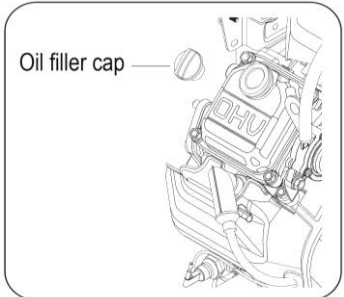
Position generator	<p>Position generator in accordance with the instructions given in “Installation & Initial Set-up, Step 4: Select a Suitable Site” of this manual.</p> <p>Operate outside only, on dry, level ground with adequate clearance and ventilation.</p> <p>⚠ WARNING: Generators give off carbon monoxide exhaust, a poisonous gas that can kill. You CANNOT smell it, see it, or taste it. ONLY run generator OUTDOORS and away from air intakes. NEVER run generator inside any enclosed or semi-enclosed spaces, including homes, garages, basements, sheds, boxes, pick-up truck beds, RVs, or boats. These spaces can trap poisonous gases, EVEN if you run a fan or open windows. <i>Carbon monoxide exhaust is given off whether you are using gasoline, natural gas, or propane to power the generator.</i></p>
Ground generator	<p>Make sure the generator is grounded in accordance with instruction given in step 5 of the Installation & Initial Set-up section, Grounding the Generator.</p> <p>⚠ WARNING: Always ensure generator is properly grounded to prevent electrical shock.</p>
Perform scheduled maintenance as needed	<p>Make sure that any regular maintenance has been performed as prescribed in this manual in the Maintenance & Repair section.</p> <ol style="list-style-type: none"> 1. Refer to the engine section of this manual for engine maintenance instructions. 2. Make sure battery is charged. Charge as needed according to your battery manufacturer’s instructions.
Check/add oil	<p>Check the oil level and add oil as needed.</p> <p>Remove oil level dipstick and check oil level using below oil level gauge. Remove oil filler cap, add recommended oil using provided funnel, and recheck oil level.</p> <div style="display: flex; justify-content: space-around; align-items: flex-end;"> <div style="text-align: center;">  <p>Remove oil level dipstick</p> </div> <div style="text-align: center;">  <p>Oil level gauge</p> </div> <div style="text-align: center;">  <p>Oil filler cap</p> </div> </div> <p>(See engine section for oil type and capacity, and more detailed oil check/fill instructions.)</p> <p>⚠ WARNING: Never open oil port while engine is running. Hot oil can spray over face and body.</p> <p>Notes:</p> <ul style="list-style-type: none"> • Low oil pressure shutdown feature prevents the generator from starting without sufficient oil pressure. • Engine is shipped <u>without</u> oil. You must add oil before first use. <p>IMPORTANT:</p> <p>Under long, continuous-run operating conditions, be prepared to:</p> <ul style="list-style-type: none"> • Check engine oil level every time you refuel the engine. • Change oil after the first 25 operating hours, and at least every 25 operating hours thereafter, or as directed in engine section of this manual.

Operation (continued)

Check/fill gasoline tank

Check the gasoline level in the generator's tank using the fuel gauge. If needed, fill tank with fresh UNLEADED gasoline from a portable container, after first reading the warnings and instructions below.

⚠ WARNING: Gasoline is highly flammable and explosive. Heat, sparks, and flames can ignite gasoline vapors, which can become widespread during fueling. A flash fire and/or explosion could result and cause serious injury or death. Use extreme care when handling gasoline. Carefully follow all the instructions in this section to avoid the following conditions which could result in gasoline ignition:

- gas vapor collection inside enclosures
- static electric sparks
- sparks from electric wiring, batteries, or running engines
- sources of heat (such as a hot engine or exhaust)
- open flames, including pilot lights

1. Before starting, review the following general safety precautions for fueling:
 - a. Never pump gasoline directly into the generator's gas tank at a gas station – high velocity flow from the pump could result in a static electric build-up in the generator's tank. Always use a portable container to fill the tank. *See warning section about static electric spark hazards below.*
 - b. Fill gasoline tank OUTDOORS – never indoors.
 - c. Stay away from all sources of heat, sparks, and flames. DO NOT smoke.
 - d. DO NOT use fuel containing more than 10% ethanol.

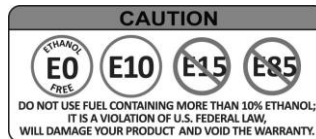

2. Turn generator engine off and allow to cool for at least two minutes before removing gas cap.

NOTICE: A running or still-hot engine is hot enough to ignite fuel.

3. Remove generator gasoline cap.
4. Add gasoline through the fill opening:
 - Use only a UL-listed portable gasoline container to transfer the gasoline to the generator's tank. Follow the safety warning and instructions below to avoiding static electric sparking.
 - DO NOT overfill the gasoline tank. Allow at least 1/2 inch of empty space below the fill neck to allow for fuel expansion.

Gasoline Fill Opening

Fuel Gauge

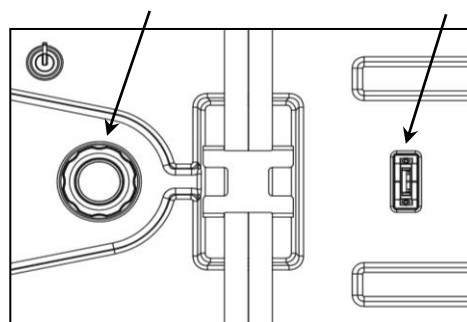

DO NOT overfill fuel tank.

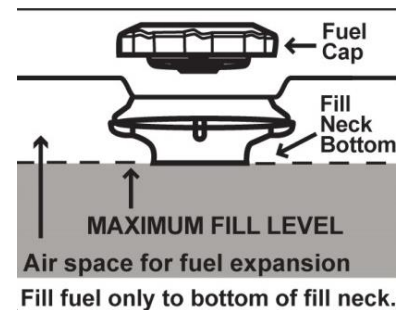

Operation (continued)

⚠ WARNING: A static electric spark can explosively ignite gasoline vapor, resulting in a flash fire that could cause serious injury or death.

To avoid static electric sparking while filling the gasoline tank, **the following steps must be followed to minimize and safely dissipate static electric charge build-up before and during the fueling process:**

- Always dissipate static charge from your body before beginning the fueling process by touching a grounded metal object at a safe distance from fuel sources.
 - Never fill the generator's gas tank directly from the fuel pump – the generator's tank is not grounded and high velocity flow from the pump can cause static electricity build-up. Use an approved portable container to transfer gas to the generator's tank.
 - Never fill the portable gas container while it is sitting inside a vehicle, trailer, trunk, or pick-up truck bed. ALWAYS place container on the ground to be filled.
 - Keep nozzle in contact with portable container while filling. Manually control the flow of gasoline; DO NOT use the nozzle's lock-open device.
 - A portable container made of metal or conductive plastic is preferred because it dissipates charge to ground more readily.
5. Clean up gasoline spills /splashes immediately.
 - a) If possible, move the generator away from spilled gasoline on the ground.
 - b) Wipe up spilled gasoline, and wait 5 minutes for excess gasoline to evaporate before starting engine.
 - c) Gasoline soaked rags are flammable and should be disposed of properly.
 - d) If gasoline is spilled on your skin or clothes, change clothes and wash skin immediately.
 6. Replace gasoline cap securely before starting engine.
 7. Store extra gasoline in a cool, dry place in an UL-listed, tightly sealed container.

IMPORTANT:

For continuous operation, be prepared to check and refuel the engine on a regular basis. A tank of gasoline should last about 8 hours under 50% load.

Inspect fuel system / check for leaks

Inspect fuel system & check for leaks BEFORE starting generator.
DO NOT start generator until all needed repairs have been completed.

Personal protection

1. Hearing can be damaged from prolonged, close-range exposure to the type of noise produced by this generator. **The use of ear plugs or other hearing protection device is recommended** for persons working within 15-20 feet of the running generator for an extended period of time.
2. Loose or dangling apparel can become entangled in moving parts. Metal jewelry can conduct electricity. Never wear jewelry or loose-fitting clothing when starting or operating the generator.

Operation (continued)

3. Starting the Engine

After you have completed the pre-start checklist procedures, you are ready to start the engine.

To start the engine:

- 1) Disconnect all loads to the generator.
- 2) Turn the FUEL SWITCH to the ON position.
- 3) For cold engine, pull CHOKE knob out to the full choke position. To restart a warm engine, push the CHOKE knob to the half choke position or to the RUN position.
- 4) Start the engine:
 - i) Turn the key in the ENGINE SWITCH to the START position and hold it there until the engine starts.
 - (a) *NOTE: If the engine fails to start after 5 seconds, release key and wait 10 seconds before attempting to start again. Cranking the electric starter for more than 15 seconds continuously can overheat and damage the starter motor. If engine fails to start, wait for 1 minute to re-start.*
 - ii) Release the key when the engine starts.
- 5) When engine starts, allow engine to warm up and then move CHOKE knob to RUN position.
- 6) Under long, continuous-run operating conditions, be prepared to:
 - a) Check and refuel the engine on a regular basis. A tank of gas should last about 8 hours under 50% load.

⚠ WARNING: A running engine is hot enough to ignite fuel. Never add fuel or remove gas cap if engine is running or still hot. Let cool at least 2 minutes.
 - b) Check engine oil level each time you refuel.
 - c) Change oil after the first 25 operating hours, and at least every 25 operating hours thereafter, as directed in the engine owner's manual.

⚠ WARNING: Never open oil port while engine is running. Hot oil can spray over face and body.

Operation (continued)

4. Checking Generator Output

Although the speed of the engine was carefully adjusted at the factory so that the generator produces the proper voltage and frequency, **output voltage should be checked periodically to ensure the generator is working properly before connecting loads to the generator.**

⚠ WARNING: The generator must be run at the correct speed in order to produce the proper electrical voltage and frequency. Failure to do so could result in damage to equipment powered by the generator and possible injury to the individual.

Output voltage can be checked at the voltmeter on the control panel or can be checked with a portable voltage meter:

1. Start engine and allow to warm up for 5 minutes. DO NOT connect any loads.
2. Use data meter on control panel to check generator output or use a voltage meter to check output voltage at the generator's outlets/receptacles.
3. Measured voltage should be within the following ranges:
 - a) 120V +/- 10% at 120V receptacles
 - b) 240V +/- 10% at 240V receptacles
4. If measured voltage is not within the specified range, have generator adjusted by factory authorized personnel. DO NOT attempt to adjust the engine speed yourself.

Note:
Slight variation in voltage/speed with changing electrical loads

All engines have a tendency to slow down when a load is applied. When electrical loads are connected to the generator, the engine is more heavily loaded and as a result the speed drops slightly.

This slight decrease in speed, together with the voltage drop within the generator itself, results in a slightly lower voltage when the generator is loaded to its full capacity than when it is running with no load. Additionally, there may be small brief surges and drops in voltage as motors connected to the generator cycle on or off.

The slight variation has no appreciable effect in the operation of motors, lights, and most appliances.

Operation (continued)

5. Connecting Electrical Loads

You will want to be careful when connecting loads so as not to overload the generator, especially if you are powering devices with motors that require a higher starting power load.

Instructions are provided below for connecting loads when you are using the generator:

- As a portable power source
- Connected to a building as a back-up power source

⚠ WARNING: DO NOT overload generator. Make sure that combined starting and running loads do not exceed rated capacity of generator. Overloading the generator can cause damage to the generator and attached electrical devices, and may result in fire.

Using as a portable power source

Connect electrical loads one at a time according to the following instructions:

1. Allow engine to reach operating speed by allowing it to warm up for approximately 5 minutes before connecting electrical devices.
2. After engine is warmed up, begin by connecting the items that require the highest wattage first. The recommended sequence is as follows:
 - a) Connect items with motors such as refrigerators, freezers, air conditioners, or small hand tools, one at a time. Let each motor stabilize before connecting the next device.
 - b) Connect any lights you are planning on powering.

Connect voltage-sensitive equipment such as electronics via surge protectors. Plug devices such as TVs, computers, and microwaves into a UL-listed voltage surge protector, then plug the surge protector into the generator.

Using as a back-up power source for a building

Each transfer switch installation will be unique.

Proper instructions for how to safely bring the generator online with the building's electrical system should be provided by the installing electrician, who should also provide personal instruction to the owner/operator.

Failure to follow the proper procedure as provided by the electrician could expose persons to the hazards noted above.

6. Stopping the Engine

Stop the engine using the following steps:

1. Disconnect all loads to the generator.
2. Turn key in Engine Switch to OFF position.
3. Turn Fuel Switch to OFF position.

Remove key from starter to prevent accidental starting of engine.

⚠ WARNING: Let generator cool for at least five minutes before moving or storing. A hot generator can be a fire hazard. Generator and engine surface temperature is still hot after shutdown.

Operation (continued)

7. Storage & Exercise

When you are finished using the generator, you must:

- Disconnect all loads
- Shut off fuel supply
- Store the generator properly
- Plan on exercising the engine regularly unless the generator is prepared for long-term storage

Detailed instructions are provided below.

Disconnect loads & turn off fuel switch	<p>When you are finished using the generator, disconnect all loads and turn off fuel switch:</p> <ol style="list-style-type: none"> 1. Make sure all devices that were connected to the generator's outlets have been disconnected. 2. Check to be sure Fuel Switch is in OFF position.
Cool engine before storing	<p>Let engine cool for at least five minutes before storing. A hot engine can be a fire hazard.</p>
Choose a storage location	<p>Store the generator in a location that is:</p> <ul style="list-style-type: none"> • Clean and dry. • Away from sources of heat, open flames, sparks, or pilot lights, even if the generator's fuel tank is empty. Residual fuel in the tank could ignite. • Away from extreme high or low temperatures. <p>Note: DO NOT store with a battery charger always connected. Batteries that are over-charged can boil themselves dry and produce excessive amounts of hydrogen, an explosive gas.</p>
Prevent accidental starting	<p>Remove key from starter and secure key in a safe location, and/or remove spark plug(s) in order to ensure the generator cannot be started accidentally in a storage location or by untrained persons.</p>
Exercise generator every 4 weeks	<p>The generator should be exercised regularly.</p> <p>At least every four weeks, start the engine and let it run for 10 to 15 minutes with a small load plugged in, such as a lamp or fan.</p> <p>Monthly exercising of the generator will:</p> <ul style="list-style-type: none"> • Dry out any moisture that has accumulated in the windings. If left, this moisture can cause corrosion in the winding. • Ensure that the unit is operating properly should it be needed in an emergency.
Perform regular maintenance	<p>Perform periodic maintenance as directed in the Maintenance and Repair section of this manual to keep the generator in safe working condition.</p>

Maintenance & Repair

Inspect and maintain your generator as specified below in order to keep it in safe and optimal working order. Follow all safety rules and recommended maintenance steps.

⚠ WARNING

ALWAYS shut off the engine, disconnect the spark plug(s) before cleaning, adjusting, or servicing the generator. Make sure all guards and shields are replaced before using.

NOTICE: The generator head is a brush style and requires maintenance. The bearing is a heavy-duty sealed ball bearing which requires no maintenance or lubrication.

Maintenance & Repair	
Follow safety rules	<p>Read and follow these safety rules whenever you will be servicing the generator:</p> <ul style="list-style-type: none"> • Turn off generator. Always turn off generator and remove spark plug(s) or spark plug wire(s) before working on the engine or generator to prevent accidental starting. • Replace guards. Make sure all guards and shields are replaced after servicing the generator. • Repair. Major service, including the installation or replacement of parts, should be performed only by a qualified electrical service technician. Obtain factory approved parts from Powerhorse Product Support at 1-866-443-2576. • Replacement parts. If a part needs replacement, only use factory approved repair parts. Replacement parts that do not meet specifications may result in a safety hazard or poor operation of the generator and will void the warranty. • Transporting. Ensure the engine switch is OFF. Ensure the fuel switch is OFF. DO NOT leave generator inside an enclosed vehicle for an extended period of time and/or operate the generator while inside a vehicle. See moving and lifting instructions below.
Perform engine maintenance	<p>Perform engine maintenance as specified in the Engine section of this manual.</p> <p>Engine maintenance items include:</p> <ol style="list-style-type: none"> 1. Changing oil and oil filter 2. Air filter check/replacement 3. Spark plug cleaning and replacement 4. Fuel filter check/replacement 5. Fuel tank cleaning 6. Clean and inspect spark arrester
Check receptacles	<p>Check receptacles before each use to make sure they are not cracked or broken.</p> <p>If a receptacle is cracked or otherwise damaged, DO NOT use until replaced with an authorized factory part. Using cracked or damaged receptacles can be both dangerous to the operator and destructive to the equipment.</p>
Inspect fuel system / check for leaks	<p>Inspect the fuel system and check for leaks on a regular basis.</p> <p>Inspect the entire fuel system. Look for: signs of leaks or deterioration, chafed or spongy fuel hose, loose connections, loose or missing fuel hose clamps, damaged gasoline tank, or defective fuel switch.</p>

Maintenance & Repair (continued)

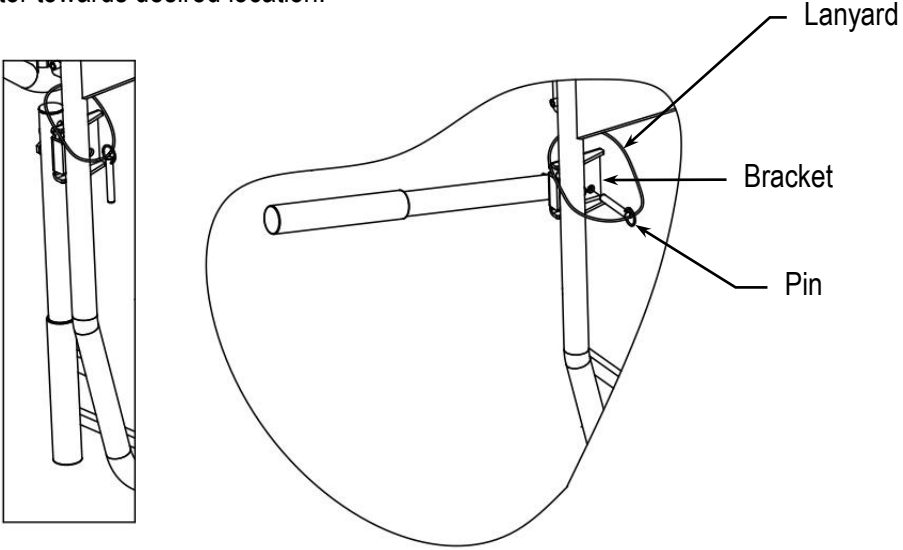
<p>Keep generator clean</p>	<p>Keep generator clean. If dust or debris accumulates on the generator, clean the generator with a damp cloth or soft bristle brush. DO NOT allow air intakes to become blocked. Note: DO NOT spray generator with a garden hose or pressure washer. Water may enter the generator and cause damage to the rotor, stator, or internal windings.</p>
<p>Recharge and maintain battery</p>	<p>Inspect, recharge, and maintain your battery according to your battery manufacturer's instructions. (Only for those models equipped with electric start.) DO NOT store with battery charger always connected. Batteries that are over-charged can boil themselves dry and produce excessive amounts of hydrogen, an explosive gas.</p>
<p>Moving and lifting generator</p>	<p><u>Moving:</u> The wheel kit and handle provide an easy method for moving the generator. Pivot the handle up and secure using the handle pin. Lift recoil end of generator to roll generator towards desired location.</p> <div style="text-align: center;">  </div> <p>⚠ WARNING: The generator is heavy. You can be injured when trying to lift it without assistance. It can crush and cause serious injury if it drops on someone. Follow the instructions below for safely lifting the generator.</p> <p><u>Lifting:</u> To reduce risk of injury, team lift or use a hoist to elevate/lower the generator. Secure appropriately sized lifting chains and/or tie straps to the generator.</p>

IMPORTANT: If a part needs replacement, only use parts that meet the manufacturer's specifications. Replacement parts that do not meet specifications may result in a safety hazard or poor operation of the generator.

Contact Powerhorse Product Support at 1-866-443-2576 for any questions, problems, or parts orders.

Troubleshooting

TROUBLESHOOTING		
<u>Problem</u>	<u>Possible Causes</u>	<u>Possible Remedies</u>
Engine will not start.	<ul style="list-style-type: none"> a) Low oil pressure. b) Fouled spark plug. c) Out of fuel. d) Engine switch in OFF position. e) Fuel switch in OFF position. f) Choke is in OPEN position. g) Battery not charged. h) Bad fuel. i) Fuel filter restricted. j) Carburetor malfunctioning. k) Ignition malfunctioning. l) Inlet and Outlet valves stuck. 	<ul style="list-style-type: none"> a) Fill crankcase to proper oil level. b) Clean or replace spark plug. c) Fill fuel tank. d) Place engine switch in ON position. e) Turn fuel switch to ON position. f) Move choke lever to CLOSED (cold engine only). g) Recharge battery. h) Drain fuel and refuel. i) Clean or replace filter. j) Clean or replace carburetor. k) Replace ignition switch. l) Check and adjust valve clearance.
Voltage too low.	<ul style="list-style-type: none"> a) Engine speed too slow. b) Generator is overloaded. 	<ul style="list-style-type: none"> a) Bring generator to a qualified technician for adjustment. b) Reduce the load (see Power Load Planning & Mgt. section of manual).
Circuit breaker trips.	<ul style="list-style-type: none"> a) Defective load connected to generator. b) Defective receptacle. c) Generator overloaded. 	<ul style="list-style-type: none"> a) Disconnect load. b) Replace receptacle. c) Reduce the load (see Power Load Planning & Mgt. section of manual).
Voltage too high.	<ul style="list-style-type: none"> a) Engine speed too high. 	<ul style="list-style-type: none"> a) Bring generator to a qualified technician for adjustment.
Generator overheating.	<ul style="list-style-type: none"> a) Generator is overloaded. b) Insufficient ventilation. 	<ul style="list-style-type: none"> a) Reduce the load (see Power Load Planning & Mgt. section of manual). b) Make sure there is at least 7 feet of clearance on all sides of generator.
No output voltage.	<ul style="list-style-type: none"> a) Defective load connected to generator. b) Broken or loose wire. c) Defective receptacle. d) Defective stator. e) Defective rotor. f) Circuit breaker tripped. 	<ul style="list-style-type: none"> a) Disconnect load. b) Bring generator to a qualified technician for repair. c) Replace receptacle. d) Bring generator to a qualified technician for repair. e) Bring generator to a qualified technician for repair. f) Reset circuit breaker and reduce loads connected to the generator.
Engine lacks power.	<ul style="list-style-type: none"> a) Generator is overloaded. b) Dirty air filter. c) Bad fuel. d) Fuel filter restricted. e) Carburetor malfunctioning. f) Ignition malfunctioning. g) Inlet and Outlet valves stuck. h) Spark arrester clogged. 	<ul style="list-style-type: none"> a) Reduce the load (see Power Load Planning & Mgt. section of manual). b) Clean or replace air filter. c) Drain fuel and refuel. d) Clean or replace filter. e) Clean or replace carburetor. f) Replace ignition switch. g) Check and adjust valve clearance. h) Clean screen or replace spark arrester.
Engine shuts down during operation.	<ul style="list-style-type: none"> a) Out of fuel. b) Low oil pressure. 	<ul style="list-style-type: none"> a) Fill fuel tank. b) Fill crankcase to proper oil level.

Summary of Important Safety Information for Operation

This section provides a summary of the various safety procedures and measures that have been presented throughout the manual. Keep this summary handy and refer to it to refresh your memory about how to safely use your generator.

⚠ WARNING

Carefully read and make sure you understand the following safety information before using the generator. Improper use or maintenance of the generator can result in **serious injury or death** from **carbon monoxide poisoning, electric shock, fire/explosion, or burns**.

General

- **Read manual.** Read this owner's manual and the engine owner's manual completely before attempting to set-up and use the generator. Serious injury or death can result if safety instructions are not followed.
- **Instruct operators.** The generator owner must instruct all operators in safe generator set-up and operation. DO NOT allow anyone to operate the generator who has not read the Owner's Manual and been instructed on its safe use.
- **Adults only.** Only trained adults should set up and operate the generator. DO NOT let children operate.
- **Under the influence.** Never operate, or let anyone else operate, the generator while under the influence of alcohol, drugs, or medication.
- **Intended use.** Carefully read about and understand the intended use of this generator. DO NOT use for other purposes, as unforeseen hazards or equipment damage may result.

Prohibition Against Modifications

Never modify or alter the generator in any way. Modifications can create serious safety hazards and will also void the warranty.

- **Engine speed.** Never attempt to modify the engine speed setting. The engine speed is preset at 3600 RPM for safe and optimal performance of the generator. If speed needs adjusting, it must be done by factory-authorized personnel.
- **Fuel/exhaust system.** Never modify the exhaust system, fuel tanks, or fuel lines. Carbon monoxide poisoning, fire, or explosion could result.
- **Guards.** DO NOT operate generator unless all guards and cover shields, which prevent access to moving parts and pinch points, are in place. Failure to guard the power transmission mechanisms **may result in serious injury or death**.

Safety – Installation & Set-up

Battery Safety

Batteries are hazardous because they contain caustic acid, can emit explosive gases, and can cause electric shock. *Caution must be exercised when making connections to a battery to avoid shock and contact with the acid, and to prevent any sparking that could lead to an explosion.* Follow safety rules carefully when connecting battery to generator:

- **Eye/skin protection.** Always wear eye protection and protective clothing when connecting or disconnecting battery.
- **Sparks/smoking.** Never smoke or work near sparks or other sources of ignition.
- **Electric shock.** Never touch both battery terminals at the same time with your hand or any non-insulated tools.
- **Connection/disconnection sequence.** ALWAYS connect and disconnect cables to the correct battery terminals in the proper sequence:
 - When CONNECTING the battery, connect the RED cable to the POSITIVE terminal FIRST.
 - When DISCONNECTING the battery, disconnect the BLACK cable from the NEGATIVE terminal FIRST.
- **Acid/skin contact.** If battery acid contacts skin or clothing, flush immediately with water and neutralize with baking soda.

Installation / Initial Set-up Safety

- **Dry, level surface.** Situate generator on a dry, firm, level surface. Ensure generator sits level and will not slide or shift during operation. Block wheels if applicable.
- **Operate OUTSIDE only – dangerous carbon monoxide exhaust!** Generators give off carbon monoxide exhaust, a poisonous gas that can kill. You CANNOT smell it, see it, or taste it. ONLY run generator OUTDOORS and away from building air intakes. NEVER run generator inside homes, garages, sheds, or other semi-enclosed spaces. These spaces

Summary of Important Safety Information for Operation (cont'd)

can trap poisonous gases, EVEN if you run a fan or open windows. Carbon monoxide is given off whether you are using gasoline, natural gas, or propane to power the generator.

- **No vehicle/marine use.** This generator is NOT designed or approved for use in vehicles or marine applications. Never run the generator inside RVs or other vehicles, on boats, or on pick-up truck beds.
- **Cooling ventilation.** The generator needs adequate, unobstructed flow of air to allow for proper cooling of engine and generator head. Situate so there is adequate clearance around generator to allow for cooling airflow. DO NOT allow debris to accumulate and block airflow.
- **Grounding.** Always ensure generator is properly grounded to prevent electrical shock. This generator is equipped with a grounding post. Always complete the grounding path from the generator to a copper pipe/rod driven into moist earth to a sufficient depth. Check with an electrician for local grounding requirements. If a licensed electrician installs the generator with a connection to your building's electrical circuit for use as a standby power system, grounding will be complete through the building's grounding system.
- **Isolate connection to building's electrical circuit.** Never plug the generator directly into a wall outlet. ANY connection to a building's electrical system MUST ISOLATE THE GENERATOR FROM UTILITY POWER via an UL-listed transfer switch installed by a licensed electrician in compliance with all applicable local building and electrical codes. If the generator is not isolated from the utility power system by such means, generator output will back feed into the utility power grid. This may result in injury or death to utility power workers or others who contact the lines during a power outage. It may also cause the generator to explode or cause fires when utility power is restored.
- **Wet conditions.** Water conducts electricity. DO NOT operate generator where it is wet. Operate on a dry surface under an open, canopy-like structure.
- **CO alarms.** Ensure that working, battery-operated or battery back-up carbon monoxide alarms are used in any dwelling/structure that is in close proximity to the running generator.
- **Hot exhaust - fires.** Exhaust from engine can be extremely hot and cause fire. Position muffler at least 7 feet from combustible objects during operation.
- **Spark arrester.** Equip engine with a spark arrester if generator will be used near any ignitable forest, brush, or grassy land. See the Specifications section of this manual to determine if your generator is already equipped. Make sure you comply with applicable local, state, and federal codes.
- **Fire extinguisher.** Keep a fire extinguisher rated "ABC" by the National Fire Protection Association nearby. Keep it properly charged and be familiar with its use.

Safety – Before Use

Know How to Operate

- **Review safety rules.** Before each use of this generator, review the Rules for Safe Operation section. Failure to follow these rules may result in serious injury or death.
- **Know how to operate.** Be thoroughly familiar with all controls and with the proper use of the equipment. Know how to stop the generator quickly if needed.

Personal Protective Equipment

- **Hearing protection.** The use of ear plugs or other hearing protection device is recommended for those in close proximity to the generator while it is operating.
- **Loose / dangling.** Loose or dangling apparel can become entangled in moving parts. Metal jewelry can conduct electricity. Never wear jewelry or loose-fitting clothing when operating the generator.

Gasoline Safety

Gasoline is highly flammable and explosive. You can be burned or seriously injured when handling fuel. Use extreme care when handling:

- **Fuel outdoors.** Fill fuel tank outdoors – never indoors. Gasoline vapors can ignite if they collect inside an enclosure. Explosion can result.
- **Use approved container.** Never pump fuel directly into engine at gas station. Static charge can build and ignite fuel. Use an UL approved fuel container to transfer gas to the engine.
- **Running / hot engine.** A running engine is hot enough to ignite fuel. Never add fuel or remove gas cap if engine is running or still hot. Stop the engine and allow to cool at least two minutes before adding fuel.
- **Heat / flames / sparks.** Stay away from sources of heat, flame, or sparks while adding fuel.

Summary of Important Safety Information for Operation (cont'd)

- **Don't overfill.** DO NOT overfill the gas tank. Allow at least 1/2 inch of empty space below the fill neck to allow for fuel expansion.
- **Replace cap.** Replace gas cap securely before starting engine.
- **Spills.** Clean up fuel spills immediately. Move generator away from spilled fuel on the ground. Wipe fuel off engine and wait 5 minutes for excess fuel to evaporate before starting engine. Gas soaked rags should be disposed of properly.
- **On skin / clothes.** If gasoline is spilled on your skin or clothes, change clothes and wash skin immediately.
- **Inspect fuel system.** Check fuel system on a regular basis. Look for signs of leaks, deterioration, chafed or spongy fuel hose, loose or missing fuel hose clamps, damaged fuel tank, or a defective fuel switch. DO NOT start generator until needed repairs have been completed.
- **Gasoline storage.** Store gasoline in a cool, dry place in a UL-listed, tightly sealed container.

Safety – During Use

- **Safety equipment / controls.** Always operate the generator with all safety covers, guards, and barriers in place and in good working order, and all controls properly adjusted for safe operation.
- **Know how to stop.** Be thoroughly familiar with proper use of the equipment and all generator controls, output receptacles, and connections. Know how to stop the generator quickly if needed.
- **Damaged.** DO NOT operate the generator with damaged, missing, or broken parts.
- **Carbon monoxide exhaust.** The running engine gives off carbon monoxide, a poisonous gas that can kill you. You CANNOT smell it, see it, or taste it. If you start to feel sick, dizzy, or weak while using the generator, shut off the engine and get to fresh air RIGHT AWAY. See a doctor. You may have carbon monoxide poisoning.
- **Smoking/sparks.** Never smoke near the running generator, and never operate near sources of sparks or flames.
- **Check output voltage.** Check output voltage to ensure the generator is working properly before connecting loads to the generator. Failure to do so could result in damage to equipment powered by the generator and possible injury to the individual. DO NOT adjust output speed of engine to change voltage. If voltage is not within specified range, have generator repaired by factory-authorized personnel.
- **Stabilize before connecting loads.** Start generator and let engine stabilize before connecting electrical loads.
- **DO NOT overload.** DO NOT overload the generator. Make sure that combined starting and running loads do not exceed rated capacity of generator or damage will result.
- **Protect sensitive electronics.** Some electronic equipment, such as computers and audio/video equipment, can be damaged by small fluctuations in the flow of power. Use a surge suppressor for any voltage-sensitive electronic equipment you will be powering with the generator.
- **Wet conditions.** DO NOT operate the generator or handle any electrical equipment while standing in water, while barefoot, while hands are wet or while in the rain or snow; electric shock may result.
- **Ground fault circuit interrupter.** Always use a ground fault circuit interrupter (GFCI) protected extension cord (or outlet, if generator is equipped) in damp or highly electrical conductive areas and on construction jobsites to prevent electrical shock.
- **Electrical cords.** Use only UL-listed, outdoor-rated, three-prong extension cords of the proper size. All extension and appliance cords must be in good condition and not worn, bare, frayed, or otherwise damaged. Use of inadequate or damaged electric cords can cause electric shock or fire.
- **Avoid contact.** Avoid contact with bare wires, terminals, connections, etc., while the unit is running.
- **Electric shock accident.** If an electric shock accident occurs, immediately shut down the source of electrical power. If this is not possible, attempt to free the victim from the live conductor. Avoid direct contact with victim. Use a nonconducting implement, such as a dry rope or board, to free the victim from the live conductor. Apply first aid and get immediate medical help.
- **Hot muffler.** Never touch hot muffler, hot exhaust manifold, or engine cooling fins. Exhaust and engine parts can be very hot and will burn you.
- **Moving parts.** Keep hands, feet, and apparel away from drive belts, fans, and other moving parts. Never remove any drive belt or fan guard while the unit is operating.
- **Refueling.** DO NOT refuel the engine until it has cooled at least two minutes.
- **Malfunction during operation.** Immediately turn off the generator if any of the following conditions arise during operation:
 - Excessive change in engine speed, slow or fast
 - Overheating in load connecting devices
 - Sparking or arcs from generator
 - Loss of electrical output
 - Receptacle damage

Summary of Important Safety Information for Operation (cont'd)

- Engine misfire
- Excessive vibration
- Flame or smoke
- Abnormal noise
- **Adjusting / repairing.** Always turn off generator and remove spark plug(s) or spark plug wire(s) before working on the generator to prevent accidental starting.

Safety – After use

- **Cool engine before storing.** Let engine cool for at least five minutes before storing. A hot engine can be a fire hazard.
- **Shut off fuel supply.** Make sure fuel switch is in the OFF position.
- **Prevent accidental starting.** When generator is not in use, remove key from starter (key start engines) and secure in a safe location, or remove spark plug(s) in order to ensure that generator cannot be started in a storage location or by untrained persons.
- **Storage location.** Store the generator in a dry location away from sources of heat, open flames, sparks or pilot lights – such as water heaters, space heaters, furnaces, clothes dryers, or other gas appliances – EVEN IF the generator's gas tank is empty; residual gasoline could ignite.
- **Exercise regularly.** Exercise generator every four weeks to dry out moisture that accumulates in the windings. If generator cannot be exercised on a regular basis, prepare generator for long term storage.
- **Periodic maintenance.** Perform periodic maintenance as directed in this manual to keep the generator in safe working condition.

Safety - Inspection/Maintenance

Inspect and maintain your generator on a regular basis and repair as needed to keep it in safe working condition:

- **Turn off generator.** Always turn off generator and remove spark plug(s) or spark plug wire(s) before working on the engine or generator to prevent accidental starting.
- **Replace guards / shields.** Make sure all guards and shields are replaced after servicing the generator.
- **Replacement parts.** If a part needs replacement, only use parts that meet the manufacturer's specifications. Replacement parts that do not meet specifications may result in a safety hazard or poor operation of the generator and will void the warranty.

Engine

⚠ WARNING

BEFORE operating the engine, be sure to read this section of the manual, otherwise injury to personnel or damage to equipment may occur.

Engine control panel components

1. Fuel Switch
When the fuel switch is in the ON position, fuel is allowed to flow from the fuel tank to the carburetor. Be sure to return the fuel switch to the OFF position after stopping the engine.
2. Choke Knob
The choke knob is used to provide an enriched fuel mixture when starting a cold engine. The choke can be opened and closed by manually pushing and pulling the choke knob. To start a cold engine, pull the choke knob out to the CHOKE (closed) position to enrich the mixture for cold starting. Once the engine is warm push in the choke knob to the RUN (open) position. To restart a warm engine, leave the choke knob in the RUN (open) position.
3. Engine Switch
Turn the engine switch to the START position, and hold it there until the engine starts. If it starts the engine switch will be in the ON position. If the engine fails to start within 5 seconds, release the engine switch and wait at least 10 seconds before trying to start again. To stop the engine, t

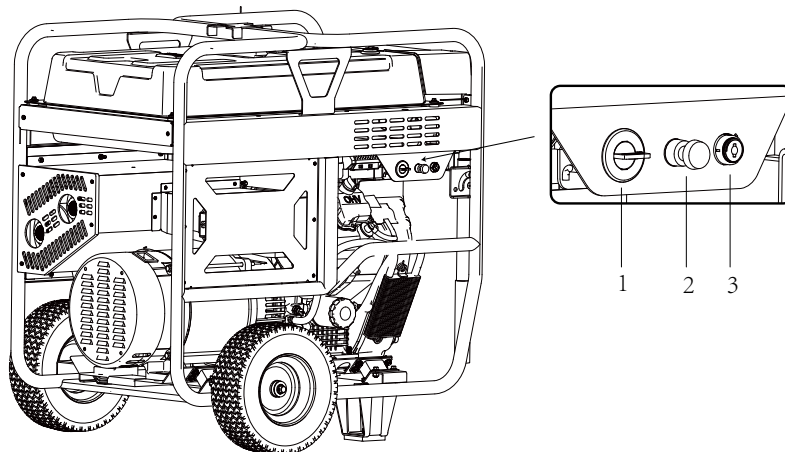

Displacement (cc)	999
Starting Type	Electric Start
Ignition Type	Transistorized Magneto Ignition
Lubricating Type	Pressure Lubricated
Model	999cc
Spark Plug Type	F6RTC
Spark Plug Gap	0.6mm-0.8mm (0.023-0.031in)
Spark Plug Torque	20-25 N m
Intake Valve Clearance	0.10-0.15mm (0.003-0.005in)
Exhaust Valve Clearance	0.15-0.20mm (0.005-0.007in)

⚠ WARNING: Improper maintenance or failure to correct a problem before operation can cause a malfunction in which you can be seriously hurt or killed. ALWAYS follow the inspection and maintenance recommendations and schedules in this manual.

Engine (continued)

Maintenance schedule	REGULAR SERVICE PERIOD	Before each use	Every 3 months or 25 Hrs. (2)	Every 6 months or 50 Hrs. (2)	Every year or 100 Hrs. (2)	Every year or 200 Hrs. (2)	
	Engine oil	Check level	○				
		Change		○			
	Air filter (3)	Check	○				
		Clean		○			
		Replace				○	
	Spark plug	Check-adjust			○		
		Replace				○	
	Spark arrester (1)	Clean			○		
	Oil filter	Replace				○	
	Idle speed	Check-adjust			○		
	Valve clearance	Check-adjust			○		
	Low permeability oil tube (1)	Check	Every 2 years (Replace if necessary) (4)				
	Oil tube	Check	Every 2 years (Replace if necessary) (4)				
	Fuel tank and filter	Clean	Every 2 years (Clean and replace if necessary) (4)				
	Fuel hose	Check	Every 2 years (Replace if necessary) (4)				
	<ol style="list-style-type: none"> 1. Applicable types. 2. Before and after each season. 3. Service more frequently under severe dusty, dirty conditions. 4. These items should be serviced by an authorized generator service center, unless the owner has the proper tools and is mechanically proficient. 						
Engine oil recommendations	<p>⚠ CAUTION: The generator has been shipped WITHOUT oil. Any attempt to start generator without oil may result in engine damage and failure.</p> <ul style="list-style-type: none"> Engine oil is a key factor in deciding the engine's performance. DO NOT use engine oil with additives or 2-stroke gasoline oil, as they do not lubricate properly, which may shorten the engine's service life. Check the engine oil level with the generator stopped on a level ground. Due to viscosity variances with regions and temperatures select the correct type of oil using the chart below. <p style="text-align: center;">Engine oil recommended: SAE10W-30</p> <div style="text-align: center;"> <p>The chart shows three oil grades: 5W-30 (recommended for temperatures from -30°F to 40°F), 10W-30 (recommended for temperatures from 0°F to 80°F), and 30 (recommended for temperatures from 60°F to 100°F). The x-axis is labeled 'TEMP' and 'AMBIENT TEMPERATURE' with scales in both Fahrenheit and Celsius.</p> </div>						

Engine (continued)

Oil draining, oil filling and checking oil level

⚠ WARNING: Never open oil port while generator is running. Hot oil can spray over face and body.

1. Operate the generator for 3 to 5 minutes to thin engine oil for easier draining.
2. Ensure that the engine is stopped and on a level surface.
3. Remove the drain bolt and washer; drain the engine oil into an approved container.
4. Reinstall washer and drain bolt.
5. Remove the oil level dipstick and clean it.

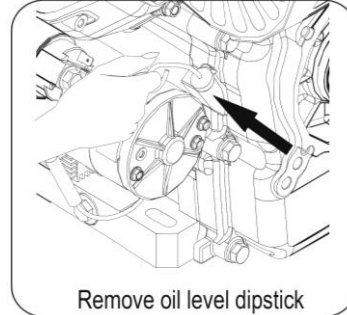
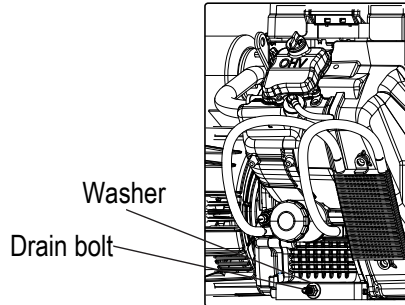

6. Remove the oil filler cap from the oil filler neck.
7. Fill crankcase at oil filler neck with recommended oil quantity.
8. Reinsert the dipstick. Rest on tube neck, remove dipstick, and check oil level is to the upper limit mark on the oil level dipstick. If the oil level is too low, add engine oil.
9. Reinstall the oil level dipstick and oil filler cap securely.

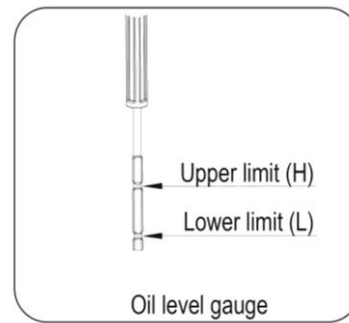
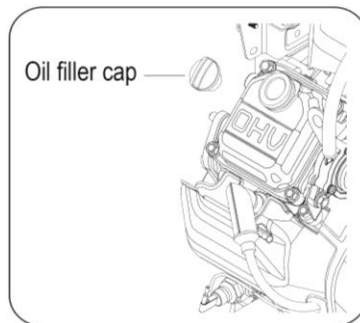

Oil filter replacement

⚠ WARNING: Hot oil can spray over face and body.

First follow the oil draining steps 1 through 4 in the previous section then proceed:

1. Remove the oil filter and pour used oil into an approved container. Dispose of the used oil and oil filter in the appropriate manner.
2. Clean the existing oil filter base.
3. Lubricate the seal on the new oil filter with new engine oil.
4. Thread on the new oil filter by hand until the seal contacts the filter base, then use an oil filter sleeve tool to tighten the filter to 13 N m – 15.N m.
5. Refill the crankcase with the recommended amount of oil found in the specifications section of this manual. Reinstall the oil filler cap and the oil level dipstick.
6. Start the engine and check for leaks.
7. Stop the engine and check the oil level as instructed in step 8 in the previous section. If needed, add oil to bring the oil level to the upper limit (H) mark on the oil level dipstick.

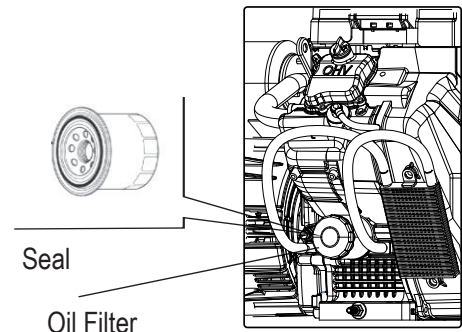

Engine (continued)

Spark plug removal, cleaning and replacement

⚠ WARNING: Be careful not to touch the muffler during or just after the engine has been running.

Proper spark plug clearance ensures the engine's normal running.

- a) Remove the spark plug cap.
- b) Remove the spark plug using the supplied spark plug wrench.
- c) Inspect the spark plug. Remove any carbon deposits and clean the spark plug with a steel brush. If the insulator is damaged, replace the spark plug.
- d) Measure the spark plug gap with a feeler. The gap/clearance should be 0.6mm-0.8mm. If adjustment is necessary, bend the side electrode carefully.
- e) Check if the spark plug gasket is in good conditions and, if not, replace with a new one. Reinstall the spark plug first by hand and then tighten it up by a spark plug wrench. If a new spark plug is used, twist a half turn after impacting the gasket. If reinstalling the original, just twist 1/8-1/4 of a turn.

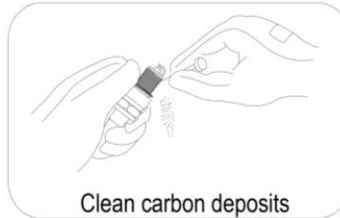
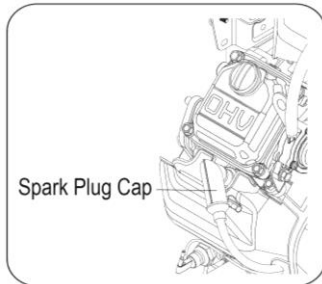

Clean air filter

⚠ WARNING: Never run the generator without the air filter. Rapid engine wear will result.

1. Unhook the retaining clips (6) located on the air filter cover (2).
2. Remove the air filter cover (2).
3. Slide the coarse paper filter element (3) and the fine paper filter element (4) away from the air filter body (5).
4. Clean both paper filter elements by gently tapping the filter elements several times. DO NOT clean the paper filter elements with water, brushes, pressurized air, solvents, etc.
5. Reinsert the fine paper filter element (4) first and then the coarse paper filter element (3) into the air filter body (5).
6. Reinstall the air filter cover (2) with the vent valve (1) facing down like shown below.
7. Secure the air filter cover (2) using the retaining clips (6).

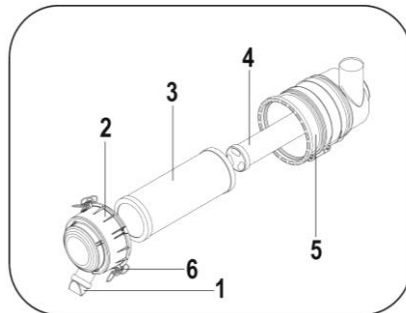

Note: Do not use pressurized air or solvents to clean the filter. Pressurized air can damage the filter and solvents will dissolve the filter.

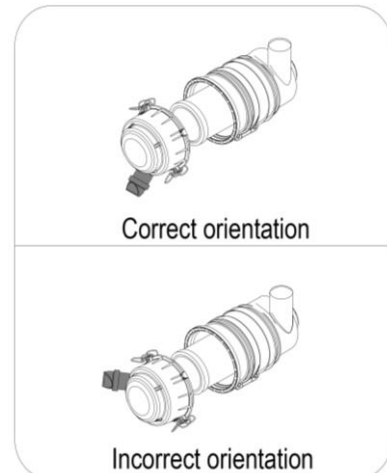

Engine (continued)

Spark arresters

⚠ WARNING: Be careful not to touch the muffler during or just after the engine has been running.

Allow the engine to cool completely before servicing the spark arresters.

1. To access the spark arresters, loosen the 4 bolts and remove the rear muffler hood/cover.
2. Remove the screw that retains the end of the spark arrester screen to the muffler pipe.
3. Remove the spark arrester screen from the muffler pipe.
4. Carefully remove any carbon deposits from the spark arrester screen with a wire brush. Replace the spark arrester screen if it is damaged or cannot be cleaned.
5. Reinstall the spark arrester screen into the muffler pipe and reattached the screw.
6. Repeat steps 2 through 5 on the remaining spark arrester.
7. Reinstall the rear muffler hood/cover and secure using the 4 bolts.

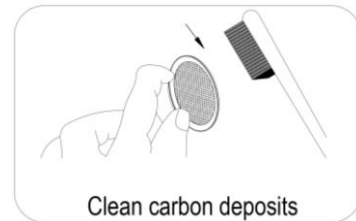
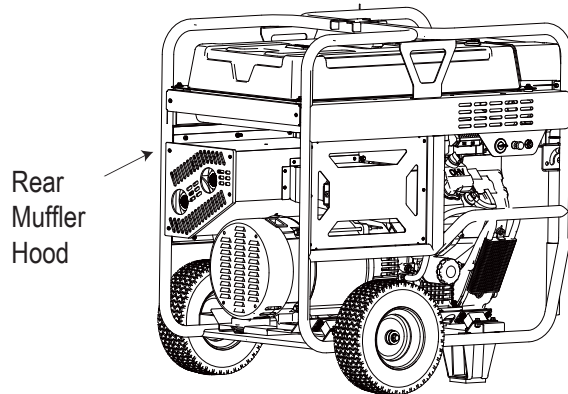

Prepare engine for long term storage if needed

If you will not be able to exercise the generator regularly, you must prepare the engine for long term storage to prevent gum deposits from forming and causing malfunction of the engine.

Prepare engine for long term storage by:

Removing all gasoline from the tank and carburetor.

Draining steps:

1. Position a UL-approved fuel container below the carburetor drain bolt.
2. Turn fuel switch to the OFF position.
3. Remove the drain bolt and gasket.
4. Turn fuel switch to the ON position and drain fuel from carburetor and tank.
5. Reinstall and tighten the drain bolt and gasket.

OR

Adding fuel stabilizer to the gasoline (following manufacturer's instructions).

Fuel stabilizer steps:

1. Ensure gasoline tank is full.
2. Add fuel stabilizer to fuel tank.
3. Run engine at least 10 minutes after adding stabilizer to allow it to enter the fuel system.
4. Shut off engine.
5. Disconnect spark plug wire and remove spark plug using provided spark plug wrench.
6. Add one teaspoon oil through spark plug hole.
7. Place rag over spark plug hole and turn starter to lubricate the combustion chamber.
8. Replace spark plug, but do NOT reconnect the spark plug wire.

Engine (continued)

Removal from storage

⚠ WARNING: Gasoline is highly flammable and explosive, and you can be burned or seriously injured when handling fuel.

Storage time	Service item
Within one month	Use
One-two months	Drain original fuel and refuel.
Two months - one year	Drain original fuel and refuel. Empty and clean the fuel filter. Empty and clean the carburetor bowl.
One year or longer	Drain original fuel and refuel. Empty and clean the fuel filter. Empty and clean the carburetor bowl.

Draining fuel:

1. Turn the fuel switch to the OFF position.
2. Place a UL-approved container below the carburetor; use a funnel to avoid spillage.
3. Remove the carburetor drain bolt and gasket.
4. Turn the fuel switch to the ON position to drain fuel into a UL-approved container.
5. Reinstall and tighten the drain bolt and gasket.

Engine model name and serial number location

The EPA requires that a (DOM) date of manufacture, shown as month and year, is marked on the engine for emissions verification purposes. Please see the below image for the location of the serial on the engine crankcase along with a serial number naming convention table that will help decipher the DOM for the generator.

Engine Model and Serial Number Location

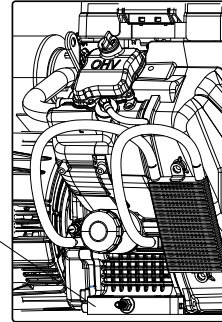

GB1000	Model Name
(1810172A0007)	Serial Number (YYMMDDSSSSSS)
	YY: 18=2018
	MM: 10=October
	DD: 17=17th of October
	SSSSSS: 2A0007 = SN of that engine

High altitude operation

NOTICE: Operating this generator at an altitude greater than 8200 feet (2500 meters) may affect your engines performance, fuel consumption, and emissions. This unit is equipped with a carburetor jet that is sized to allow correct air/fuel mixture up to 8200 feet. However, high-altitude operation is typically between 2000 feet to 7000 feet so you may experience additional decreases in engine performance along with increases in fuel consumption and emissions when operated above 7000 feet.

6075636 Unit Parts List – REV A.1

Ref#	Part#	Description	Qty
1	PH6075636.1	ENGINE ASSEMBLY	1
2	PH6075636.2	SHOCK ABSORBER SUPPORT	4
3	PHAVREG	VOLTAGE REGULATOR	1
4	PH6075636.4	ELECTRIC TAIL COVER	1
5	PH6075636.5	THE BATTERY	1
6	PH6075636.6	WIND DOARD	1
7	**	SCREW	2
8	PH6075636.8	CASTOR	2
9	PH6075636.9	LEG	2
10	PHFOOTSPPT	FOOT SUPPORT DAMPER SEAT	2
11	PH6075636.11	SHORT WIRES	1
12	PHCOTTPIN1	CHECK BACK PIN	4
13	**	TOOTH WASHER Ø8	1
14	PH6075636.14	DAMPER LOCK ASSEMBLY	1
15	**	NUT M8	4
16	**	NUT M8	16
17	**	NUT M8	2
18	PH6075636.18	AIR FILTER HEAT SHIELD	1
19	**	NUT M10*1.25	10
20	**	BOLT M6*25	4
21	**	BOLT M6*12	57
22	**	BOLT M8*16	38
23	**	BOLT M8*30	4
24	**	SPRING WASHERS φ 10	2
25	PHFUELCL12.0	FUEL PIPE CLAMP φ12	4
26	PH6075636.26	FUEL PIPE φ 6.2xφ 12.5x550mm	1
27	PH6075636.27	FUEL PIPE φ 6.2xφ 12.5x550mm	1
28	PH6075636.28	HIGH PRESSURE PIPE	1
29	PH6075636.29	SHAFT	2
30	PH6075636.30	MUFFLER	1
30.1	PH6075636.30.1	SPARK ARRESTOR	2
31	PHSTRIP	GLUE STRIP	4
32	PH6075636.32	MUFFLER MOUNTING BRACKET	2
33	PH6075636.33	MUFFLER HOUSING	1
34	PH6075636.34	REAR MUFFLER HOOD	1
35	PH6075636.35	AIR DUCT WELDING JOINT	1
36	PH6075636.36	PANEL COMPONENT	1
36.1	PH6075636.36.1	THE CIRCUIT BREAKER	1
36.2	PH6075636.36.2	CO INDICATOR	1
36.3	PH6075636.36.3	CO INDICATOR	1
36.4	PH6075636.36.4	TIME ACCUMULATOR	1
36.5	PHBREAKER	THERMAL PROTECTOR	1
36.6	PHTHERMPROTR2	T-TYPE DC SOCKET	1
36.7	PH6075636.36.7	GROUNDING BOLT	1
36.8	PH6075636.36.8	FOUR-HOLE INDUSTRIAL SOCKET	1
36.9	PHTHERMPROTR1	CIRCUIT BREAKER	1
36.1	PHCOIND2	ART FOUR HOLE ANTI-TRIP SOCKET	1
36.11	PHCOIND1	DOUBLE-POLE CUTOFF	1
36.12	PHDIGDIS	THERMAL PROTECTOR	2
36.13	PH6075636.36.13	THREE-HOLE ANTI-TRIP SOCKET	2
36.14	PHDCSOCK	GFCI SOCKET	2
36.15	PHGRDTERM	THERMAL PROTECTOR	2
37	PH6075636.37	ELEC. START SWITCH W/KEYS	1
37.1	PH6075636.37.1	KEY SET (INCLUDES 2 KEYS)	1
38	PH6075636.38	ROTOR BOLT	1
39	PH6075636.39	ROTOR BOLT GASKET 16*32*3	1

Ref#	Part#	Description	Qty
40	PH6075636.40	ROTOR BOLT M10*1.25*255	4
41	PH6075636.41	RACK	1
42	PH6075636.42	THE FUEL TANK	1
42.1	PHFUELFLT	FUEL STRAINER	1
42.2	PH6075636.42.2	FUEL GAUGE	1
43	**	TOOTH WASHER Ø6	1
44	PH6075636.44	AIR DUCT PLATE	1
45	PH6075636.45	DUCT COVER PLATE	1
46	PH6075636.46	BATTERY INSULATOR	1
47	PH6075636.47	PLANKING	1
48	PH6075636.48	ACTIVITY OF BEAM	1
49	PH6075636.49	THE HANDLE	2
50	PH6075636.50	THE BATTERY HOLDER	1
51	PHHNDLRBB	HANDLE A BUMPER	2
52	PH6075636.52	HANDLE MOUNTING BOLT	2
53	PH6075636.53	HANDLE PLUG	2
54	PH6075636.54	THE MOTOR END COVER	1
55	PH6075636.55	THE MOTOR BRACKET	1
56	PH6075636.56	THE MOTOR ASSEMBLY	1
56.1	PH6075636.56.1	CARBON BRUSH	1
56.2	PH6075636.56.2	TERMINAL	1
56.3	PH6075636.56.3	STATOR ASSEMBLY	1
56.4	PH6075636.56.4	ROTOR ASSEMBLY	1
57	PHFUELTKCAP	THE CAP	1
58	PHFUELCOCK1	OIL SWITCH	1
59	PH6075636.59	OIL SWITCH SEAT	1
60	PH6075636.60	DECORATIVE	1
61	PH6075636.61	MOTOR INSULATION	1
62	PH6075636.62	SHORT WIRES	1
63	**	SPRING WASHERS Ø8	4
64	PH6075636.64	PROTECTIVE SLEEVE	1
65	**	BOLT M5*12	7
66	**	SCREW M6*15	1
67	PHVIBISOPAD1	VIBRATION ISOLATION PAD	4
68	PH6075636.68	THERMAL BAFFLE FOR WHEEL	1
69	PH6075636.69	CLIP	2
70	PHFUELOUT	GLIB	1
71	**	BOLT M10*1.25*45	2
72	PHHNDLPIN	PIN	2
73	PHMANCHAY	CHECK VALVE	1
74	PH6075636.74	GASKET, ROTOR BOLT	2
75	PH6075636.75	FUEL TANK INSULATION COTTON	1
76	PH6075636.76	CLIP, WIRE HARNESS	2
77	PHFUELCL7.5	FUEL PIPE CLAMP φ7.5	1
78	PH6075636.78	EXHAUST SEAL WASHER	2
79	PH6075636.79	INTAKE CONNECTOR	1
80	PHCOMODULE2	CO MODULE	1
81	PH6075636.81	OUTLET CONNECTOR	1
82	PHPSIREDVLV	PRESSURE REDUCING VALVE	1
83	PH6075636.83	TWO-WAY CONNECTOR	1
84	PH6075636.84	PRESSURE REDUCING VALVE BRACKET	1
85	PH6075636.85	BATTERY POSITIVE WIRE	1
86	PH6075636.86	BATTERY NEGATIVE WIRE	1
87	PH6075636.87	LOW PRESSURE HOSE	1
88	PHCLCL	CLAMP	3

** Hardware Bag Part # PH6075636.HB Ref #s: 7, 13, 15, 16, 17, 19, 20, 21, 22, 23, 24, 43, 63, 65, 66, 71

PH6075636.1 Engine Parts Explosion - Rev A.1



PH6075636.1 Engine Part List - Rev A.1

Ref#	Part #	Description	Qty
1	Kit # 14	OIL FILTER COVER	1
2	N/A	PISTON	2
3	N/A	PIN, PISTON	2
4	N/A	STEEL BALL	1
5	N/A	OIL PUMP SEALING RING	1
6	Kit # 13	OIL SEAL	1
7	N/A	OIL SEAL	1
8	N/A	CLIP, PISTON	4
9	Kit # 16	GASKET	1
10	Kit # 13	SEALING RING	3
11	N/A	RESPIRATORY TABLETS	1
12	Kit # 14	OIL FILTER	1
13	PH6075636.E13	DIPSTICK	1
14	N/A	POLYURETHANE WIRE MESH	1
15	N/A	POLYURETHANE WIRE MESH	1
16	N/A	POLYURETHANE WIRE MESH	1
17	N/A	ROD ASSEMBLY., CONNECTING	2
18	N/A	OIL PUMP COVER	1
19	N/A	OIL RETURN CHAMBER COVER	1
20	N/A	CRANKCASE	1
21	Kit # 13	COVER CRANKCASE	1
22	Kit # 13	PACKING, CASECOVE	1
23	N/A	SEAL	1
24	Kit # 13	CONNECTING PIPE, OIL FILTER	2
25	Kit # 4	NEGATIVE PRESSURE NOZZLE	1
26	N/A	OIL FILTER	1
27	Kit # 16	FIVE-WAY SUPPORT	1
28	Kit # 16	GUM COVER	1
29	Kit # 16	CLAMP	1
30	N/A	CAMSHAFT ASSEMBLY	1
31	N/A	OIL PUMP ASSY	1
32	PH6075636.E32	OIL PRESSURE SENSOR	1
33	N/A	CHARGING MODULE	1
34	N/A	CHARGING COIL	1
35	Kit # 5	METAL WIRE CLIP	4
36	N/A	CONNECTING PIPE, OIL FILTER	1
37	Kit # 13	CYLINDER HEAD PIN	4
38	N/A	CRANKSHAFT ASSEMBLY	1
39	Kit # 9	START MOTOR ASSEMBLY	1
40	N/A	SCRAPER RING SET, PISTON	2
41	Kit # 6	OIL OUTLET PIPE	1
42	Kit # 6	OIL INLET PIPE	1
43	Kit # 6	OIL CONDENSER	1
44	Kit 6, 7, 16	CLIP, FUEL LINE φ16	10
45	Kit # 14, 16	BOLT M6*12	3
46	N/A	SPRING, PRESSURE RELEASE	1
47	N/A	IGNITION BUSH	1
48	N/A	AMPLIFIER	1
49	N/A	UPPER GUARD	1
50	N/A	LOWER GUARD	1
51	N/A	CYLINDER HEAD	1
52	N/A	CYLINDER HEAD	1
53	N/A	CLIP	5
54	Kit # 15	INTAKE PIPE	1
55	N/A	SPARK PLUG	2
56	N/A	VALVE, EXHAUST	2
57	N/A	VALVE, IN	2
115	Kit # 15	BOLT M8*40	2
116	Kit # 5	FLYWHEEL GASKET	1
117	Kit # 16	BOLT M3*8	4
118	N/A	BOLT M10*1.0*10	1
119	N/A	FLAT PAD	1
120	Kit # 15	BOLT	2
121	Kit # 13	FLAT PAD	4
122	Kit 1, 2, 3, 4, 5, 12,	BOLT M6*22	30
123	Kit # 13	BOLT M8*50	11
124	N/A	BOLT M14*1.5*12	1
125	Kit 4, 8	BOLT M6*30	4
126	N/A	FLAT PAD	2

Ref#	Part #	Description	Qty
58	N/A	SPRING, VALVE	4
59	N/A	ROD, PUSH	4
60	N/A	ROCKER FIXED COLUMN	4
61	PH6075636.E61	ROCKER ASSY	4
62	N/A	VALVE SEAL	4
63	N/A	RINGS	1
64	Kit # 11	RINGS	1
65	N/A	DIPSTICK	2
66	N/A	INTAKE VALVE	4
67	N/A	SEAT, VALVE SPRING, EX	4
68	N/A	LIFTER, VALVE	4
69	N/A	VALVE LOCK CLIP	8
70	N/A	ROTATOR	4
71	N/A	SHROUND	1
72	N/A	SHROUND	1
73	Kit # 1	HEADCOVER	1
74	Kit # 12	HEADCOVER	1
75	N/A	SEAL	2
76	Kit # 15	GASKET	2
77	Kit # 1	PACKING, HEADCOVER	1
78	Kit # 12	PACKING, HEADCOVER	1
79	N/A	PIN, DOWEL	4
80	N/A	FLYWHEEL	1
81	Kit # 5	FAN, RECOIL STARTER	1
82	Kit # 8	IGNITION COIL ASSY	1
83	Kit # 8	IGNITION COIL ASSY	1
84	Kit # 16	LOCK CLIP	2
85	Kit # 7	OIL DRAIN SOLENOID	1
86	Kit # 16	THROTTLE LEVER	1
87	Kit # 16	INSULATOR, CARBURETOR	1
88	Kit # 16	STEPPER MOTOR	1
89	Kit # 4	FUEL PIPE	1
90	Kit # 16	GASKET	2
91	Kit # 4	FILTER	1
92	Kit # 3	GASOLINE PUMP	1
93	Kit # 4	FUEL LINE CLAMP φ12	2
94	Kit # 4, 16	FUEL LINE CLAMP φ11	3
95	Kit # 16	CARBURETOR	1
96	Kit # 10	EXHAUST PIPE	1
97	Kit # 10	CLIP, FUEL LINE φ18.5	2
98	Kit # 4	RUBBER SLEEVE	2
99	Kit # 11	SPEED CONTROLLER	1
100	Kit # 16	LOW PRESSURE PIPE	2
101	Kit # 2	AIR CLEANER ASSEMBLY	1
102	Kit # 16	CONNECTING PIPE	1
103	Kit # 4	PRESSURE TUBE	1
104	Kit # 2	AIR FILTER SEAL	1
105	Kit # 4	WIND SHIELD	1
106	Kit # 7	OIL DRAIN SOLENOID	1
107	Kit # 4	AIR HOOD PANEL	1
108	Kit # 16	CARBON CANISTER PIPE	1
109	N/A	EXHAUST GASKET	2
110	N/A	BOLT M6*43	4
111	Kit # 5	BOLT M12*1.25*35	1
112	Kit # 9	BOLT M8*85	2
113	Kit # 8	BOLT M6*118	2
114	N/A	BOLT M12*1.5*65	10
127	Kit # 16	BOLT M6*95	4
128	N/A	NUT	2
129	Kit # 15	NUT M8	2
130	Kit # 4	NUT M6	2
131	N/A	BOLT, BATTERY	4
132	N/A	BOLT M6*12	3
133	Kit # 6	BOLT M6*18	10
134	N/A	BOLT M6*25	4
135	Kit 4, 5, 11	BOLT M6*16	21
136	Kit # 16	LOW PRESSURE PIPE	1
137	Kit # 16	JOINT	1

PH6075636.1 Engine Kits List - REV A.1

Kit Ref #	Kit Part #	Kit Description	Part Description	Ref #	Part Qty	Kit Qty
Kit # 1	PH6075636.EK1	Valve Cover Kit	HEADCOVER	73	1	1
			PACKING, HEADCOVER	78	1	
			BOLT M6*22	122	5	
Kit # 2	PH6075636.EK2	Air Filter Kit	AIR CLEANER ASSEMBLY	101	1	1
			AIR FILTER SEAL	104	1	
			BOLT M6*22	122	8	
Kit # 3	PH6075636.EK3	Gas Pump Kit	GASOLINE PUMP	92	1	1
			BOLT M6*16	135	2	
Kit # 4	PH6075636.EK4	Recoil Cover Kit	INTAKE PIPE	54	1	1
			GASKET	76	2	
			FUEL PIPE	89	2	
			FILTER	91	1	
			FUEL LINE CLAMP ϕ 12	93	1	
			FUEL LINE CLAMP ϕ 11	94	5	
			TUBING PROTECTION RUBBER SLEEVE	98	2	
			NEGATIVE PRESSURE TUBE	103	1	
			WIND SHIELD	105	1	
			AIR HOOD PANEL	107	1	
			BOLT M8*40	115	2	
			BOLT	120	2	
			BOLT M6*30	125	2	
			NUT M8	129	2	
			NUT M6	130	2	
			BOLT M6*18	133	2	
BOLT M6*16	135	2				
Kit # 5	PH6075636.EK5	Recoil Starter Fan Kit	FAN, RECOIL STARTER	81	1	1
			BOLT M12x1.25x35	111	1	
			FLYWHEEL GASKET	116	1	
			BOLT M6*18	133	4	
Kit # 6	PH6075636.EK6	Oil Condenser Kit	OIL OUTLET PIPE	41	1	1
			OIL INLET PIPE	42	1	
			OIL CONDENSER	43	1	
			CLIP, FUEL LINE ϕ 16	44	4	
			BOLT M6*22	122	2	
Kit # 7	PH6075636.EK7	Oil Drain Solenoid Kit	CLIP, FUEL LINE ϕ 16	44	2	1
			OIL DRAIN SOLENOID	85	1	
			OIL DRAIN SOLENOID	106	1	
Kit # 8	PH6075636.EK8	Ignition Coil Kit	IGNITION COIL ASSY	82	1	1
			IGNITION COIL ASSY	83	1	
			BOLT M6*118	113	2	
			BOLT M6*30	125	2	

PH6075636.1 Engine Kits List - REV A.1

Kit Ref #	Kit Part #	Kit Description	Part Description	Ref #	Part Qty	Kit Qty
Kit # 9	PH6075636.EK9	Starter Motor Kit	START MOTOR ASSEMBLY	39	1	1
			BOLT M8*85	112	2	
Kit # 10	PH6075636.EK10	Exhaust Pipe Kit	EXHAUST PIPE	96	1	1
			CLIP, FUEL LINE ϕ 18.5	97	2	
Kit # 11	PH6075636.EK11	Speed Controller Kit	RINGS	64	1	1
			SHROUND	72	1	
			SPEED CONTROLLER	99	1	
			BOLT M6*18	133	2	
			BOLT M6*16	135	2	
Kit # 12	PH6075636.EK12	Valve Cover Kit, 2	HEADCOVER	74	1	1
			PACKING, HEADCOVER	77	1	
			BOLT M6*22	122	5	
Kit # 13	PH6075636.EK13	Crankcase Cover Kit	OIL SEAL	6	1	1
			GASKET	9	1	
			SEALING RING	10	2	
			COVER CRANKCASE	21	1	
			PACKING, CASECOVE	22	1	
			CONNECTING PIPE, OIL FILTER BASE	24	1	
			CYLINDER HEAD POSITIONING PIN	37	2	
			FLAT PAD	121	1	
BOLT M8*50	123	12				
Kit # 14	PH6075636.EK14	Oil Filter Cover Kit	OIL FILTER COVER	1	1	1
			OIL FILTER	12	1	
			BOLT M6*12	45	2	
Kit # 15	PH6075636.EK15	Intake Pipe Kit	INTAKE PIPE	54	1	1
			GASKET	76	2	
			BOLT M8*40	115	2	
			BOLT	120	2	
			NUT M8	129	2	
Kit # 16	PH6075636.EK16	Carburetor Kit	GASKET	9	1	1
			FIVE-WAY SUPPORT	27	1	
			GUM COVER	28	1	
			CLAMP	29	1	
			CLIP, FUEL LINE ϕ 16	44	4	
			BOLT M6*12	45	2	
			LOCK CLIP	84	2	
			THROTTLE LEVER	86	1	
			INSULATOR, CARBURETOR	87	1	
			"STEPPER MOTOR	88	1	
			GASKET	90	2	
			FUEL LINE CLAMP ϕ 11	94	1	
			CARBURETOR	95	1	
			LOW PRESSURE PIPE	100	1	
			CONNECTING PIPE	102	1	
			CARBON CANISTER AND FUEL TANK	108	1	
			CONNECTING PIPE	117	2	
			BOLT M3*8	122	2	
			BOLT M6*95	127	4	
			LOW PRESSURE PIPE	136	1	
JOINT	137	1				

Limited Warranty

Dear Valued Customer:

The Powerhorse Product you just purchased is built with the finest material and craftsmanship. Use this product properly and enjoy the benefits from its high performance. By purchasing a Powerhorse product, you show a desire for quality and durability. Like all mechanical equipment this unit requires a due amount of care. Treat this unit like the high-quality piece of machinery it is. Neglect and improper handling may impair its performance. Please thoroughly read the instructions and understand the operation before using your product. Always contact Powerhorse Product Support at 1-866-443-2576 prior to having any service or warranty work performed, as some services performed by parties other than Powerhorse approved service centers may void this warranty. This warranty is in lieu of any other warranty expressed or implied and Powerhorse assumes no other responsibility or liability outside that expressed within this warranty.

Limited Warranty

Powerhorse shall warranty any piece of equipment manufactured, or parts of equipment manufactured, to be free from defects in material or workmanship for a period of:

Powerhorse Warranty		
Item #	Consumer Warranty Period	Commercial Warranty Period
99932	2 years from date of purchase by user	90 days from date of purchase by user

"Consumer use" means personal residential household and/or recreational use by a consumer. "Commercial use" means all other uses, including use for commercial, income producing, primary power, off grid power, or rental purposes or when purchased by a business.

This warranty applies to the original purchaser of the equipment (verification of purchase, in the form of a receipt, is the responsibility of the buyer), is non-transferable, and covers parts and labor. Parts will be replaced or repaired at no charge, except when the equipment has failed due to lack of proper maintenance. If a part is no longer available, the part may be replaced with a similar part of equal function. Any misuse, abuse, alteration or improper installation or operations will void warranty. Determining whether a part is to be replaced or repaired is the sole decision of Powerhorse. Powerhorse will not provide for replacement of complete products due to defective parts. Any costs incurred due to replacement or repair of items outside of a Powerhorse approved facility is the responsibility of the buyer and not covered under warranty. Transportation costs to and from service center is the responsibility of the customer.

In addition to the normal warranty, Powerhorse shall warrant any normal wear item from defects in material or workmanship for a period of 90 days from the date of purchase by user. Normal wear items include, but are not limited to, filter elements and electrical brushes.

This warranty specifically excludes the following; failure of parts due to damage caused by accident, fire, flood, windstorm, acts of God, applications not approved by Powerhorse in writing, corrosion caused by chemicals, use of replacement parts which Do not conform to manufacturer's specifications, damage to accessory parts such as starting batteries, damage related to rodent and/or insect infestation and damage caused by vandalism. Additional exclusions: loss of running time, inconvenience, loss of income, or loss of use, including any implied warranty of merchantability of fitness for a specific use. Also, Outdoor Power Equipment needs periodic parts and service to perform well, and this warranty does not cover instances when normal use has exhausted the life of a component or the engine.

This warranty does not cover any personal injury or damage to surrounding property caused by failure of any part. Repair or replacement of parts does not extend the warranty period.

The engine warranty is covered under the same terms and conditions as outlined above. Normal engine maintenance such as spark plugs, air filters, adjustments, fuel system cleaning and obstruction due to build up is not covered by this Powerhorse warranty.

Tel: 1-866-443-2576

Website: www.northerntool.com

Please fill in the following information and have it on hand when you call in on a warranty claim.

Customer Number: _____

Date of Purchase: _____

Powerhorse Serial Number: _____

Item Number: _____

POWER@HORSE™

Distributed by:
Northern Tool & Equipment
Company, Inc.
Burnsville, Minnesota 55306
www.northerntool.com
Made in Vietnam